

# RCA Engineer

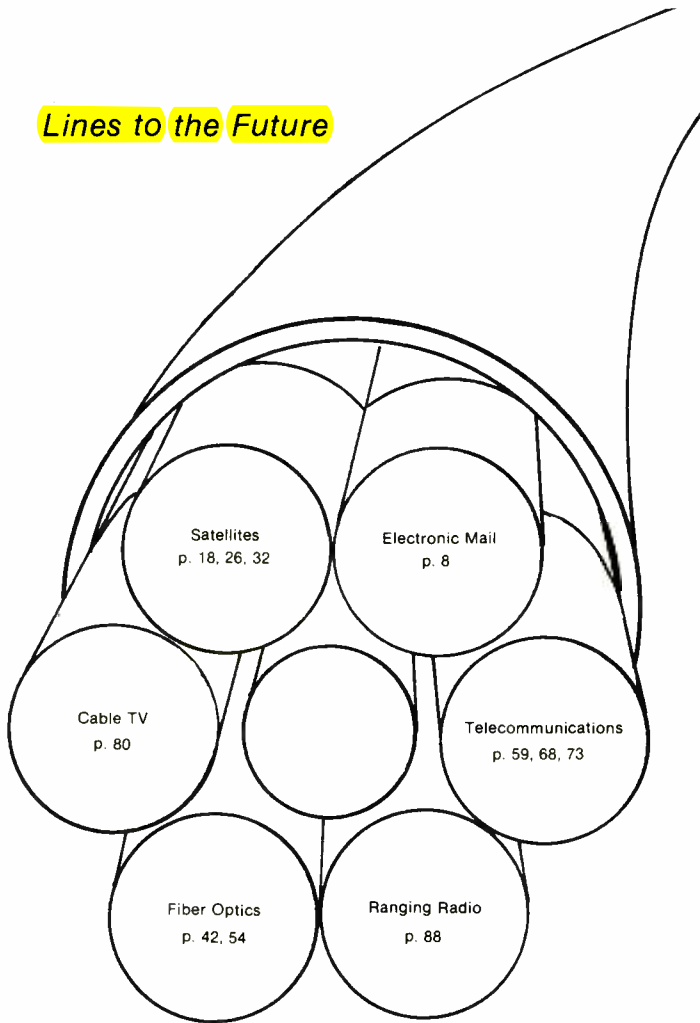
Vol. 26 No. 3 Nov./Dec. 1980



Lines to  
the Future  
•  
Communications  
Trends

Cover illustration by Louise M. Carr

## Lines to the Future



Ancient world mythologies share a common archetype — an awareness that the human bond, the cord of communication, brought us out of inchoate darkness and into the light of knowledge. From clay to papyrus, from print to radio, man has always tried to find better media to carry his language and signals. Advanced communications technologies rest, in essence, on this archetype.

The cable coming out of darkness on our cover carries vivid images of RCA's contribution to advanced communications that RCA authors present in this issue. The cable intimates an exciting world illuminated by fiber-optic technology and spanned by satellite communications. It stands for a world where people are entertained and informed by cable TV. Interconnected by telecommunications and by skillfully integrated electronic/computerized systems like electronic mail. And rescued by digital communications applications of LSI technology such as the digital transponder for survival radios.

These are just some of the communications technologies — our lines to the future — that RCA engineers have created to bring people together, worldwide. We've come a long way from cutting simple hieroglyphs into clay.

--MRS

# RCA Engineer

A technical journal published by  
RCA Research and Engineering  
Bldg. 204-2  
Cherry Hill, NJ 08358  
TACNET: 222-4254 (609-338-4254)

## RCA Engineer Staff

<b>Tom King</b>	Editor
<b>Mike Sweeny</b>	Associate Editor
<b>Louise Carr</b>	Art Editor
<b>Frank Strobl</b>	Contributing Editor
<b>Betty Gutchigian</b>	Composition
<b>Dorothy Berry</b>	Editorial Secretary

## Editorial Advisory Board

<b>Pete Bingham</b>	Division Vice-President, Engineering, Consumer Electronics Division
<b>Jay Brandinger</b>	Division Vice-President, "SelectaVision" VideoDisc Operations
<b>John Christopher</b>	Vice-President, Technical Operations, RCA Americom
<b>Bill Hartzell</b>	Division Vice-President, Engineering, Picture Tube Division
<b>Jim Hepburn</b>	Vice-President, Advanced Programs, RCA Globcom
<b>Hans Jenny</b>	Manager, Engineering Information
<b>Arch Luther</b>	Division Vice-President, Engineering, Commercial Communications Systems Division
<b>Howie Rosenthal</b>	Staff Vice-President, Engineering
<b>Ed Troy</b>	Director, Operations Planning and Support, Solid State Division
<b>Bill Underwood</b>	Director, Engineering Professional Programs
<b>Joe Volpe</b>	Director, Product Operations, Missile and Surface Radar
<b>Bill Webster</b>	Vice-President, Laboratories

## Consulting Editors

<b>Ed Burke</b>	Administrator, Marketing Information and Communications, Government Systems Division
<b>Walt Dennen</b>	Director, Public Affairs, Solid State Division
<b>Charlie Foster</b>	Manager, Systems and Procedures
<b>John Phillips</b>	Manager, Proposals and Publicity, Automated Systems

•To disseminate to RCA engineers technical information of professional value •To publish in an appropriate manner important technical developments at RCA, and the role of the engineer •To serve as a medium of interchange of technical information between various groups at RCA •To create a community of engineering interest within the company by stressing the interrelated nature of all technical contributions •To help publicize engineering achievements in a manner that will promote the interests and reputation of RCA in the engineering field •To provide a convenient means by which the RCA engineer may review his professional work before associates and engineering management •To announce outstanding and unusual achievements of RCA engineers in a manner most likely to enhance their prestige and professional status.

JAN 26 1981



Andrew F. Inglis

## Communications — a service that launched a business

Communications is an appropriate topic for the *RCA Engineer*. It served as a cornerstone of the corporation's original business, and now forms the basis for many other RCA products and services.

Today, we are in the midst of exciting developments in communications technology. And we can take much of the credit for these developments. At RCA, we have an enviable record of matching equipment and services to the needs of the marketplace, and introducing many new communications concepts to businesses of all size and scope.

An example is RCA's work in small, economical communications satellites, where our engineers have made notable contributions to improvements in traffic-carrying capacity and reliability. These contributions include doubling the capacity of a satellite to 24 transponders, introducing solid-state technology to transponder design, and perfecting three-axis stabilized satellites. Together, these engineering achievements have brought the cost of satellite communications down to earth. Now our marketing experts are teaching businesses how to economically use this unique tool.

For instance, the broadcasting advantage of a satellite has been instrumental in the development of the U.S. cable television industry. Within the last five years, the cable industry's growth into 16 million homes has occurred largely because of RCA's engineering and marketing of satellite facilities for cable.

In another case, we have made executives aware that it is the size of their phone bill, not their revenues, that determines their need for satellite service. Today we provide more than 3,000 circuits to private customers and to resale carriers throughout the U.S. We also offer to business a wideband digital data service that is designed and priced for the bulk of today's data communications requirements.

The 1980s present continuing opportunities. Just as RCA's second-generation SATCOM communications satellites will provide more capacity and higher reliability for our customers, work is now underway to investigate even newer and more sophisticated satellites for additional services in the future.

This Communications Trends issue shows that RCA's engineers are immersed in other areas of communications research and applications as well—fiber optics, cable TV, telecommunications and electronic mail.

Andrew F. Inglis  
President  
RCA American Communications, Inc.

# RCA Engineer

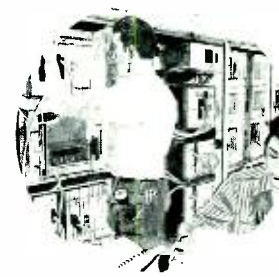
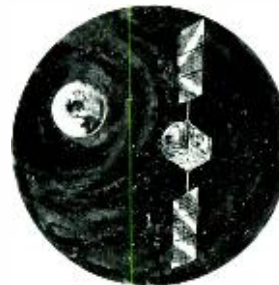
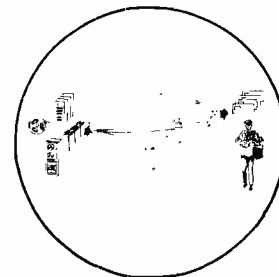
Vol. 26|No. 3 Nov.|Dec. 80

<b>systems</b>	<b>4</b>	Communications — a mild explosion K.H. Powers
	<b>8</b>	Electronic mail for the U.S. Postal Service M.A. Robbins
<b>satellite communications</b>	<b>18</b>	Advanced Satcom: RCA's next-generation domestic satellite system W.H. Braun J.E. Keigler
	<b>26</b>	Data communications via satellite R.A. Langhans T.H. Mitchell
	<b>32</b>	"Two-for-one" microwave system for video S. Yablonski R.J. Klensch
<b>fiber-optic technologies</b>	<b>42</b>	Fiber optical communications: concepts, components and systems G.H. Oisen D.J. Channin M. Ettenberg
	<b>54</b>	Fiber-optic-cable data network D. Deutscher M.R. Mann B.E. Patrusky J.B. Sergi
<b>telecommunications</b>	<b>59</b>	Evolutionary factors in telephone terminal technology J.W. Bakas
	<b>68</b>	CISS means worldwide communications F.R. Smoker
	<b>73</b>	Teleconferencing is a telecommunications alternative to travel A.A. Acampora
<b>digital applications</b>	<b>80</b>	Cable television, an overview of technology J. Ovnick R. Hamell B. Arnold K. Angel R. Schoenbeck
	<b>88</b>	High-accuracy ranging over voice radios R.H. Brader
<b>departments</b>	<b>96</b>	Patents
	<b>97</b>	Pen and Podium
	<b>100</b>	News and Highlights

## in this issue...

### Communications Trends

- Kerns Powers gives an overview of various communications technologies examined by traffic types, transmission media, signal forms and economics (p. 4).
- New communications systems include the comprehensive systems approach (see cover art) exemplified by the electronic mail concept (p. 8).
- Authors Walt Braun and John Keigler describe the innovations and decisions that determined the technical description of the next-generation Satcom satellites (see cover art and p. 18).
- RCA Americom is finding that many customers have moved their traditional voice-band data traffic from noisy terrestrial channels to quiet satellite channels via the 56-Plus system (p. 26).
- But the recently developed two-for-one video radio system, applied by RCA Americom and the Laboratories, can ameliorate the congestion problems associated with terrestrial microwave links serving certain earth stations (p. 32).
- Bandwidths of hundreds of gigahertz are possible as light (see cover art) from a laser or a LED becomes the "wave of the future" carrying communications signals along glass fibers (p. 42).
- Fiber-optic technology is militarily secure and can be used in a command and control system (p. 54).
- This section's lead-off article is a comprehensive view of the telephone industry in light of recent engineering and regulatory developments (p. 59).
- Next, you'll find a description of corporate communications at RCA (see cover art and p. 68).
- And teleconferencing can mean successful, instantaneous, face-to-face meetings without travel woes and expense (p. 73).
- Along with its dedication to other current CATV technologies (see cover art), RCA Cablevision is keeping pace with one of the major growth areas in CATV — addressable, digital technology for subscriber devices and system monitoring (p. 80).
- A small digital transponder module — added to a hand-held survival radio (see cover art) — operates in conjunction with a ranging interrogator in search-and-rescue aircraft (p. 88).



## in future issues...

mechanical engineering, human aspects of engineering, computer-aided design and manufacturing, twenty-sixth anniversary issue.

# Communications — a mild explosion

*Subdivide rapidly multiplying communications technology trends by traffic types, signal forms and transmission media — the growth rate adds up (subtracting inflation) to more than twice the 2.1-percent annual growth of the real GNP per capita over the past century in the U.S.*

---

**Abstract:** *The papers in this issue represent a cross-section of the dynamic activities currently going on in the communication segment of RCA's business. This paper briefly updates the status and trends in the communications industry at large.*

---

## Introduction

Over the past decade, the communications industry in the U.S. has continued to grow at a compound annualized growth rate of 9.5 percent. This compares with about 5.5 percent for the U.S. gross national product (GNP). Internationally, the growth rate is somewhat higher as the developing nations of the world rapidly expand their communications investment. As much of this growth, particularly over the past decade, reflects inflation (and to a lesser extent, population growth) a better measure would be the real rate of growth per capita. On this basis, communications has grown over the past century at an annual rate of 5.9 percent, more than twice the 2.1-percent growth of the real GNP per capita.

In 1980, the total revenue from all communications operations, that is, the

telephone, telegraph and other common carriers, the public and private mobile radios, radio and television broadcasting, and cable television, was about \$60 billion. And if we add to that the \$22 billion expended for equipment sales, we have a total expenditure in 1980 of over \$80 billion. This represents \$350 for every man, woman and child in the U.S. — an expenditure of approximately 3 percent of the gross national product. Let us explore now the trend in these communications expenditures.

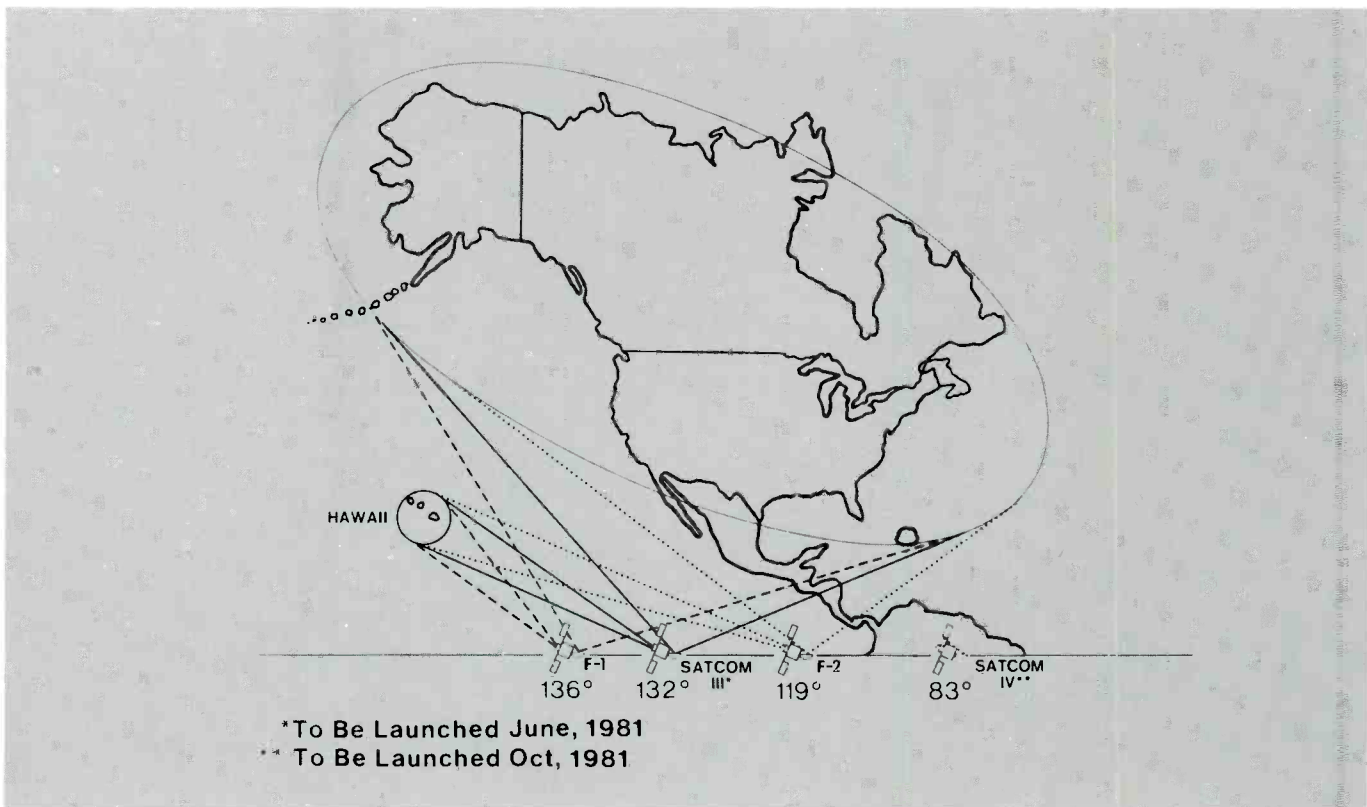
There are three ways by which we may subdivide communications. The first of these is by traffic types, where the major divisions are voice, data and video. The second facet is the signal forms, where we have the many variants of analog and digital signal formats. A third dimension is transmission media. These include wire pairs, coaxial cable, radio, satellite and optical fibers. We shall examine recent trends in communications technology in each of these three dimensions.

## Traffic types

Voice is the overwhelming traffic type on all counts. It dominates the figures in annual revenues, plant investments, equipment sales and number of users. Because of

almost complete saturation of voice transmission, however, the growth rate of this traffic type is now essentially tied to the population growth and to inflation. Its real growth rate per capita is very small. Nevertheless, voice transmission will continue to be the dominant traffic for many years to come and many improvements in the technology will continue to be developed. Of recent significance are the development of echo cancellers for satellite and long-haul circuits, and the use of sophisticated companders that have more than doubled the capacity of FDM/FM links.

Data traffic is historically the oldest traffic type in communications, starting with the telegraph in 1840. But after the invention and development of the telephone, telegraphy was swamped by telephony. Then, shortly before World War II, with the development of the teletypewriter and teleprinter, data traffic experienced a rebirth and over the past several decades Telex and TWX have continued to grow rapidly in both domestic and international services as the lower-cost alternative to the telephone or the fast alternative to the mails. With the development of time-shared computers in the early 1960s, data experienced another rebirth in the communications between computers and terminals and ultimately between com-



**RCA Americom satellite orbital slots.** The capacity of RCA's two unlaunched satellites? Sold-out.

puters themselves. Data traffic has since been the fastest growing traffic type in communications and is now approaching 10 percent of the total market, including traffic revenues, equipment sales and plant investments. A dozen new data carriers and/or packet-switched data services have appeared on the scene in the last few years. Data traffic should continue to grow at its present rapid rate with the introduction of electronic mail services in the next decade.

Although video, in the form of network television distribution, contributes less than one percent of the \$55 billion annual revenue of the telephone industry, video is in second place to voice in total expenditures when one includes radio and television-broadcast and cable-TV systems. In fact, because of the large bandwidth requirement, video requires considerably more capacity than data or voice, one TV channel being roughly equivalent to 1000 voice circuits. In the RCA Americom SATCOM system, video transmission uses approximately half the total capacity. Thanks to the availability of satellites for the low-cost distribution of television entertainment programs, we expect to see the growth rate of video continuing for the next decade—the capacity of RCA's two unlaunched satellites has been essentially sold-out in advance of launch. An even more rapid

growth rate could occur when the cost-effective video teleconferencing is realized. I believe that the video communication business will continue to be larger than data over the next two decades in both revenues and equipment sales. On a worldwide basis, as direct broadcast satellites are introduced, we would expect video to be the major user of satellite communication capacity for many, many years to come.

### Signal format

Historically, again, the earliest form of electrical communication was digital. With the invention of the telephone, however, communication signals became analog and have continued to be predominantly analog to the present day. The major advantage of a digital signal is that it can be regenerated—this permits transmission over many tandem links without the accumulation of noise. Because of this advan-

tage, the digital revolution has been predicted for the past thirty years. Although that revolution has not yet arrived, most engineers still feel that it is coming and the signs are there that digital technology is gradually replacing analog in many transmission systems.

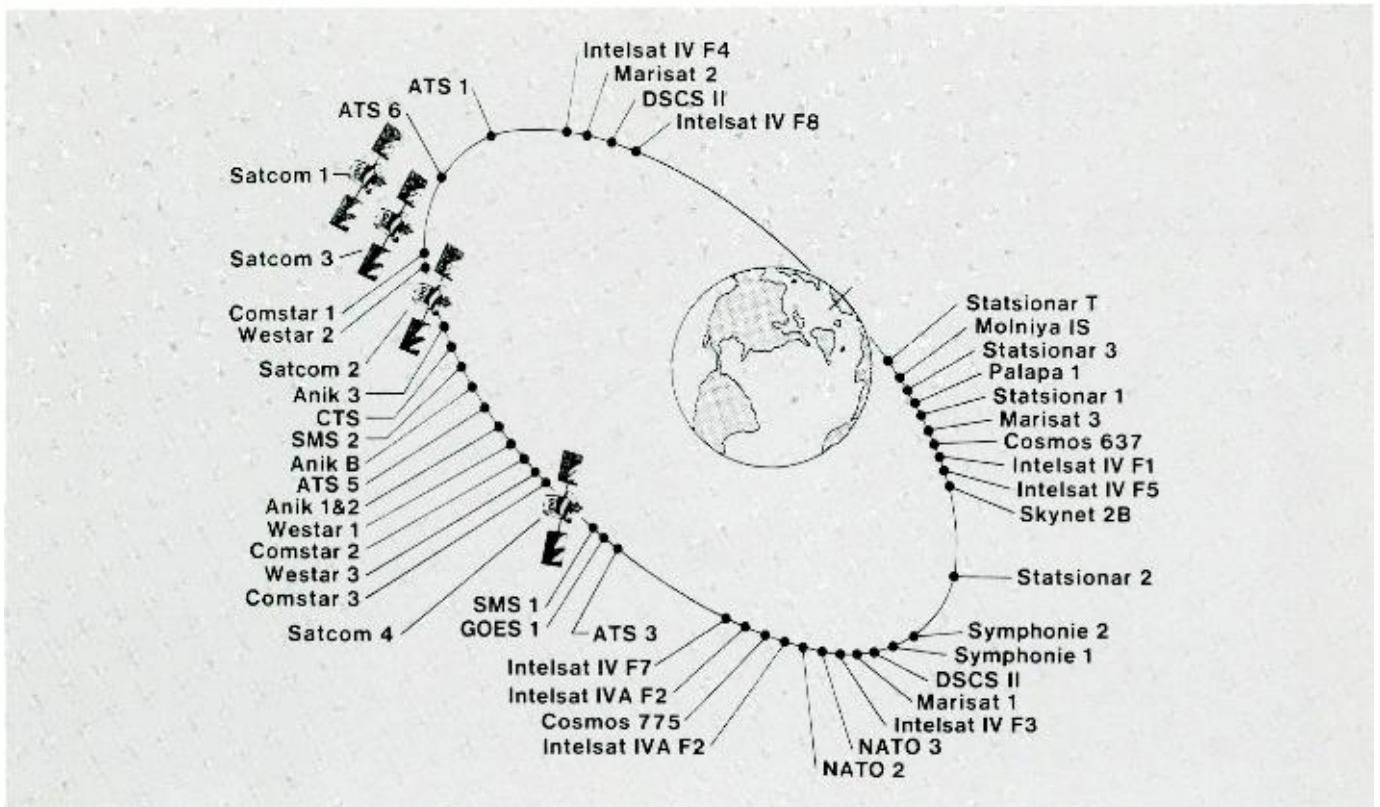
There are two reasons why digital has not yet replaced analog. One of these is that, at baseband, a digital signal requires approximately ten times the bandwidth of its analog equivalent. But one does obtain an advantage from this increased bandwidth in the form of noise immunity. Noise immunity can be achieved by other forms of analog transmission, for example, frequency modulation. For a given signal quality, transmission of either voice or video by digital techniques requires about twice the bandwidth of an equivalent frequency-modulated analog transmission.

A second disadvantage of digital is that the terminal equipment still costs more than with analog. But this disadvantage is vanishing most rapidly. With the develop-

---

**With the development of large-scale integrated circuits, there are clear signs that digital implementation will ultimately be less expensive than analog.**

---



Satellites around the world greatly extend man's capacity for communications.

ment of large-scale integrated circuits, there are clear signs that digital implementation will ultimately be less expensive than analog. Digital techniques have already made great inroads in common-carrier trunk circuits, both cable and microwave radio. This trend will continue because of the better performance and higher stability and reliability of digital technology. Indeed, we are now beginning to see the digital trend in television broadcasting where the digital advantage in multigeneration tape recording is equivalent to that of communication over tandem links. We expect to see over the next two decades a television broadcast plant that has become completely digital, with the signal in digital form all the way from the originating camera, through the television studio and common carrier distribution, to the TV transmitters at the opposite end. That final link from the television transmitter to the TV receivers will be analog for many decades.

Another advantage of digital over analog is its adaptability to encryption or scrambling of the signals. As communication privacy becomes a more important requirement in communication links, we would expect to see digital encryption being widely used. Primarily, for this reason, communications systems for the

military services have been digital for quite some time.

I believe the digital revolution is finally upon us, and that we will gradually see a conversion to digital technology in most communications over the next twenty years.

### Transmission media

Of the \$155 billion book value of the installed base of the U.S. telephone in-

large cities. Much of the growth in investment (which has been averaging \$500 million per year) has been in additional trunk capacity. In recent years, the launching of geostationary satellites has greatly extended the capacity for communications.

In spite of the low cost of satellites expressed in dollars per channel mile, transoceanic submarine cables are still proving cost-effective on the international scene. Since the launching and operation of the INTELSAT series of satellites, more

---

**Fiber-optic technology will ultimately prove to be a valuable asset to communications even though its major application might not yet be visualized.**

---

dustry, most of that investment is for switches in the local distribution that consist primarily of bundles of copper pairs. An additional sizable portion is represented by intercity coaxial cable and microwave relay systems. The newest segments of the installed plant are the satellite systems that interconnect major

than 35 new submarine cables have been installed. Annual investment in these cables is averaging \$250 to \$300 million. Over the next five years it is expected that at least seven new cables will be laid, including the large TAT-7, with the North Atlantic cable carrying 4200 channels of the capacity.



The INTELSAT system now consists of 12 satellites in orbit serving a worldwide network of over 200 earth stations in 150 countries. In the U.S. alone, there are an additional eight domestic satellites being used, and worldwide there are currently over 400 earth stations used for domestic purposes. This of course does not include the over 3500 receive-only earth stations serving the cable TV industry in the U.S. With the opening of new frequencies in the 12- to 14-GHz band, one can expect satellite communications to continue to grow at a rapid rate to at least three times the capacity of the existing 4- to 6-GHz system.

The role of fiber optics in telephone trunking seems assured, especially for intracity trunks and intercity underground installations. The new single-mode fibers operating at the longer wavelength of 1.3 microns will permit fiber optics to be used in the very-long-haul transmission links because dispersion in these fibers is so low that repeaters need only be spaced some 30 kilometers apart. Their use in other applications is not yet a clear picture. A number of cable-TV installations use fiber optics as supertrunks, but the very large capacity potential is not yet fully used anywhere. I would expect a major application in the future to be in local distribution of multichannel video. Another application will be in the digital television studio where the high bit rate of a single video channel would tax the capacity of coaxial cable. Fiber-optic technology will ultimately prove to be a valuable asset to communications even though its major application might not yet be visualized.

## Conclusion

Communications continues to be a steady yet dynamic worldwide growth business. RCA is well positioned in many segments of the business and is a recognized leader in the development and application of the critical technologies. RCA engineers should be proud to be involved in this thing I have called "a mild explosion."

**Kerns Powers** joined RCA in 1951. He is now Staff Vice-President, Communications Research, at RCA Laboratories where he is responsible for planning and directing the research in support of Consumer Electronics, Commercial Systems, Government Systems, and the communications businesses of RCA.

Contact him at:  
**RCA Laboratories**  
**Princeton, N.J.**  
**TACNET: 226-2746**



# Electronic mail for the U.S. Postal Service

*A unified systems approach to electronic mail combines several hardware and software technologies in an effort to further improve the effectiveness of the mail service.*

---

**Abstract:** *The author details the concept of a Postal Service electronic mail system, discusses a test and demonstration system recently completed by RCA's Government Communications Systems in conjunction with the U.S. Postal Service and projects a view of the mature system.*

---

Open any professional magazine in telecommunications or data processing, and more likely than not the term "electronic mail" will spring forth from some advertisement or other. The term captures uniquely the concept that the creating and dispatching of old-fashioned paper letters can be streamlined through the miracle of modern electronics. The term serves advertisers well, and it is used to introduce various products and services such as word-processing systems, private satellite links and facsimile networks.

The United States Postal Service has for some time now been investigating its own version of electronic mail. It can lay claims as old as any to the use of this term. RCA Government Communications Systems has supported the Postal Service under contract since 1976 in these investigations, with emphasis on the system as a whole. This article will discuss the concept of a Postal Service electronic mail system, will provide a projection of how it may finally look as a mature system in the future, and will discuss a demonstration system which we recently completed and installed at the

Postal Service Laboratories in Rockville, Maryland. But first, a brief discussion of the operations of the United States Postal Service is in order since it is into these operations that an electronic mail system must fit, and it is from the context of these operations that the Postal Service electronic mail system derives its justification.

By any measure, the United States Postal Service is a major operation. In 1979 the Postal Service handled close to 100-billion pieces of mail. The main part of the volume is due to letter mail, close to 85-billion pieces when both first-class and third-class mail is considered. The 100-billion pieces produced revenues of 16-billion dollars. But in spite of these revenues, expenses have exceeded income in every year from 1945 to present, except for 1979. Most of this expense—86 percent—is due to manpower. The Postal Service employs some 660,000 people, of whom about 193,000 are carriers, 230,000 are clerks and mail handlers, and the balance are in management, maintenance and the inspection services.

Mail operations are carried out through a hierarchical network of facilities. At the bottom of this hierarchy are some 40,000 post offices and branch offices. These are the post offices, with which we are all familiar, that sell stamps and supply other services through the postal lobby window and collect and deliver mail. Less familiar are the approximately 570 Sectional Center Facilities and Area Distribution Centers. Letters, collected for mailing, flow from the post office to the Sectional Center for sorting and redistribution. They may

then also flow onward to the Area Distribution Center—the gateway for out-of-state traffic. But 60 to 70 percent of mail will be delivered into the same Sectional Center area from which it originated. This network currently produces a standard of delivery, typically, in which 95 percent of local mail is delivered the next day, 88 percent on the second day within 600 miles and 89 percent on the third day for cross-country mail.

A good deal of modernization and automation has been introduced into the Postal Service, particularly in the last decade. In a typical Sectional Center one may see cancelling machines, mechanized sack emptiers, and computer-supported sorting machines, some with optical-character-reader (OCR) address-reading. During that same decade, in spite of growing mail volume, gross productivity has increased rather steadily, from about 125,000 mail pieces per man per year in 1971 to about 150,000 in 1979. Further improvements in productivity are expected through the introduction of Read-Sort, an OCR-based address-reading and routing technique, but attempts to further streamline operations may well face diminishing returns.

The introduction of electronic mail into the Postal Service would represent an opportunity to improve the economics of the Postal Service in a major way by providing a new and distinctly more proficient level of automation. It also offers the possibility of greatly improving the speed and consistency of delivery. These considerations will be discussed



**Postal Sectional Centers and Area Distribution Centers contain letter sorting machines.** In these machines, unsorted letters are mechanically moved to a position in front of an operator who keyboards address data. This keyed data causes the letter to be moved to a correct output sort bin. Re-sort at several locations is typical for a letter traversing the country.

further. First, it is desirable to provide a description of the postal electronic mail system as study has projected it to exist at maturity, some decades in the future.

The future is, of course, mercurial and elusive. Any projection of the future must be viewed as simply one of a number of outcomes which can be projected. If study is done well, one may hope that a correct projection has been made. But only the future can test the merit of what is about to be described. For this reason, the Postal Service cannot ratify as a policy position what is described below.

## Electronic mail: the concept of the mature system

Under contract to the Postal Service, RCA Government Communications Systems, with the support of RCA Laboratories and the Advanced Technology Laboratory, has carried out an intensive 30-month study to evaluate, select and recommend a preferred approach to a domestic electronic mail system. It is not our intent to review in detail the extensive territory covered in this study. It is sufficient to say that what was sought was a system-concept approach

which, to the greatest extent possible, was compatible with the inherent internal structure and content of letter mail; in tune with current and emerging trends in letter mail preparation; implementable at minimum technical risk and cost; compatible with the existing collection and delivery system; able to service a high percentage of the total letter-mail volume; capable of producing substantial cost reductions in the mail handled; and able to significantly improve delivery service.

The concept of electronic mail system at maturity which emerged is briefly described below.

**Input Media** — The system will serve those business and individual mailers who are able to supply mail input data on one of the several acceptance media found suitable for this purpose. These will be physically forwarded to the nearest electronic mail station. Foremost among these media is magnetic tape. Today, over 60 percent of first-class mail is computer generated. While today tapes produced in this process go to the printing room of the mailer, the electronic mail system will intercept these tapes before such printing. It will also accept letter data on small magnetic

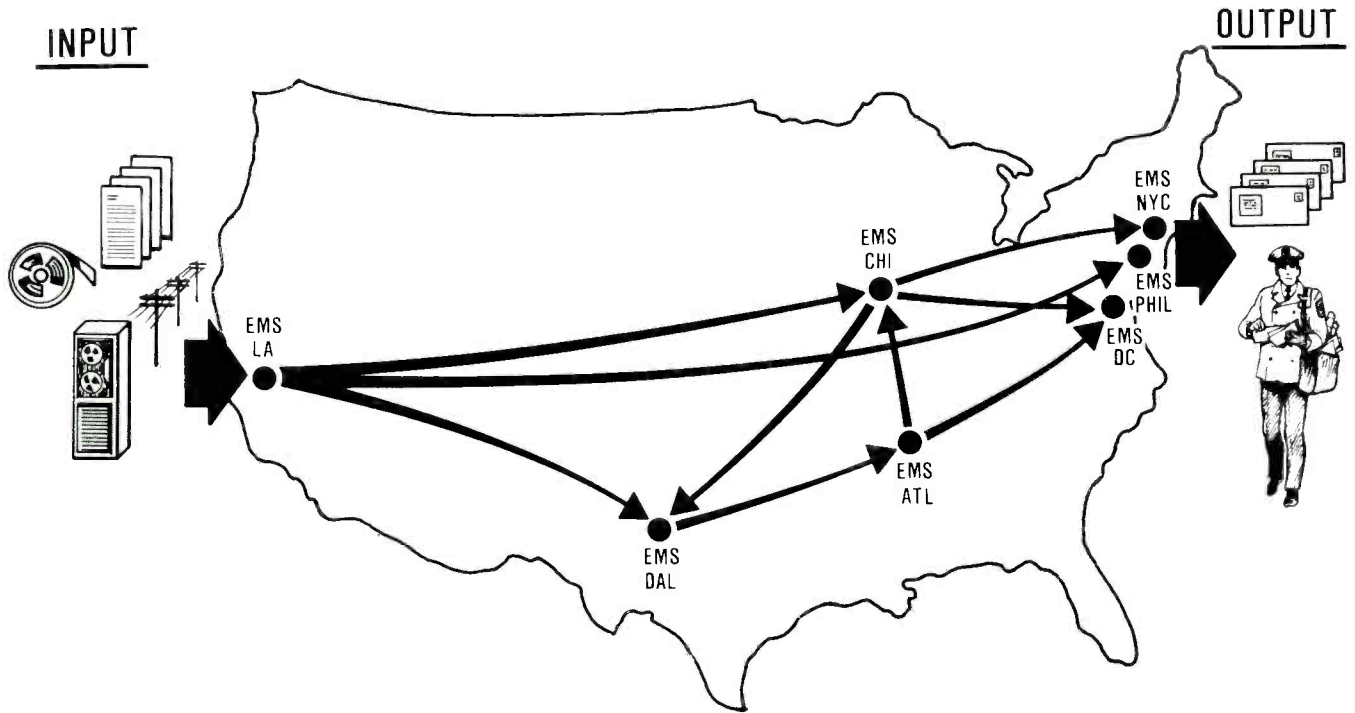
media such as floppy disc or tape cassette, prepared on word processors. And it will accept stacked and packeted paper letter sheets meeting certain preparation standards. At the electronic mail station serving the mailer's location, data on magnetic media are inducted through tape and other reading devices. Stacked paper mail is introduced to a scanner where pages are singulated, the header and address read by optical character reader and text by facsimile.

In contrast to these business bulk multiple mailings, individuals with one or a few letters may enter these into the system via a self-service terminal (Electronic Mail Box) located conveniently in local post offices and other points. This is a ruggedized coin-operated device based on facsimile scanning with keyboard and display for header entry.

The electronic mail system will also accept communication inputs which derive from word processors, office facsimile and possibly other types of terminals. Computer-generated data on tapes may be entered remotely in this manner, but total volume entered by means of communications is not expected to be large, as generally this entry mode is both more expensive and, so far as bulk data on tape is concerned, slower than physical input. Communications for this purpose are obtained by the mailer from an appropriate common carrier.

**Letter Structure** — Letters entered on magnetic media will be predominantly alphanumeric in data content. But, this does not mean that the resulting letter is intended to be merely an alpha message like Telex or Mailgram. Rather, in the electronic mail system, these inputs will result in letters with corporate logos or letterheads; upper and lower case; single or mixed fonts; forms as in bills, invoices and the like; color; and signatures and graphics. Thus, most of the structural content visible in the letter mail of today can be served, albeit with necessary compromises in latitude of choice in these characteristics.

**Volume** — To determine the total mail volume anticipated to be served by the electronic mail system at maturity, the content and volume of some 24 sub-streams of letter mail were examined and factored to that portion which the system could successfully serve in view of capabilities suggested above. In a time frame in which the annual letter mail is



The RCA System Definition study projects a volume of 25-billion pieces per year for the mature electronic mail system. Inputs are on various media: paper, magnetic tape, floppy disk, and by communications. Output is an enveloped multi-sheet letter, postal carrier delivered.

projected as 93-billion pieces, the portion which electronic mail could serve is approximately 50 billion. It was assumed that, at maturity, the system will have succeeded in capturing half of this, or 25-billion pieces per year.

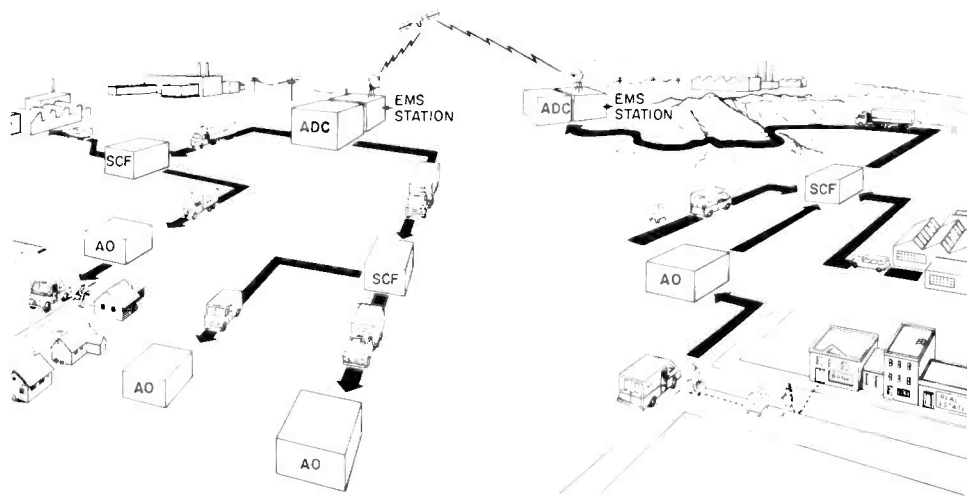
**Output Media**—The output of the system is entirely enveloped paper intended for carrier delivery. Output by electronic means, directly into the homes and offices of recipients has a certain conceptual appeal. But, so far as a postal electronic mail system is concerned, there are formidable obstacles against its realization in a practical way. If hard copy terminals are assumed, problems exist in the terminal cost, consumables support and replenishment and the cost of communicating each message. If the terminal is assumed to be the TV set, problems exist in archiving messages until called for, and no hard copy exists for reference or turnaround. For both assumptions, it should be recognized that the Postal Service delivers to some 70-million delivery points, and that most or all such points would need terminals before the approach could be successful.

In any case, since these conclusions of the study were formulated, it has become accepted Postal Service policy that postal electronic mail will not incorporate electronic output to the recipient.

**Network**—The electronic mail system is implemented through 87 processing

stations distributed around the country. These receive the physical media from mailers in their region, accept communications inputs from mailers and from other stations, and carry out numerous steps of computer processing and printing. The stations communicate directly with one another by means of satellite links implemented by C-band terminals at each station, operating in a time-shared frequency-division-multiple-access (FDMA) mode through

a domestic satellite. These trunk facilities are to be provided by a common carrier. The 87 stations are co-located with Area Distribution Centers and the larger mail volume Sectional Centers. Physical media—tapes, for example—reach the electronic mail station as part of mail movement through the conventional mail network. These media may arrive first at the local post office. These then join the regular dispatch to the Sectional Center and the Area Dis-



Physical media inputs flow up the existing postal network, from Associated Post Office (AO) to Sectional Center Facility (SCF), to the Area Distribution Center (ADC), and thence to the co-located electronic mail center. Printed mail flows back down the network to the letter carrier. Eighty-seven stations, nationally, are expected to achieve 95-percent next-day delivery independent of distance.

tribution Center. From these points, the media are transferred to the electronic mail center. Here, electronic conversion and processing takes place, and mail is printed and enveloped. Mail for other stations is transmitted to those stations where identical processes are carried out. Trays of mail, once printed, are then sent back to the Area Distribution Center and Sectional Center and are then moved in due course to the post office. Here the carrier merges this with conventional mail and then proceeds to his delivery route.

**Processing** — Processing involves message switching, sorting, accounting and statistics-gathering processes, similar in function to processes to be described in further detail when the electronic mail Evaluation and Test System (ETS) is discussed later.

**Printing-Enveloping** — Printing is carried out on high-speed printers operating at four pages per second. These print along a continuous web of plain paper. Letter data is sent from the processor to the printer, sorted to the carrier's walk sequence. This is the letter order the mailman maintains while carrying out deliveries. This means that sequential letters will be different in content and structure, one letter to another, so that batch printing is not feasible. The printer must be capable of this flexibility, must provide the highest visual print quality, and also provide several colors for logos and the like. These various demands are met by use of a multi-stage laser-xerographic printer, with letter composition carried out in a computer. After the web is printed, it moves to the enveloper. In the enveloper, the web is cut into sheets, and a letter of up to five pages is then folded, enveloped and trayed.

**Security** — Security of letter data, address lists, and payment accounts is provided by a combination of design and operational policy. Tapes and other bulked inputs are kept underlock-and-key in transit. User terminals are not allowed an inquiry mode directly to the station processors, and only authorized terminals within the station are allowed access to the computer programs, files and accounts. All such accesses are auditable. All station-side induction equipment, processing equipment and printing-enveloping equipment is confined to a restricted area where only authorized personnel are allowed. Trunk communications channels are protected by encryption.

## Advantages

Clearly the Postal Service would not be interested in electronic mail if it did not offer some extremely attractive advantages.

First, the system will provide next-day delivery for 95 percent of the mail entered by 5 PM on a given day. This is nationwide, independent of distance between sender and recipient. In spite of the time consumed in the movement of physical media — tapes and the like — up the postal network, and of finished letters down the network, analysis indicates that the 87 stations provide sufficient decentralization and dispersion so that the 95-percent next-day criteria will be achieved. In addition to this significant improvement in delivery speed, the system will provide highly consistent delivery so that the mailer may know with confidence on what day his letter will be delivered.

A second advantage lies in the significant improvement in costs which the electronic mail system will offer. Cost analysis for this system was performed by first identifying all significant non-recurring and recurring cost-elements for development, implementation, personnel, consumables and the like, and then attributing and summing costs in constant dollars. The result of this shows that the system will handle letters at a cost of \$20 per thousand letters. A comparison to present costs indicates that this represents a saving of approximately \$30 per thousand letters handled, or three cents per letter. Carrier costs and institutional overhead is not included in this analysis since these are identical in electronic mail and in the present system. Essentially, these improvements result from a high degree of automation provided by this system over the present system. Once letter data is inducted, essentially no further manual handling of the letter is needed until trayed letters are produced at the destination station. In contrast, today, even with the present level of automation, sometimes a half dozen rehandlings of a letter are required as the letter works its way across the country. Since analysis indicates that electronic mail costs are lower than conventional mail costs, it is to be expected that an electronic mail system as described above will stem the rate of cost increase.

Further, because of the data processing basis of the electronic mail system, the Postal Service will be able to count mail accurately, to trace selected letters if the mailer desires, to generate customer accounts automatically, to measure traffic

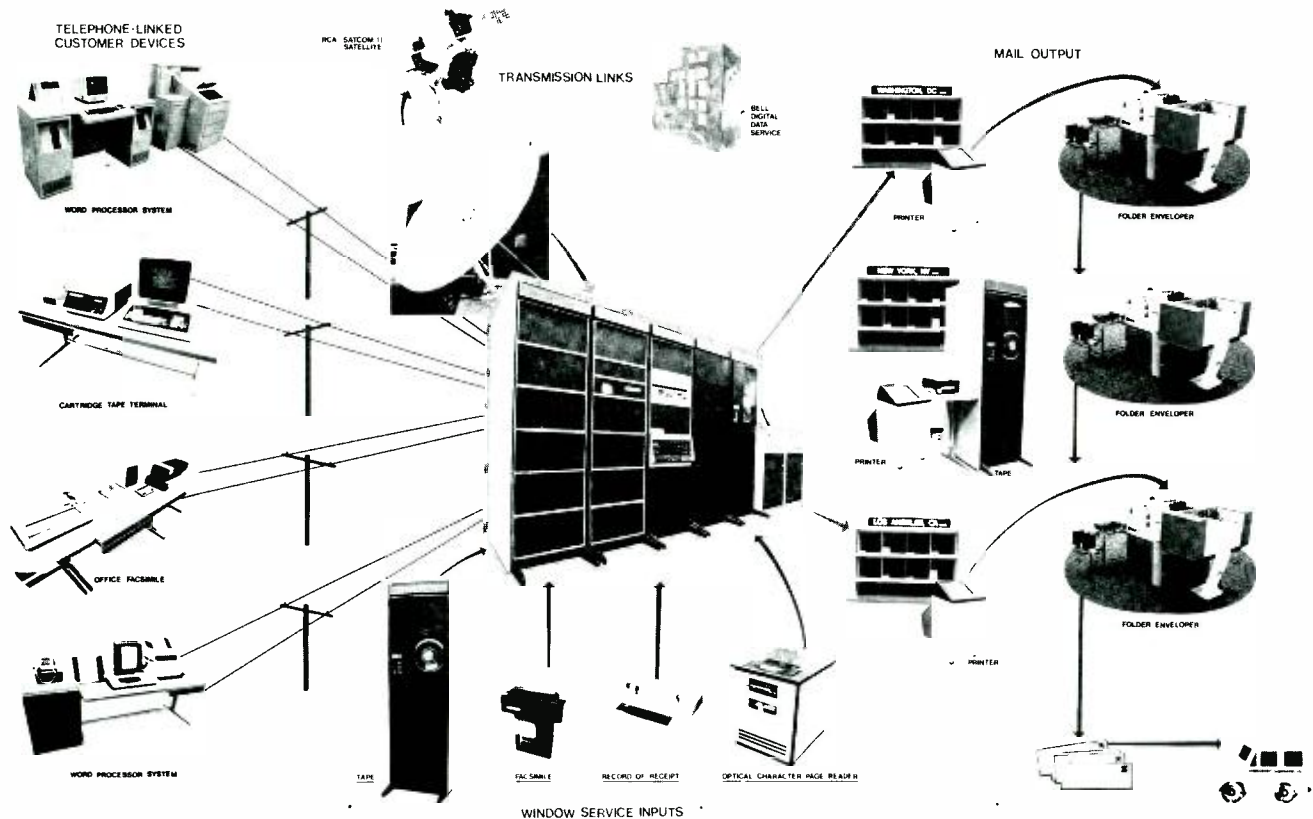
flow, and to detect and correct blockages immediately. Thus, a step forward in manageability of mail operations is anticipated.

Finally, we can also add that it is highly desirable for the Postal Service to be able to deal with the letter-mail data directly in the form in which over 60 percent is now directly originated — in electronic media form. This percentage can be expected to significantly increase as word-processing equipment spreads throughout business and industry. This is the electronic age, and the Postal Service should not be expected to be wedded forever entirely to the same medium used in the time of Ben Franklin, the founder of the postal system in North America.

## Market uncertainty, evolution and growth

The major area of uncertainty in the picture presented above lies in the response of the mailing market to the system. Electronic mail is a revolutionary innovation rather than an incremental change or improvement to an ongoing and well-understood operation. Under these circumstances, it is doubtful that pre-introduction market research can produce a reliable prediction of the market's reaction. Thus, the precise electronic mail services that the users will find most attractive, the letter structures that he will find most useful and the postage rate at which various levels of volume can be achieved — that is, the demand elasticity — are presently unknown. In the absence of valid market research, our electronic mail study was an attempt to understand and to incorporate so far as technically and economically possible, the features, functions, services and the low costs that seem to be important to the mailer.

The correctness of these decisions and the response of the market can really be gauged only when the electronic mail service is offered to the mailing public. Because of present uncertainties in market response, and for a variety of other reasons, the system must start on a relatively small scale. This means that the system should be introduced in the top-market cities initially, at significantly less than full predicted capacity, and with less than all of the services and features called for in the mature system. Concurrently, it is important to have available for market test those features and services still held off-line. By these means, interest in those features and services can be determined. Services,



**The Evaluation and Test System (ETS), developed and shipped in a 12-month span, was based mostly on existing equipments, but high-resolution facsimile, and low-resolution facsimile interfaces to telephone lines were specially developed.** Other input devices were word processors, tape cartridge readers, tape readers and optical character readers (OCR). Output letters are computer-formed to include stored logos, signatures and business forms. Approximately 100,000 in-core instructions were specially developed for the system.

geographic coverage and capacity can then be expanded in accordance with measured need, and in step with demand.

It can now perhaps be seen more clearly why a cautionary note was introduced at the beginning of this mature System-Concept review. Market uncertainties have been mentioned above. In addition, uncertainties exist in future economic trends, and in future policy and regulation. The direction and rate of evolution of a Postal Service electronic mail system will be influenced by these considerations.

While these market acceptance and growth factors were unknown, a number of possible patterns of system expansion and growth were modeled and analyzed during this study contract. The essential variables in these studies were: the timing and pace at which improved service capabilities are brought on-line; the rate of market growth; and the volume at the end of the analysis period. Results indicated for what is considered the probable growth case, an internal rate between 39 percent and 47 percent and a cumulative net present value of about 3-billion dollars, discounting at 10 percent over a 20-year period of system development, implementation and growth.

## The evaluation and test system (ETS)

Early in 1979, the Postal Service awarded a contract to RCA Government Communications Systems to design and implement a system to demonstrate various features and capabilities of the electronic mail concept. The budget was tight and the schedule even tighter. The contract required the shipment and installation of the system at the Postal Service Laboratories at Rockville, Maryland twelve months after the start of the contract.

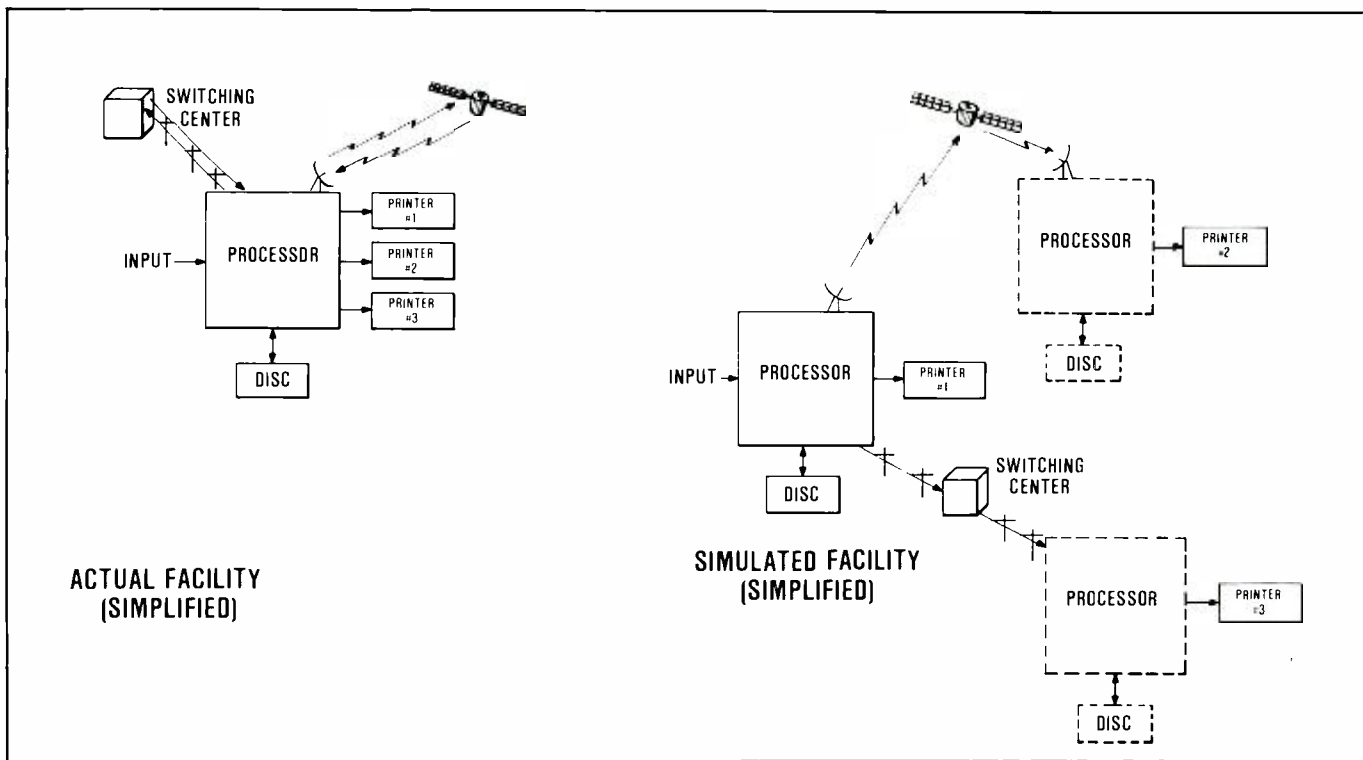
The complexity of the system can be gauged in part from the figure above. This figure shows the "tip of the iceberg" since it cannot illustrate the substantial amount of software required.

To make this delivery schedule possible, several steps were taken. First, and quite important, system requirements, software requirements and the design concept were formulated and documented very early in the program. With the collaboration of the responsible Postal Service personnel, these were agreed upon early, and thereafter a requirement and design freeze was in force.

Hardware development was minimized

and existing equipment was pressed into use to the extent possible. This was centered around the DEC PDP-11/70 and certain of its peripherals. Still, special adaptations had to be made to an envelope, printers and analogue facsimile devices. Also, a high-speed high-resolution digital facsimile, and analogue and digital facsimile interfaces to the computer, needed to be developed for this system.

An orderly program of system development was planned and carried out. Equipment was specified and ordered early and, when received, integrated in our laboratory. Software followed an orderly progression of development through system design, module design, coding, integration and test. Software modules were developed in a logical order per an integration plan prepared for the purpose. This approach permitted the selected hardware devices to be exercised first, then integration into an initial end-to-end system "thread," followed by the incremental addition of other devices and functions. Some 40 software modules and several device drivers needed to be developed for the ETS, many of them quite complex and unique to this need. This software—



While one physical processor was used in the ETS, three separate city locations were simulated. The computer maintained separate files and separate sorts for these cities. Data flow from "this city" is through a domestic satellite or over a Dataphone Digital Service (DDS) line into the "other city" file. Three separate printers support the three "cities."

approximately 100,000 in-core application-program instructions — was developed in about 9 months and the system was shipped on time.

## Description of the ETS

The ETS is a system of input and output equipment, data processing equipment and software, a satellite earth terminal and transponder, a leased digital data line, plus other equipment, integrated into a reduced-scale functional representation of an electronic mail system. In the ETS, three separate electronic mail stations are represented. These simulate electron mail centers at Washington, New York and Los Angeles. For reasons of economy, the ETS is set up to demonstrate mail input functions for only one of the stations — Washington. While the system includes only one processor, it contains distinctive computer files, and carries out distinctive and concurrent communications, sorting, message composition and printing operations for each of the three station locations. To this extent, the processor is acting as if it were the three separate processors to be expected at these three different locations.

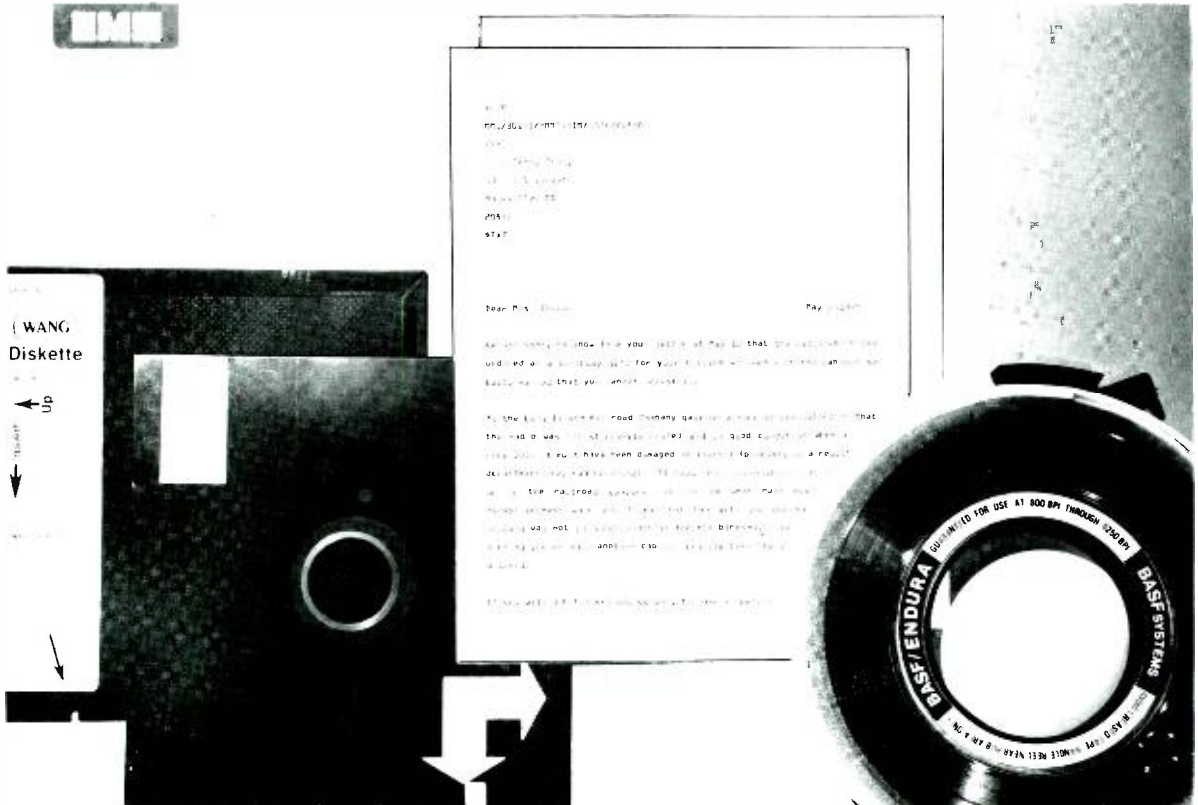
As the system is set up at the Postal

Laboratories at Rockville, two message-input areas are represented. The first is a customer-premises area, electronically remote from the station itself. This contains a variety of devices representative of those that the "customer" could use to electronically enter messages into the system from his own facilities. These are coupled to the remainder of the ETS by dial-up telephone lines. The second input area is a simulated postal lobby. Here customer physical media inputs are accepted, logged and electronically inducted into the system. The remaining area is the station itself, including processing, printing and communication capabilities. With that background, we can review the system in further detail, beginning with the customer-premises area.

Customer-controlled equipments include two representative conventional office facsimile units, a QWIP-1200 and a Xerox TC400, which scan at 96 lines/inch and complete a page in six minutes. These access the PDP-11/70 by dialed telephone lines and appropriate modems. To allow these facsimile devices to be used to enter mail, they are used in conjunction with a simple telephone-company-supplied keyboard and display supported by software developed by RCA. The purpose of the keyboard and display is to allow the

user to instruct the computer with regard to destination address, number of pages and the like. The computer will need this information to check the submittal for completeness and to route the message. The computer sends "prompts" back to the display to indicate to the user what data is to be keyed in. A second input device in the customer area is the cartridge-tape system that also accesses the 11/70 by dialed telephone line. This uses convenient, compact, magnetic-tape media that could be used by mailers who do not need the letter handling capacity of a larger tape input system. But nothing precludes the use of a large tape system in a similar manner. These tapes contain addresses and instruction information as part of their coded data, and no separate input keying is necessary. Two word processors are included in the system, an IBM system and a Xerox 850. Letter data, once entered into word processor memory, are sent in synchronous mode to the 11/70 over dialed phone line using the 2780 protocol. Data acceptance into the computer is fully automatic.

We now turn to the lobby window area where physical media inputs are accepted. In ETS, these inputs are magnetic tapes, magnetic floppy disc (diskette), packeted paper letters and single paper letters. At



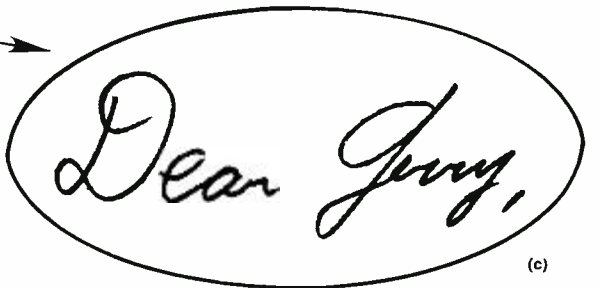
Physical media "handed over" to the ETS station included floppy disks from word processors, magnetic tape from computers, typed sheets in OCR-A font. Other paper letters, not in this font, are handed over for "clerk"-assisted high-resolution facsimile induction.

CUSTOMER ID. MMC	RETURN ADDRESS	DESTINATION ADDRESS
MESSAGE ID. 1	NAME	NAME G. TILKER
SERVICE P <input checked="" type="checkbox"/> R <input type="checkbox"/>	STREET	STREET 123 FIFTH ST.
NO. PAGES 1 <input type="checkbox"/> 2 <input checked="" type="checkbox"/> 3 <input type="checkbox"/>	CITY STATE	CITY STATE NEW YORK, N.Y.
TEXT ID.	ZIP	ZIP 10001
FONT C B G R		

Dear Jerry,

Here is a copy of the Router & Trimmer Accessory catalog sheet you asked for.

Joe Q.



Letters may be entered via conventional low-resolution 96-line/inch facsimile in an office and passed to the ETS station via telephone line. Or, a letter may be carried in for induction by high-speed high-resolution facsimile. Figure (a) shows a letter for facsimile. Figure (b) shows part of that letter, induced by low-resolution facsimile, as finally printed by the ETS. The effect of low-resolution thresholding is visible. Figure (c) shows the output from high-resolution induction and thresholding.



\$HDR

MMC/301/1//MMC4/IM/155L/C/R/P

///

Mrs. Terry Tracy

80 Front Street

Rockville, MD

20852

\$TXT

Dear Mrs. Tracy:

We are sorry to know from  
ordered as a birthday gift  
badly marred that you can

As the Long Island Railroad  
the radio was satisfactorily  
received, it must have been  
derailment they had recently  
up to the railroad company,  
disappointment when you  
husband was not in good  
sending you at once and  
ordered.

If you will ask the express



MANUAL MANUFACTURING  
COMPANY

MANUAL MFG. COMPANY  
7114 INDUSTRIAL HWY  
GREAT MILLS, MD 20634

MMC R UO 000301  
09-05-80 12:40  
09-05-80 12:51 00:11

Mrs. Terry Tracy  
80 Front Street  
Rockville, MD 20852

|||||

Dear Mrs. Tracy:

May 2, 1979

We are sorry to know from your letter of May 12 that the radio which you ordered as a birthday gift for your husband arrived with the cabinet so badly marred that you cannot accept it.

As the Long Island Railroad Company gave us a receipt acknowledging that the radio was satisfactorily crated and in good condition when it was received, it must have been damaged in transit (probably as a result of a derailment they had recently). Although the responsibility is really now up to the railroad company, we realize what must have been your disappointment when you found that the gift you purchased for your husband was not in good condition for his birthday. We are, therefore, sending you at once another cabinet exactly like the one you originally ordered.

If you will ask the express company to make a special delivery as soon as the radio arrives at the station, we hope that you may still receive it in time for your husband's birthday.

Please leave the damaged radio with the railroad company, and we shall ourselves enter a claim for it. You will then have no further trouble.

We thank you for notifying us promptly. We want you to know our first desire is that you should receive your order promptly in perfect condition.

Yours truly,

I. Makum  
New Products Manager

(a)

(b)

By arrangement with mailer, certain repeatable letter components may be stored in the system. These may be text, logos, signatures, business forms. The printer contains various type fonts in memory. Figure (a) shows an input letter on paper medium typed in OCR-A. Figure (b) is the resulting ETS output. The logo, letterhead and signature were called from storage by the instructions at the top of Figure (a). The output point was also designated in the header. The bar code was generated from the recipient's address.

this window the submittal is accepted, logged in the computer and a receipt is given. Tape is put on a tape reader for induction into the system, and floppy discs are similarly placed into a disc reader. Paper letters, if individual, are accepted by the "clerk" who will enter the letter into a high-speed, high-resolution digital facsimile unit. He keys in address and header instructions, much as in the customer facsimile input terminal dis-

cussed earlier. This high-speed facsimile, specially developed for this program by Stewart-Warner, provides 200-line per inch resolution, and automatic contrast-threshold adjustment. A page is read in ten seconds and RCA-developed software reads 3.6-million bits to disc in that time. The software uses reflectivity measurements made by this device to calculate contrast and to alert the operator if contrast is insufficient. Stacked paper

letters are typed in one of the special fonts suitable for automatic OCR reading. In ETS, OCR-A font is used. Address and other instructions are contained at the head of the sheet and are directly read and understood by the system, saving individual keying by the clerk for each letter. While input is in OCR-A font, the final printed letter is in any of the four fonts in the ETS-printer firmware that the mailer may designate in the header. This output

font selection is also available, of course, for data input by tape and other magnetic media.

Letter data are entered into the data processor, and are stored on magnetic disc. The mailer's account status is checked and "postage" charged against his account. The input is also checked for consistency and correctness by means of information entered in the header, including consistency of header with letter content, consistency with user's account, and consistency with already-stored data if required. For example, the software program will determine if the message text is intended to be stored for re-use in a number of letters, and it will determine if such a text, or a designated format, or signature is stored in the system. Once data are in the system, they are again checked to determine if they are intended for this station, or for one of the two distant stations. If they are for the distant stations, they are queued for transmission to those (simulated) stations. Data for "New York" exit over a 56-Kb/s Dataphone Digital Service (DDS) leased line which is routed out of the Laboratory to a telephone switching center and back. The returned data then reenter the processor. They are then placed in a distinctive computer file representing

"New York." Mail for "Los Angeles" is directed to the satellite ground terminal outside the building and transmitted at 56-Kb/s to a domestic communications satellite. From the satellite, the data are returned to this ground terminal and entered into a separate "Los Angeles" file in the processor. This satellite equipment is supplied by RCA Americom.

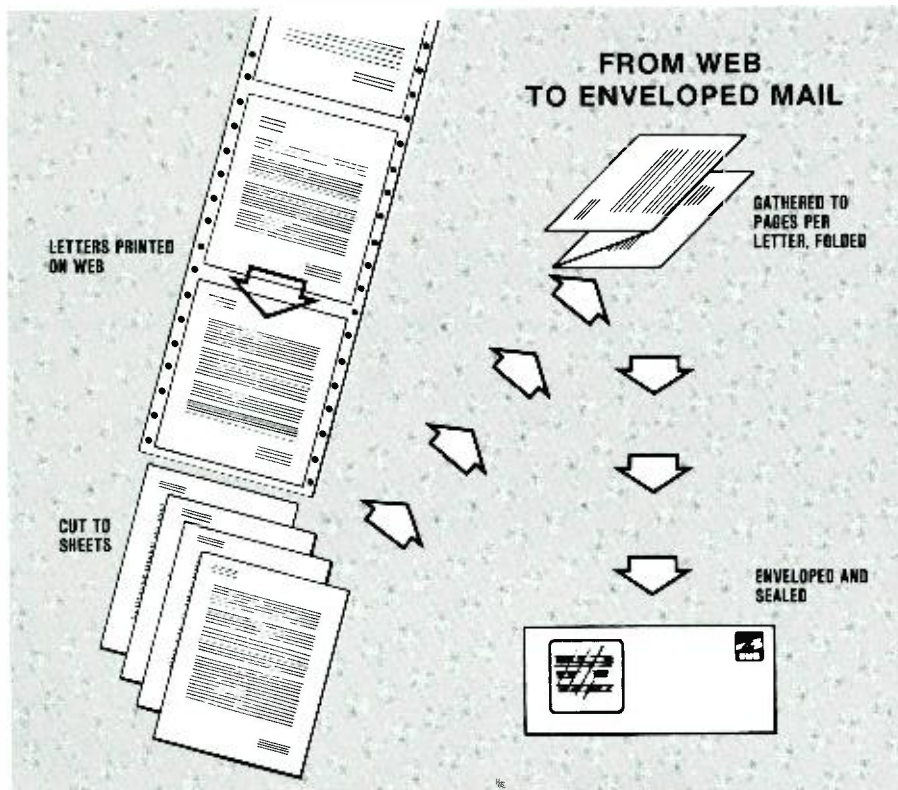
Once back in the proper computer file, the letters are ready for sortation. At the operator's option, ETS can sort to ZIP, or to the carrier's street-walk sequence, or to Box "hold-out." A Nixie output is created for letters whose address is not "legitimate" for the ETS territory. The carrier-walk sorting is demonstrated for an actual small segment of Washington, D.C., using real delivery routes. The mail-stop number sequence along these route segments is stored in a computer directory. In the future, ETS can be expanded to the nine-digit ZIP, and the capacity to do so is already built into the system.

In addition to "regular" service, the ETS handles "priority" letter mail. Such mail is served first by the system; and the system can be commanded to sort and print priority letters before other letters. As a selectable option, the system will sort on the basis of total number of letters ac-

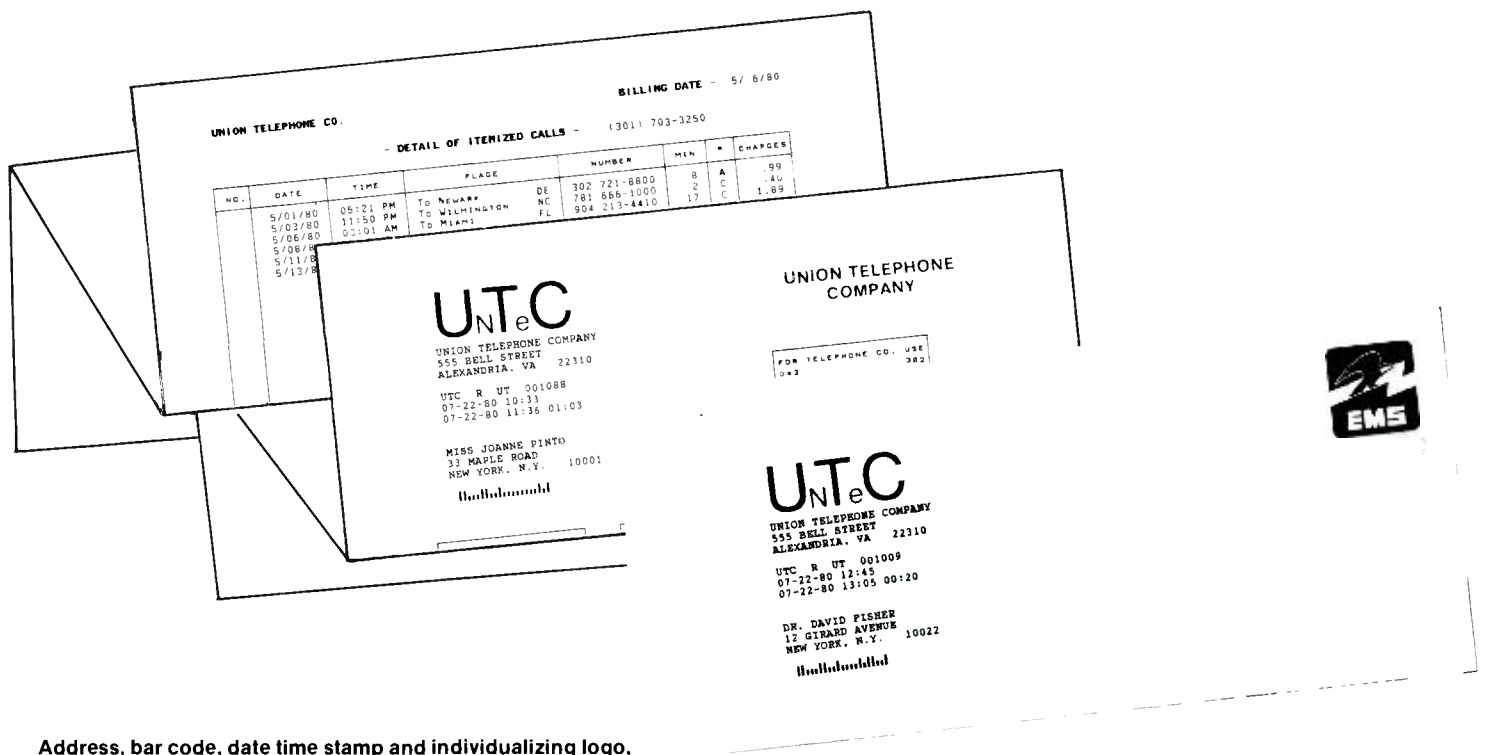
cumulated; or total elapsed time; or when memory is almost full; or anytime on command. Separate sort-volume and time thresholds may be set for each of the three cities, and for priority versus regular service.

At this point some of the features of the ETS not discussed already need to be mentioned, as they are representative of processing in the mature electronic mail concept. It will be noticed that the ETS is not a facsimile system. Rather, it processes a mix of letters, some of which originate as facsimile inputs, but most of which originate as alphanumeric character inputs. Alphanumeric inputs are those derived from tape, floppy disc, OCR and word processor. These alpha modes are preferred to facsimile whenever possible because such inputs are very compact in information content. ETS implements further data economies. For example, it has been mentioned that when a message consists of one text and multiple addresses, the text can be submitted once together with the address list. Or that text could have been previously stored in the computer, ready to be combined with a fresh address list. The same type of one-time input or pre-storage is provided for logos, signatures and business forms. Since these do not have to be submitted, stored or transmitted for each letter individually, great data-handling economies result. For purposes of demonstration, nine fictitious logos, ten formats and fourteen signatures were pre-entered and stored in the ETS processor. The logos and signatures were entered by means of the high-resolution digital facsimile operating in an "off-line" mode. Forms can be introduced to storage in the same manner. However, in the ETS, form-generating characters are used instead, producing an output with a "crisper" appearance.

Thus, certain stored letter components and certain current letter-input components are combined in the computer before printing, based on instructions contained in the letter-input header. When this composition under computer program direction is complete, the letter data is sent to the printer. The printer is a specially modified Versatec 1200A, writing electrographically on treated fanfold paper. After the letters have been printed, along the fanfold web in sorted order, the web is transferred to the envelope. The envelope trims away the margins containing the sprocket holes and cuts the letters into 8½ x 11-inch sheets. These sheets are then accumulated automatically to the proper number of sheets in each



**Printing takes place along a web of sprocketed paper.** The letters are printed in sorted order. In the ETS, this can be down to a carrier's neighborhood-walk sequence. The envelope cuts the web into sheets; accumulates one, two or three sheets per letter; and folds, inserts and seals the letter in an envelope.



Address, bar code, date time stamp and individualizing logo, as they appear in the window of an ETS letter.

letter, anywhere from one to three, then "zee" folded, stuffed in an envelope and sealed. The destination address is printed in a location that shows through the envelope's window. A ZIP bar code is also printed in the window area, as is the clock time of message input and output.

At the end of the ETS "day," the system can generate reports of various data and statistics relating to the performance of the system. These include an accounting report indicating "customers'" credit status and pre-paged postage balance; a traffic report indicating amount of utilization of system components; a missed schedule report indicating the number of letters not meeting service time schedule; and a system performance report indicating the history of errors within the system.

Finally, the system can be commanded to generate mailer-account statements in the form of a letter for mailing.

## Conclusion

Studies carried out to date clearly show the technical, operational and service feasibility of a postal electronic mail system. This system, at maturity, is projected to handle some 25-billion mail pieces per year. Its services include tape, diskette, packeted letters, individual letter and limited communications input. Output is exclusively carrier-delivered letters. These letters will contain essentially all of the structural features present in today's letter mail. For the system approach which was selected

and recommended as the result of study, substantial relative and absolute reductions in the cost of postal letter processing operations is projected.

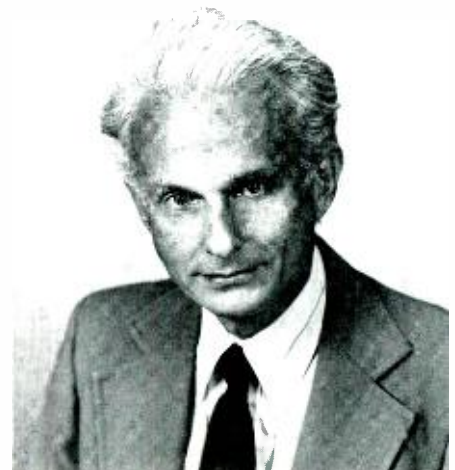
The system necessarily will begin in relatively few cities with a reduced body of services. At the same time, it is important that augmented service offerings be available at these locations to allow market reaction to such services to be evaluated. These reactions are the guide to the kind of expansion and the rate of expansion which the system will require.

A reduced-scale laboratory version of

the system was built and installed at the U.S. Postal Service Laboratory in Rockville, Maryland in order to demonstrate and test many of the features of the electronic mail concept. This system does in fact demonstrate numerous of the many and complex functions of the projected system. The experience gained in developing the system, the hardware and software problems overcome, the further knowledge garnered even in its initial use, will be invaluable in allowing the Postal Service to move with minimum risk to a first operational electronic mail system.

**Manny Robbins** is Manager of the Electronic Mail Programs in GCS. He joined RCA in 1967. For the past three years he has been Manager of Electronic Message Service System (EMSS) Engineering, responsible for all technical efforts in the EMSS, the System Validation and Testbed (SVTB) and the Evaluation and Test System (ETS). Before his first involvement in EMS studies 8 years ago, Mr. Robbins organized and directed concept studies for a System Control Subsystem (SYSCON) for application to the Army Field Tactical Processing System and was Technology Manager on the Mallard Communication System Study for the Army.

Contact him at:  
**Government Communications Systems**  
**Camden, N.J.**  
**TACNET: 222-2701**



# Advanced Satcom: RCA's next-generation domestic satellite system

*The new Americom satellite earth and station designs will retain many of the older characteristics, for compatibility, but will double the traffic capacity per channel and ensure a ten-year mission life.*

---

**Abstract:** Channel demands on the RCA Americom domestic satellite communications system continue to increase rapidly. Therefore, Americom plans a system expansion both in the number of satellites and in the traffic capacity per satellite. In the early 1980s, RCA Americom will introduce a larger, second-generation satellite design that exploits the economy and payload capacity of the updated Delta launch schedule. System profitability studies show that this expanded domestic network should remain at C-band (6/4 GHz), with traffic capacity per satellite increased by a combination of higher EIRP, improved filter

characteristics, and more advanced terrestrial equipment. Increased propellant capacity, additional component redundancy, and greater power system capability will extend the satellite's life and reliability. Earth station improvements to complement these spacecraft features and to thereby double the per-transponder channel capacity include modifications to the RF stages of the terrestrial facilities and development of more efficient modulation techniques. The resultant lower annual cost per channel will allow Americom to offer new services as well as to expand the present customer base.

The first two 24-channel RCA Satcom satellites (Satcom I and II) were so fully loaded during their four years of service that RCA planned a third satellite for service in early 1980. The Satcom III (F-3) satellite had the same channelization and effective isotropically radiated power (EIRP) as Satcoms I and II, but carried four spare traveling-wave tube amplifiers (TWTA) and higher-capacity batteries to assure improved reliability throughout its

projected eight-year design life. Unfortunately, contact with the satellite was lost after ignition of its apogee motor. The fourth and fifth satellites of this series are now in production for launch in 1981. They will replace the F-3, and supplement the already saturated Satcoms I and II.

Design changes to these spacecraft, in addition to transponder redundancy, will extend their orbit life to ten years, support improved communication-subsystem performance and provide a superior attitude-control system.

With plans to replace the first two

satellites in 1982-3 and to expand the satellite constellation, RCA Americom has selected a second-generation spacecraft design that has a higher traffic capacity and a lower cost-per-transponder per year. Like the original series, the Advanced Satcom satellites will be designed, fabricated and controlled into orbit by RCA Astro-Electronics. The updated Thor Delta 3910 launch vehicle with its launch economy and weight capability will put increased revenue-producing payload into geosynchronous orbit. Complementary improvements in ground stations and transmission equipment will assure that spacecraft enhancements are used efficiently to maximize system capacity and profitability.

## System requirements

The RCA Americom system serves four distinct domestic communications traffic markets — commercial, government, video/audio and Alaska.

*Commercial Communications Services* provides private leased channels for voice, data and facsimile traffic Messages travel via earth stations serving the metropolitan areas of New York, Chicago, San Francisco, Houston, Atlanta, Los Angeles and Denver. A major additional

facility in the Miami area is planned for late 1981.

*Government Communications Services* provides voice, video and high-speed data services to federal agencies (NASA, DoD, NOAA, etc.) via RCA-owned earth stations located on various government installations.

*Video and Audio Services* provides point-to-point and point-to-multipoint distribution of television, radio and news services to broadcasters, cable-TV operators and publishers. The network of receive-only stations owned and operated by the CATV industry has expanded most rapidly with approximately 3000 such stations now being served by the RCA Satcom system.

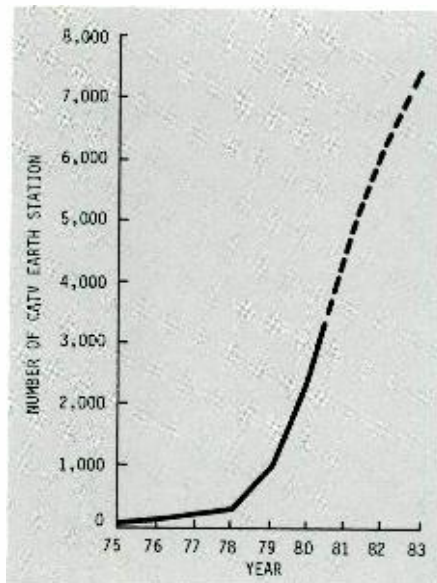
Figure 1 shows the phenomenal growth in the number of CATV earth stations since Home Box Office and RCA began satellite distribution of cable television programming in 1975.

*Alascom Services* gives Alascom, Inc. (the long-distance common carrier for Alaska) the satellite capacity for interstate and intrastate message and video transmission.

The fundamental imperative of commercial viability must be followed as the Americom system expands to serve the growth of these four business sectors. To this end, technological enhancements are measured against the twin benchmarks of improved performance and return on investment. The primary technical objectives of the system expansion are to increase traffic capacity per satellite, to assure longer satellite life with improved reliability and to make the satellite compatible with existing terrestrial and space facilities. Realizing a profit without sacrificing these primary objectives results in a system expansion plan that depends primarily on product enhancement rather than product innovation. Americom chose this approach because of two major technical and economic trade-offs: specialized versus general-purpose satellite design; and C-band (4/6 GHz) versus K-band (12/14 GHz) service.

### *Specialized versus general-purpose design*

Optimized configurations that permit comparative advantage within a given market are the goals when we select specialized satellites and earth station types for each of the four classes of business supported by the Americom system. For example, for cable television the transponder bandwidth



**Fig. 1. Cable earth station growth.** Rapid CATV growth to date will continue into the near future.

could be reduced by one-third to allow 50 percent more channels within the allocated 500-MHz bandwidth. Such transponder bandwidth reduction would yield a lower cost per channel and more channels per spacecraft, but a unique design for this one type of traffic makes service restoration difficult and adds costs, for modification of the many existing receivers, to CATV systems.

Furthermore, a large investment in a specialized system is only appropriate when the market is stable, mature and predictable. This is scarcely the case in commercial satellite communications — new technologies, services and markets appear constantly. But new satellites and earth stations that are compatible with existing facilities obviate plant modification costs and simplify service restoration in the event of catastrophic failure, a feature of great significance to satellite users. Satellite design decisions that ensure this compatibility with large existing networks include the choice of frequency band, transponder channelization, polarization, interconnectivity and uplink and downlink power levels.

### *C-band versus K-band*

We evaluated K-band operation for the Americom system, either in lieu of or in addition to C-band operation (that is, using either dedicated or hybrid satellites). Our evaluation focused on two key questions. Firstly, would K-band enable RCA to penetrate and develop profitable

but otherwise inaccessible communications markets? Secondly, would K-band be needed to accommodate the forecasted growth of the four Americom business centers?

Although radio-frequency-interference (RFI) congestion of terrestrial microwave networks does not limit K-band station locations, frequency coordination for C-band stations has become less formidable now because interference levels can be precisely measured on-site and natural or artificial shielding can be judiciously used. Rooftop antennas for the customer — K-band's appeal — are already being realized at C-band in numerous major business and government facilities located in suburban areas removed from metropolitan RFI congestion. Although K-band has no proscribed downlink flux-density limits, the C-band limit is on flux-density per unit bandwidth. Therefore, we can use adaptive energy dispersal, in which the energy spreading waveform is inversely proportional to the signal level, to meet the C-band limit without sacrificing a constant fraction of the frequency deviation — and hence signal-to-noise (S/N) — for dispersal purposes.

Large downlink margins are required at K-band to overcome the deep fades due to precipitation in the transmission path. These margins dictate that high-power transmitters — necessarily, TWTAs for the next decade — be used. On the other hand, lower-power C-band amplifiers can employ the more reliable solid-state technology of gallium-arsenide field-effect transistors (GaAsFETs). Lastly, the economic attraction of a hybrid satellite with greater spectral capacity diminishes when we consider the practical difficulties of orbit slot complications due to different spacings for C-band and K-band satellites (4° and 3°, respectively) and to high restoration costs and operational complexity when partial failures occur.

RCA Americom concluded from these studies that it can most profitably serve its traffic markets for the near future by concentrating current investment in efforts to upgrade its C-band system via earth station improvements, and to build a second-generation satellite with increased capacity. Overall traffic projections can be accommodated at C-band by a system design that doubles the per-transponder capacity and deploys additional satellites into unused orbital locations. In view of the dramatic increases in demand for satellite communications services and orbital positions, RCA Americom maintains ongoing efforts aimed at the evaluation of

K-band operation as a means of increasing Satcom system capacity and performance.

## Spacecraft design

The economic analysis of the total Americom network showed that 24-channel, frequency-reuse, C-band satellites are the most profitable approach to providing the mixed types of service needed. Therefore, the design criterion for the second generation of satellites is again maximum communication capacity per unit cost. This criterion demands a system design that increases the traffic capacity and availability of each channel and reduces the life-cycle costs that are based on spacecraft hardware development and launch charges. Americom wants to lengthen the revenue-producing life of the satellite, of course, because the corresponding reduction in annual depreciation expense contributes directly to the return-on-investment of this capital asset.

An important consideration in the design of this spacecraft has been the selection of launch vehicle. Two expendable vehicle series are currently available — the Delta and the Atlas Centaur. Two new vehicles are scheduled for the mid-80s — the reusable U.S. Space Shuttle and the expendable European Ariane. Technical problems have delayed the Space Shuttle service, originally planned for 1980. Although the significantly lower costs of shuttle launch are very attractive, the Space Shuttle obviously will not be available to launch the Advanced Satcom in the fall of 1982 or spring of 1983. Similarly, the unproven Ariane's availability is uncertain, and a launch from the French pad in Kourou, French Guyana would introduce logistic complications. The uprated Delta 3910 costs appreciably less than other Delta and Centaur vehicles and more closely matches the size and weight payload suitable for Americom's mission. The Delta 3914 used for Satcoms I and II, for example, has a transfer-orbit payload capacity of 2050 pounds. The 3910, on the other hand, can put approximately 2400 pounds into the same orbit because it uses different staging of the larger solid strap-on booster rockets and a larger third stage, the PAM-D. This third stage is a common stage based on the Thiokol STAR-48 solid rocket motor. It is compatible with the Delta 3910. This stage can also be used on the Shuttle as a perigee-assist module (hence its name, PAM-D) to inject a spacecraft into synchronous transfer orbit from the Shuttle's low parking orbit.

**Table I. Spacecraft salient features.** Performance and lifetime of Advanced Satcom have been increased significantly with only a small increase in launch weight.

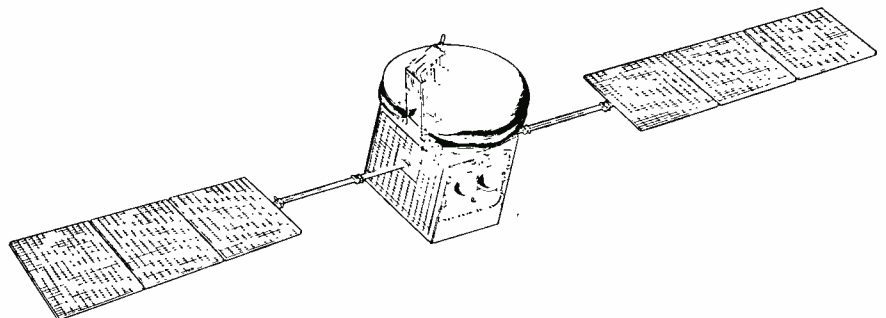
Item	Description/Value
Launch Vehicle	Delta 3910/PAM-D
Mission Life	10 years
North-South Stationkeeping Accuracy	$\pm 0.1^\circ$
East-West Stationkeeping Accuracy	$\pm 0.1^\circ$
Eclipse Capability	100% (24 channels fully powered)
Stabilization	three-axis
Transfer Orbit Weight	2431 pounds
Channelization	24 transponders 12 each on orthogonal polarizations
Redundancy	28-for-24 SSPA, 4-for-2 receivers
EIRP/Channel	
CONUS	35 dBW
CONUS/Alaska	34 dBW
Hawaii	26 dBW
Receive G/T	
CONUS/Alaska	-3 dB/ $^\circ$ K
Receive Frequencies	5925-6425 MHz
Transmit Frequencies	3700-4200 MHz
CR&T Frequencies	
Uplink	6423.5 MHz
Downlink	3700.5 and 4199.5 MHz
Array Power (Minimum @ 10 yrs)	1050 watts

## Spacecraft configuration

Although the Advanced Satcom spacecraft will be larger and heavier than the first-generation spacecraft now in service, it will retain the basic features of its predecessors: three-axis body stabilization, sun-oriented solar panels, and cross-gridded antenna reflectors for frequency reuse, as shown in Fig. 2. Propellant supply, power-system capacity, and component reliability/redundancy will be sufficient to ensure that all channels operate continuously for ten years. To achieve greater traffic capacity within the 24 channels, we will incorporate technological advances over the present designs into each of the major com-

munications subsystem elements. For example, a shaped-beam antenna increases gain over the coverage area; an improved receiver (lower noise temperature) further increases uplink carrier-to-noise; sharper multiplex filters decrease crosstalk and distortion noise; and higher-powered amplifiers with improved linearity reduce intermodulation distortion and permit greater capacity. The attitude and velocity control systems will be modified to match the larger structural configuration, as will the array size and battery capacity to support the higher power consumption of the payload.

Leading particulars of the Advanced Satcom are given in Table I.



**Fig. 2. Advanced Satcom on-orbit configuration.** Second-generation Satcom features new antenna design and larger solar array for more traffic capacity.

## Communications subsystem

The Advanced Satcoms will serve the same geographical areas of the expanded Americom network as those presently covered — CONUS, Alaska and Hawaii. But the antenna design will be more sophisticated to achieve higher gain over those areas and also to adapt to the relatively wide spacecraft longitudinal range to be accommodated. We must shape the antenna beam pattern to approximate the coverage area. This demands that we use an oversized antenna reflector, together with multiple feed horns whose size, location, power division and relative phasing are the design variables in achieving the required gain control.

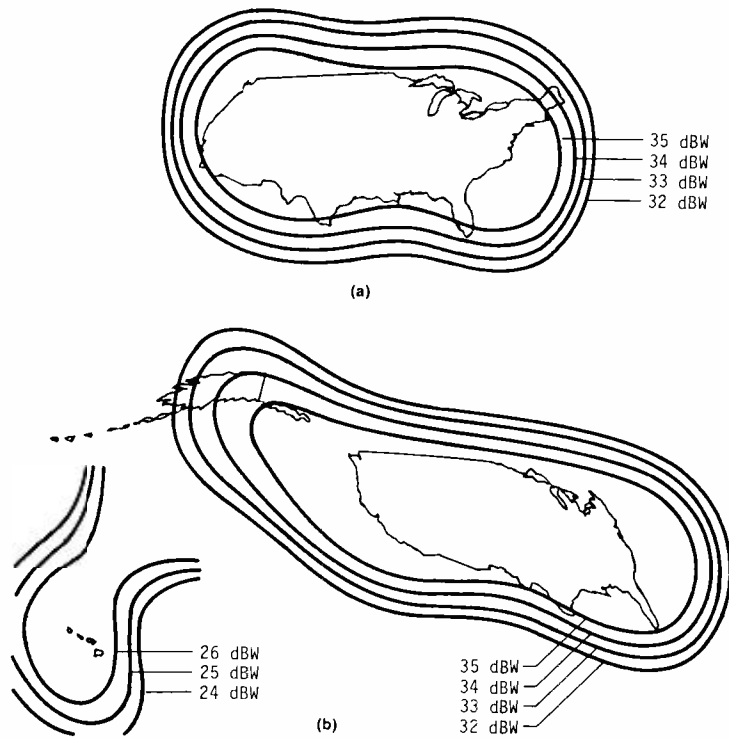
A major consideration in antenna design is CONUS-Alaska versus CONUS-only coverage. Americom has chosen two generalized beam shapes, as illustrated in Figs. 3a and 3b, for eastern and western orbital locations. Thus, we plan pre-launch adjustment of the feed power-splitting and phasing network for specific beam shapes, since orbital stations will generally be pre-assigned

As on the current Satcom satellites, the reflector is composed of overlapped, cross-gridded surfaces to achieve the two orthogonal linear polarizations. The axial separation of the two surfaces provides a corresponding separation of their focal points that accommodates multiple sets of feed horns.

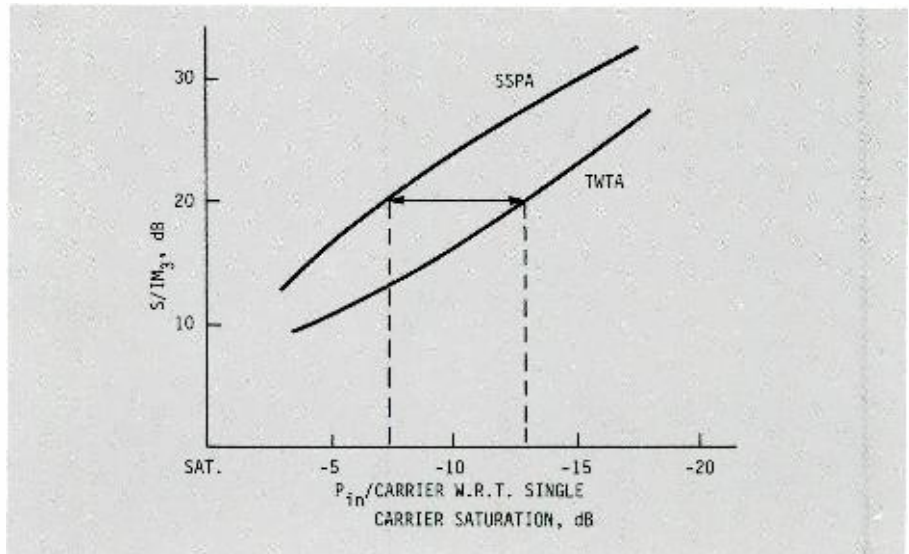
## Transponder enhancements

Each element of the transponder incorporates design improvements that, together with the higher antenna gain, double the traffic capacity per channel of our current satellites. The receivers use GaAsFETs in both the 6-GHz preamplifier and 4-GHz driver sections to achieve greater than 3-dB improvement in noise figure. Advanced multiplex filter designs realize sharper channel band-edge attenuation with lower inband gain slope (and thus reduced crosstalk). These advanced designs have six-pole group-delay-equalized elliptic function characteristics for the input filters and four-pole, elliptic-function response for the output filters.

All-solid-state GaAsFET power amplifiers (SSPA), used in lieu of TWTAs, will significantly improve both the performance and reliability of the final amplifier. In comparison with a TWTA, the SSPA is a more linear amplifier, particularly near the full-power operating point. This



**Fig. 3. Advanced Satcom EIRP coverage. (a)** Eastern orbital positions. **(b)** Western orbital positions. Antenna "footprints" are matched to the service area for maximum efficiency.



**Fig. 4. Amplifier linearity comparison.** SSPA linearity results in lower intermodulation distortion than available with TWTA.

**Table II. Increase in channel capacity with power amplifier linearity.** Lower intermodulation distortion with improved linearity allows greater traffic within the same bandwidth.

Traffic Mode	Channel Capacity Increase SSPA to TWTA
FDM Single Saturated Carrier	4%
FDM-FDMA	
Two Carriers	10%
Six Carriers	25%
Single Channel Per Carrier (SCPC)	50%

linearity of the power transfer function, with less gain compression at the nominal saturation point, is exhibited in terms of the level of intermodulation between two (or more) carriers. With the SSPA, as shown in Fig. 4, the signal-to-third-order intermodulation distortion between two carriers is 3 to 8 dB better than with the TWTA. Hence, to achieve a given signal quality, for example 20-dB S/IM<sub>3</sub>, the input back-off required for the SSPA is approximately 5dB less than that for a TWTA, thus providing a higher signal-to-noise ratio and resultantly greater channel-traffic capacity. Table II summarizes the results of calculations to determine the incremental capacity available due to the superior linearity of solid-state devices *vis-a-vis* TWTAs. This table compares an SSPA and TWTA of equal output power. Additional capacity increases are realized when other transponder enhancements — for example, improved G/T, filters, antenna gain and so on — are considered.

The Advanced Satcom transponder, by virtue of SSPA linearity in combination with phase-equalized elliptic function filters, can support two simultaneous video transmissions with high quality and without crosstalk.

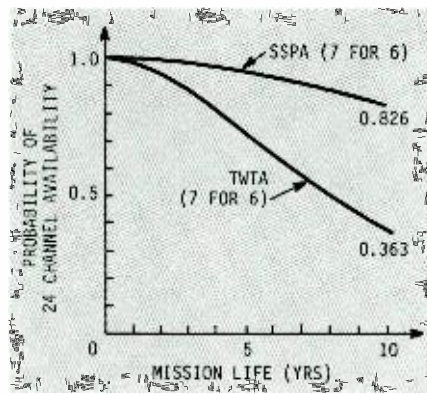
Elimination of the hot-cathode life-limitation and high-voltage power-supply complexity of TWTAs will greatly increase the probability that the amplifier will survive the full ten-year mission. A spare SSPA, installed for each of the four groups of six channels, also increases transponder reliability. The improved availability of all 24 channels throughout the mission life is illustrated in Fig. 5.

## Spacecraft bus

### Power subsystem

Increases in the mission life (to ten from eight years) and in the transmitter power of each channel necessitate an uprating of the basic RCA Satcom power system, now composed of a single-axis-drive solar array and three independently charged batteries. The required array area for the total communications payload plus spacecraft-bus DC power, including battery recharging, of 1050 watts, is 120 square feet. The array is six panels of high-efficiency, thin-junction cells. Continuous operation of all 24 transponder channels throughout the maximum 72-minute eclipse period is supplied by 150 pounds of nickel-cadmium (NiCd) batteries.

Nickel-hydrogen (NiH<sub>2</sub>) cells continue to be evaluated at RCA, but do not have



**Fig. 5. Power amplifier availability comparison.** Lower parts-count and absence of filament-heated cathode contribute to higher reliability of SSPA compared to TWTA.

enough statistical data supporting their performance for use in 1982. As demonstrated by Satcoms I and II, the proper combination of cell design, depressed operating temperature, full-discharge reconditioning and trickle charge can provide long life with NiCd.

Like the current Satcoms, the elimination of any central regulator or battery-boost circuitry leads to maximum reliability and minimum weight in the power system. The various subsystems, all of which contain DC-DC converters for their particular requirements, perform distributed regulation. Hence, the bus voltage ranges from a maximum of 35.5V, when power is supplied by the array, to a minimum of 23.5V battery voltage at the end of maximum eclipse with full 24-channel load.

### Attitude control

Precision three-axis body stabilization will again be accomplished with the basic RCA Stabilite® design of fixed-pitch momentum wheel together with autonomous magnetic torquing (and thruster backup) for keeping the angular-momentum vector normal to the orbit plane. The placement of the solar array shaft through the on-orbit center of mass simplifies north-south stationkeeping maneuvers. Orbit-inclination-control thrusters displaced symmetrically about the shaft minimize roll-and-yaw disturbance torques due to thruster plume impingement on the array. Thruster firing can occur at all array positions throughout the day. Micro-processor control will be introduced for operating the thrusters for both north-south and east-west stationkeeping and for momentum adjustment.

## Reaction control subsystem

Transfer-orbit attitude-torquing and synchronous-orbit velocity-control will be supplied by a fully redundant, 12-thruster, four-tank monopropellant system. The integral blowdown tanks containing surface-tension fuel-management screens are sized for the ten-year mission and greater spacecraft mass. Similarly, larger thrusters will be used to assure sufficient throughput capacity for the ten-year fuel budget.

## Apogee motor

The solid-propellant apogee kick motor (AKM) is designed to transfer the spacecraft from the inclined, elliptical, transfer orbit to the equatorial, geosynchronous orbit. An integral part of the spacecraft, the AKM is fired at the apogee of the transfer orbit to change the velocity and the plane for injection into a circular, synchronous orbit.

The AKM is the Thiokol STAR-30 (a new engine not used on previous Satcom missions) specifically designed for Thor Delta 3910/PAM-D and Shuttle/PAM-D geosynchronous applications. It provides a total impulse of 326,947 lbs.-sec.

## Structure and thermal control

The spacecraft structure—designed for increased weight, higher thermal dissipation and the new antenna—retains the Satcoms' rectangular box of aluminum honeycomb panels supported on a cylindrical center structure in which the apogee motor is mounted. Four bulkheads join the side panels to the cylinder along its length. A lower-transition cone provides the proper interface for mating with the PAM-D adapter.

Transponder and other subsystem components are mounted on the removable north and south panels. The absence of components on the east and west panels makes the interior of a fully assembled spacecraft accessible, facilitating testing and adjustment before the launch.

Figure 6 shows an exploded view of the spacecraft structural arrangement. The assembled view, with folded solar panels as mounted atop the PAM within the Delta fairing, is shown in Fig. 7.

## Terrestrial network enhancements

Along with the improvements in satellite EIRP, amplifier linearity, and channel



response described above, concomitant enhancement of terrestrial equipment characteristics will be implemented to realize the objective of doubling the traffic capacity per standard 40-MHz transponder channel. A critical component of system capacity is the G/T of the receiving earth stations in the system. Americom has under way a program to upgrade this figure of merit via the use of recently available thermoelectrically cooled low-noise amplifiers (LNAs) providing noise-temperature performance on the order of 35°K. Cryogenically cooled amplifiers, which held sway for so long in satellite communications systems, are giving way to units of this kind because of the inherently superior reliability and reduced maintenance expense of the non-cryogenic devices.

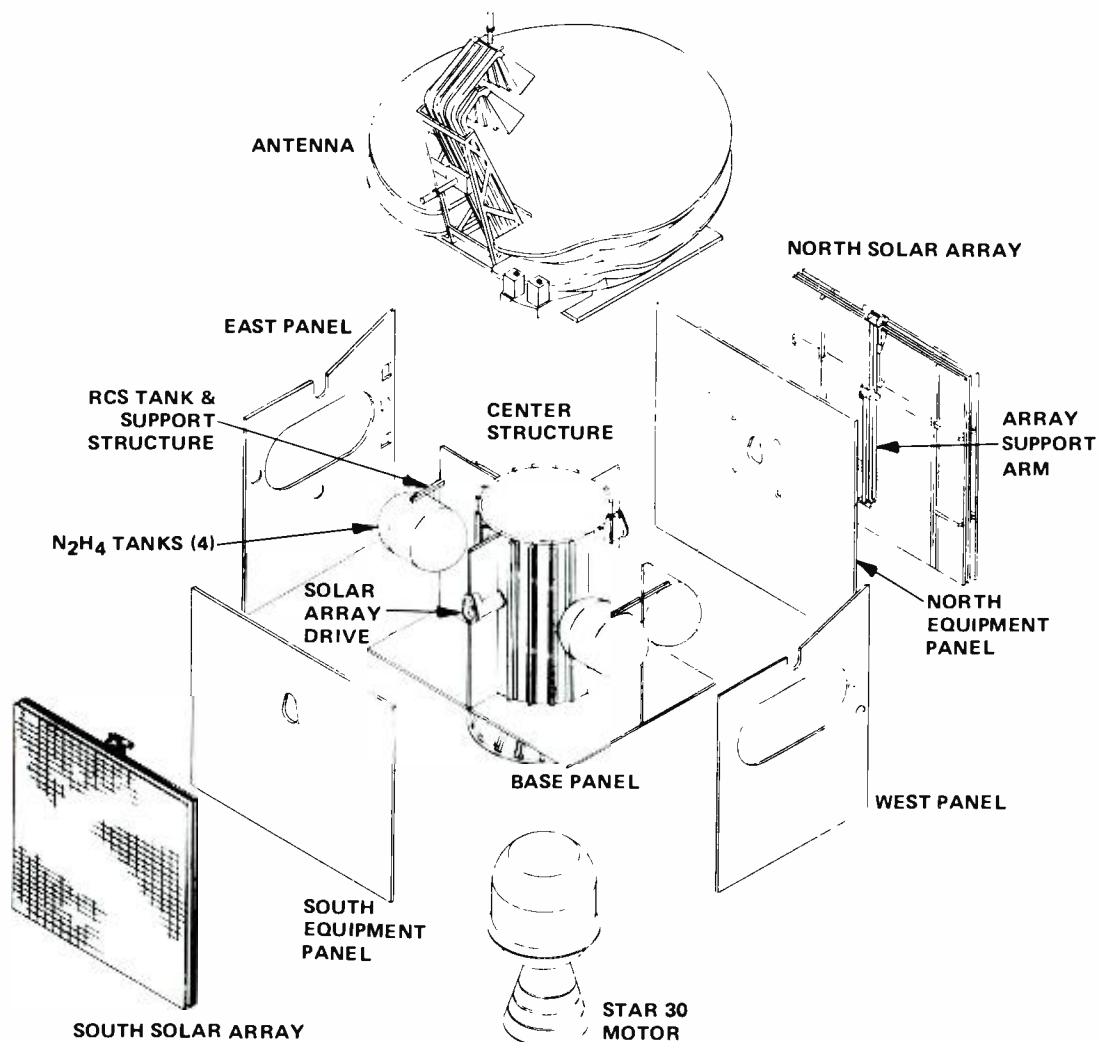
In addition to greater receiver sensitivity, the existing capacity of FDM/FM carriers is increased from 1000 to 2000

circuits by companders. Companders compress the dynamic range of a voice signal prior to transmission through the satellite channel, and then expand it to its original range at the receiver. The attenuation of channel noise during idle periods that contain no voice activity, results in an improvement to the channel signal-to-noise ratio. This enhanced S/N can then be reduced to the original S/N level (51 dB, earth station to earth station) by decreasing the per-channel FM deviation. This allows the addition of more channels to the FDM baseband, at no loss in perceived quality to the end user. Companded voice channels, because of their reduced signal-to-noise ratio, are relatively insensitive to distortion noise (noise introduced by non-linear amplitude and phase characteristics of transmission channel filters). This characteristic allows the use of overdeviation techniques in which additional channels are added to the FDM baseband.

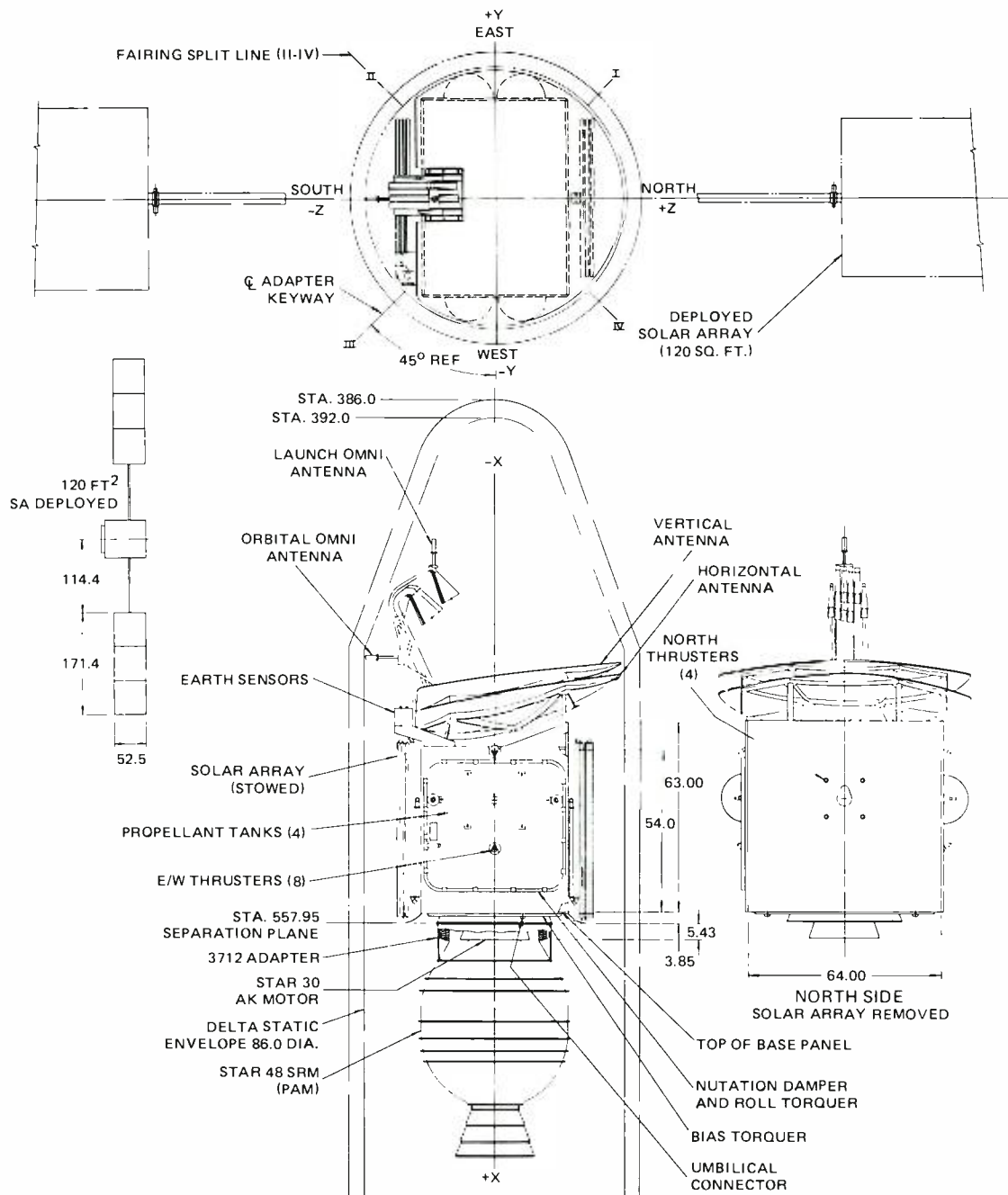
These techniques result in an RF deviation in excess of the Carson's Rule bandwidth.

Another feature that makes system capacity expansion possible has been the discovery of a secular change in the average per-channel talker level of telephone users in this country. Per-channel loading has decreased dramatically since the original loading analyses were performed years ago. This is believed to result from improvements in system quality and more sensitive telephone end instruments both of which permit the average talker to obtain satisfactory performance without speaking loudly. This reduced per-channel loading means more channels can be added to existing systems without overloading them. Taking advantage of these and other easily implementable techniques results in a potential system capacity of over 3000 voice channels per transponder channel.

To improve signal quality and user satisfaction, RCA is implementing



**Fig. 6. Spacecraft structure.** Lightweight modular structure retains proven features of Satcom while accommodating more equipment weight and power.



**Fig. 7. Delta launch configuration.** Spacecraft with new antenna maintained compatibility with the volume limits of the Delta launch vehicle.

adaptive echo cancellers on its private leased channel services. These devices are significantly superior to conventional echo suppressors because they can estimate the echo on a path (via digital signal processing) and then subtract the echo out. Tests performed by the RCA Laboratories indicate that an echo canceller makes a satellite channel perform as well as a terrestrial channel. The adaptive nature of echo cancellers permits them to compensate for a wide variety of circuit conditions, thus overcoming a source of customer resistance to satellite voice channels.

Expanding upon commercial services presently being provided by the Americom system, RCA now offers a wideband data communications service between customer locations called "56 PLUS." It provides for the installation of dedicated five-meter duplex earth stations located at customer offices. These stations are remotely monitored and controlled from a master station in RCA's commercial earth station system. All data carriers use forward error correction with rate 7/8 coding. This technique adds one coding bit for seven (7) information bits and via digital signal

processing at the receive end uses this extra bit to significantly improve error rate performance of the channel. The carrier(s) can be a single wideband data carrier of 56kb/s, or a time-division-multiplexed digital carrier consisting of any combination of lower data rates, or two Delta modulation voice-grade channels with RF transmission via binary phase-shift keying (BPSK). Standard performance for this service is a bit error rate of  $10^{-7}$  at an availability of 99.95 percent. This availability is achieved by full redundancy of all electronic subsystems with automatic

switching to "hot standby" backup units.

In the realm of audio broadcasting and distribution, RCA offers a system capable of providing direct distribution of high-quality audio signals and high-speed data (56-kb/s) to various end users and network affiliates. All incoming subscriber signals are converted to digital format and time-division multiplexed into a single saturating BPSK carrier (the most efficient form of transponder utilization, since no intermodulation products are generated in the spacecraft). Small-aperture, 10-foot, receive-only earth stations installed directly on customer premises receive the signal, and the appropriate portion of the composite carrier is stripped-off and demodulated. The system has greater dynamic range, lower distortion, and superior fidelity than that available on other satellite or terrestrial facilities. Digital transmission is used because its superior immunity to terrestrial microwave systems increases the likelihood of co-locating, without using artificial shielding or other devices, a receive-only earth station on a customer's premises. An important design constraint, which is also satisfied, is that the system not introduce undue levels of interference into adjacent satellite systems, present or future. Digital signal processing techniques are now well developed. They permit the signal to be scrambled to prevent piracy and to enhance system flexibility. Audio bandwidths from 5 kHz to 15 kHz are available.

## Conclusions

Although the total traffic demand of the Americom network will continue to grow rapidly over the next decade, that growth can be accommodated by an expansion and improvement of C-band facilities that will maintain compatibility with existing installations. Taking advantage of the continued launch economy of the Delta vehicle, the second-generation Americom satellite will retain the current 24-channel, polarization reuse frequency plan, but the



**John Keigler**, Manager, Communication Satellite Systems, RCA Astro-Electronics (AE) joined AE as a Systems Engineer working on TIROS ground equipment and secure communications systems using satellite relays. Dr. Keigler led the system design team whose work culminated in the RCA Satcom Program. For this effort he received the David Sarnoff Award for Outstanding Technical Achievement.

Contact him at:  
**RCA Astro-Electronics**  
**Princeton, N.J.**  
**TACNET: 229-2848**

**Walt Braun** is Director of Systems and Advanced Technology Engineering for RCA American Communications, Inc. Employed by RCA since December of 1972, he has been active in all technical aspects of the development of RCA's Domestic Satellite Communications System. Prior to joining RCA, he served with the U.S. Air Force having responsibilities for development and procurement of tactical military communications systems.

Contact him at:  
**RCA Americom**  
**Princeton, N.J.**  
**TACNET: 258-4172**

traffic-capacity per channel will be more than doubled by a combination of improvements in the spacecraft transponder and earth-station equipment. The additional spacecraft weight also permits the incorporation of sufficient propellant, power margin, and component redundancy to ensure a ten-year mission life, thereby

further decreasing the average circuit-cost per year. With an increase in the number of such second-generation satellites plus the several terrestrial installation improvements, the expanded Satcom network will accommodate the growth of the four present traffic centers and introduce new types of services.

# Data communications via satellite

*Data quality on the satellite channels should exceed that on terrestrial channels, and it does, when RCA Americom faces the challenges.*

---

**Abstract:** *The RCA 56 Plus system principally uses small aperture (5-meter) earth stations to provide low-cost customer data networks for the transmission of up to eight channels of 56 kbps digital data. User stations in the contiguous 48 states can communicate with any other user station, similarly located. This paper describes the system.*

---

## Introduction

Satellite systems are leading the way into a challenging new era of communications. They serve governments, commercial businesses and TV broadcasters with data communications, as well as voice and television services. The RCA Americom satellite communications system is one of the specialized common carriers providing data service offerings ranging from teletype traffic to wideband services in excess of 60 megabits per second (Mbps).

Domestic communications satellites concentrate their transmitted power within the boundaries of the United States, thus permitting small and inexpensive earth stations to be used for the economical transmission of data and voice. Currently, stations with antenna apertures as small as 15 feet are licensed by the FCC, and recent deregulation of receive-only earth stations will result in six- and eight-foot-diameter dishes for specialized applications.

The satellite replaces dozens of microwave or cable repeaters, resulting in superior service at a lower cost. Since noise

on terrestrial systems increases with distance, satellite channels are often quieter than long-haul terrestrial channels, with less thermal noise and signal fading. For these reasons, as well as the lower cost, many customers have moved their traditional voice-band data to satellite channels.

## Present wideband services

RCA Americom is presently providing 56 kilobits per second (kbps) or higher-speed data through customer-dedicated earth stations owned and operated by Americom. The following point-to-point data links are currently operational through those stations listed in Table I. These services have been operating with an average yearly availability of approximately 99.9 percent.

Each of these links was designed to the customer's specifications for bit error rate (BER) availability and, in some cases, error-free seconds. This illustrates an important advantage of satellite links: each may be custom designed and is not constrained by the standard Bell hierarchy of data rates or trunk BER objectives.

RCA Americom also provided the first voice and voice-band data links between offshore drilling ships and their Houston headquarters, using small aperture (4.5-meter) satellite terminals mounted on ships engaged in off-shore oil exploration. To compensate for the rolling motion of the ship, the terminals are mounted on four-axis stabilized platforms that use a tracking receiver to maintain pointing using the satellite beacon signal. Despite the extra logistical problems this creates, the digital (32 kbps) satellite link has operated with an

**Table I. Point-to-point data links.**

<i>Link</i>	<i>Bit Rate</i>	<i>Bit Error Rate (BER)</i>
Barking Sands, HA/Goddard Space Flight Center (GSFC), MD	56 kbps	$1 \times 10^{-7}$
Goldstone, CA/GSFC	56 kbps	$1 \times 10^{-7}$
Edwards AFB, CA/GSFC	168/56 kbps	$1 \times 10^{-7}$
Alaska/Suitland, MD	1.3308 Mbps	$1 \times 10^{-6}$
Johnson Space Center, TX/GSFC	1.544 Mbps	$1 \times 10^{-7}$
Jet Propulsion Laboratories, CA/GSFC	56 kbps	$1 \times 10^{-7}$
Goldstone and Alaska/GSFC	15.03 Mbps	$1 \times 10^{-7}$
Wallops Island, VA/Suitland, MD	1.3308 Mbps	$1 \times 10^{-6}$
Sunnyvale AFB, CA/Thule, Greenland	3 Mbps	$1 \times 10^{-7}$
Sunnyvale/Thule	384 kbps	$1 \times 10^{-9}$
GSFC/White Sands, NM	1.544 Mbps	$1 \times 10^{-7}$

availability exceeding 99.9 percent, excluding terrestrial outages in Houston and planned downtime due to ship maneuvers.

## Voice bandwidth data

Voice-band data transmission via satellite is almost indistinguishable from such transmission on terrestrial channels. The same modems may be used in most cases. But in some cases time delays must be compensated for in the initial handshake when contact is initiated. Aside from this, all long-haul voice band data modems up to 9600 bits per second will operate normally on satellite circuits.

Standard Americom voice-band data channels are designed to meet or exceed all Bell C4 (frequency-response and delay-distortion) and D1 (impulse-and-hit) specifications. Typical noise performance can be 2- and 3-dB better, while impulse-and-hit counts average less than one per hour. Therefore, data quality on the satellite channel should exceed that on terrestrial channels in most cases.

## Satellite channel delay

One of the greatest differences between terrestrial and satellite transmission is delay. In order that the satellite stay constantly over the same point on the earth's surface, it must be at an altitude where its orbit is synchronized with the earth's daily revolutions. Since this only occurs at an altitude of 22,300 miles above the equator, this causes an end-to-end delay of about 270 milliseconds, or a round-trip delay of 540 milliseconds. Therefore, a satellite channel inserted into existing systems often increases their response time or decreases their throughput if they are using certain error control techniques that rely on a response from the receiver. Both of these effects are acceptable on many systems, and the cost saving is worthwhile. Nevertheless, a minor modification of the line control mechanisms can often enable the satellite channel to be used without a decrease in efficiency. For example, when polling a multipoint line with multiple terminal locations, the satellite can cause an unacceptable increase in response time. On the other hand, network control procedures designed specifically for satellite channels can give both efficient channel use and a response time fast enough for the use of interactive terminals.

ARQ systems are of two types: stop-and-

wait ARQ and continuous ARQ (Fig. 1).

Stop-and-wait ARQ is the most widely used. After sending a block, the transmitting terminal waits for a positive or negative acknowledgment from the receiving terminal. If the acknowledgment is positive, it sends the next block. If it is negative, it resends the previous block. The decrease in throughput can be minimized in stop-and-wait ARQ protocols used over a satellite channel when the software is modified to optimize the block size to the channel bit rate and BER.

IBM's Bisync protocol, for example, is an ARQ (automatic repeat request) that experiences decreased throughput on a satellite channel. It requests acknowledgment of a data block before it will send the next block of data. Such a system, requiring retransmission of error blocks, has a more serious effect on satellite channels than it does with terrestrial links because of the long propagation time. A sending station has to wait almost 600 milliseconds before it receives an acknowledgment. It must therefore have a buffer large enough to hold many blocks, all awaiting acknowledgment.

Continuous ARQ protocols are well suited to satellite transmission. With continuous ARQ, the transmitting terminal does not wait for an acknowledgment after sending a block; it immediately sends the next block. While the blocks are being transmitted, the stream of acknowledgments is examined by the transmitting terminal. When the transmitting terminal receives a negative

acknowledgment, or fails to receive a positive acknowledgment, it must determine which block was incorrect. The blocks are therefore numbered, often with a 7-bit binary number. The acknowledgment contains the number of the transmitted block it refers to so that the transmitting terminal can identify it.

On failing to receive a positive acknowledgment, the transmitting terminal goes back to the erroneous block, and recommences transmission with that block. This is sometimes referred to as a pull-back scheme. A more efficient technique is to retransmit only the block with the error and not those blocks which follow it. This is referred to as selective repeat ARQ, and is the preferred method for high-bit-rate circuits which have low BERs.

For those customers who do not wish to convert their equipment from stop-and-wait to selective repeat systems, RCA Americom provides Satellite Delay Line Managers (SDLM). The SDLM system requires a unit placed between each terminal and line interface in a point-to-point communications link. These units operate in full duplex mode transmitting or receiving data originating from either terminal. Data blocks from the transmitting station are scanned by the SDLM (transmit side) for the control characters. Each block received causes an immediate pseudo-response from the SDLM, allowing the transmit station to release data blocks in a virtually continuous fashion. The SDLM can recognize all Bisync control characters and respond

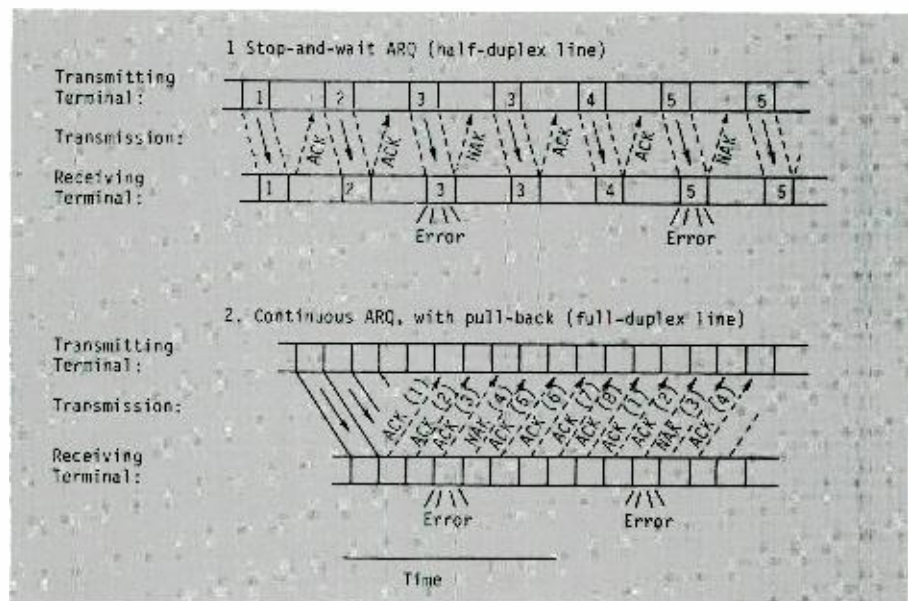


Fig. 1. With stop-and-wait ARQ, much time is spent waiting for acknowledgment. Continuous ARQ rectifies this by permitting blocks to be sent before previous blocks are acknowledged.

to these appropriately. When the data arrive at the receiving SKLM, they are checked for errors. If the data is erroneous, a request for retransmission (ARQ) is initiated. The transmitting SDLM then retransmits the block stored in a buffer. A wait signal is sent to the transmit station whenever this buffer becomes full. This combination, thus, dramatically increases throughput.

## Bit rate variations

When a synchronous line received from a satellite channel interfaces with a terminal or modem that clocks the received satellite data into the terminal with the terminal's internal clock, we must address another problem. Since a satellite is not perfectly stationary, the small Doppler shift due to the satellite's stationkeeping motions causes a dynamic shift in the nominal bit rate received relative to a stable clock. A center-loaded buffer of capacity  $2R\Delta/C$ —where  $R$  is the bit rate,  $\Delta$  is the variation in satellite to earth distance and  $C$  is the speed of light—adequately compensates for this data-rate change. This is required only if the terrestrial line modem cannot accept the receive clock, as when interfacing with the Bell DDS system.

## The 56 Plus service

The RCA commercial wideband data system (the "56 Plus" service) principally uses small aperture (5-meter) user-dedicated earth stations to provide low-cost customer data networks to transmit 56-kbps (or higher) digital data channels. When several of these channels are received at one location or a higher speed service is required, 10- or 11-meter earth stations are usually used. These stations are installed on the customers' premises and operate in the C-band commercial satellite frequencies (5.925- to 6.425-GHz uplink; 3.700- to 4.200-GHz downlink), via the RCA Americom satellite system.

The data are carried by means of single-channel-per-carrier (SCPC) transmission, with a separate carrier for each digitized voice or data channel as opposed to frequency- or time-division multiplex (FDM or TDM) in which many channels are combined onto one carrier. SCPC transmission is one of the most efficient methods of providing service into many light traffic route earth stations. Since it permits easy expansion by adding new carriers, unused capacity does not have to

be provided to allow for expansion capability.

Digital transmission is accomplished by the use of Phase Shift Keying (PSK). This PSK can be either Bi-phase (BPSK) or Quadra-phase (QPSK). For lower data rates, BPSK is used due to its simplicity in implementation and less susceptibility to phase noise. Transmission bandwidth is limited to about 1.5 times the encoded symbol rate as a compromise between signal truncation and minimum adjacent channel spacing.

Although the standard tariffed service offering is at a bit rate of 56 kbps, the versatility of the satellite channel allows any bit rate to be transmitted with almost no additional cost in earth station facilities. Higher data rates would increase the transponder usage, or space segment portion of the monthly costs.

If the user's data requirements consist of several data lines at rates below 56 kbps, a time-division multiplexer can be provided to TDM any combination of lower speed bit streams up to 56 kbps. For example, one combination might include a 1.2-kbps line, three 2.4-kbps lines, a 9.6-kbps line and a voice channel, which would be delta encoded to 32 kbps.

The facilities and equipment employed have been selected to provide a service which will be competitive or better in quality and reliability than Bell DDS 56-kbps channels. This consists of a BER not exceeding 1 in  $10^{-7}$  and an availability to exceed 99.95 percent.

User stations located within the contiguous 48 states can communicate with any other user station, similarly located. Alternatively, users having one or more network nodes in proximity to existing RCA Americom central terminating offices (CTOs) may elect to implement their networks via a combination of dedicated stations and RCA Americom stations, or exclusively via RCA stations. When RCA stations are used, interconnection between the customer and the RCA CTO will be via DDS or other appropriate Telco facilities. User networks can be established on a full-period, half- or full-duplex or simplex dedicated point-to-point or point-to-multipoint basis.

Each of the earth stations used for customer-dedicated data applications has been designed and built to RCA Americom specifications. It is comprised of a 5- or 10-meter antenna, a feed-mounted GaAsFET low-noise amplifier (LNA) (preamplifier), an outdoor communication equipment enclosure which houses the transmitter and frequency conversion equipment, and an

indoor equipment rack containing modems, monitor and control equipment, and test equipment (Fig. 2).

In the transmit direction, data and clock signals obtained from the customer interface are applied to the encoders through a 1: $N$  data switch. When the clock is not provided by the customer's equipment, RCA provides a clock that is either derived from the receive signal or from a local oscillator. The encoder inserts redundant coding information into the incoming data stream and can scramble the incoming data before encoding. The forward-error-correcting (FEC) encoding produces a higher-speed data stream that is applied to the data modulator.

The data modulator is a balanced phase-shift keyer that includes band-limiting intermediate frequency (IF) filtering. An output frequency in the IF range (usually  $70\text{ MHz} \pm 18\text{ MHz}$ ) is selected via a plug-in crystal. The IF output level is set by a level adjustment in each modem.

The IF output of the modulator is amplified and frequency-converted by a high-stability upconverter and traveling-wave tube amplifier to the desired level in the 5925- to 6425-MHz range.

The amplified output is applied to the antenna diplexer through an RF switch and harmonic filter. A parabolic antenna, which uses a Cassegrain-feed subsystem (one which has a convex subreflector), provides the gain to produce the desired uplink effective isotropically radiated power (EIRP).

In the receive direction, the signal in the 3700- to 4200-MHz range is fed from the antenna to the LNA subsystem (usually a GaAsFET preamp in the range of 90  $120^\circ\text{K}$ ). The amplified signal is then applied directly to associated downconverters, which frequency-convert it to the desired level in the 52- to 88-MHz IF range.

The IF signal is applied to the data demodulators through a passive IF divider. Each data demodulator contains a phase-locked PSK demodulator with clock-and-bit-timing recovery circuits. The associated decoder accepts the demodulated bit stream, descrambles and corrects bit errors up to the ability of the Hamming distance in the convolutional code.

The earth station RF equipment is usually configured for 1:1 redundant, hot-standby operation with automatic switchover. The modem subsystem is normally configured in either a 1:1 or 1: $N$  switching arrangement ( $N$  = number of data channels). A monitor and control subsystem usually monitors alarm inputs and remotely controls switching of redun-

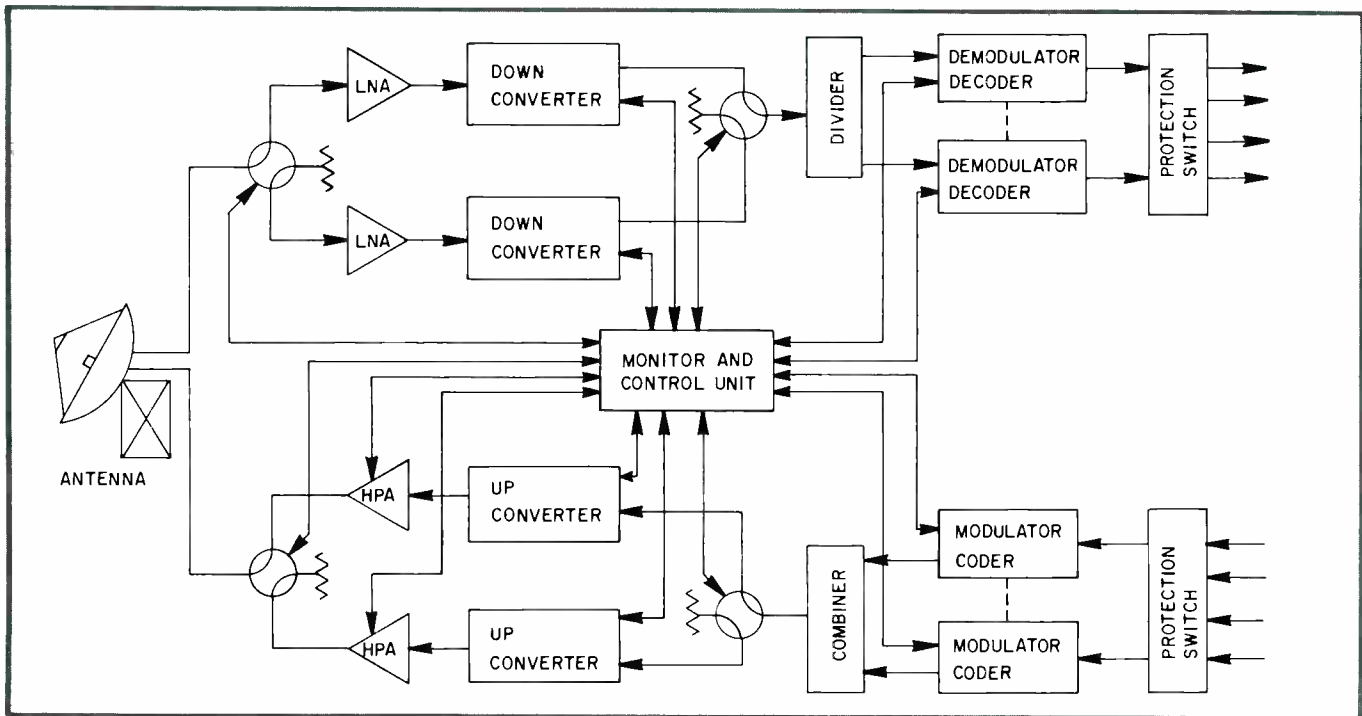


Fig. 2. The redundancy of all critical elements and continuous alarm monitoring are shown in this block diagram of a typical 56-Plus earth station.

tant equipment. It also provides manual override that allows for servicing and periodic maintenance.

A frequency-agile modem is usually provided to back up any failed modem on command from the monitor and control subsystem. This agile modem is normally looped back at IF to allow fault monitoring of the standby modem. When an on-line modulator failure is detected, that modulator is taken off-line, and the agile unit is programmed for its frequency and switched into the circuit.

Sometimes a customer is located in or near one of the major cities served by an RCA Satcom earth station and it is more economical to provide service through RCA's own facilities. RCA presently serves Atlanta, Chicago, Houston, Los Angeles, New York, San Francisco and Philadelphia through Satcom earth stations. With the exception of Atlanta, these earth stations are located outside the metropolitan areas they serve, and are connected via microwave facilities to central terminating offices (CTOs) in or near the business district. In Atlanta the earth station is close to the city and the CTO is co-located with it.

When high-speed data service is provided through an RCA earth station, the customer is connected to the RCA CTO via local leased facilities, such as AT&T's Dataphone digital service (Bell DDS). At the CTO, RCA provides testing facilities to

isolate troubles in the local loop, as well as in RCA Americom's facilities. Group band modems convert the digital data to an analog signal that can be carried to the earth station over RCA Americom's message microwave facility. At the earth station, the analog signal will be converted to digital data once again and connected to a single channel per carrier (SCPC) modem for transmission over the satellite.

When service provided uses RCA Satcom stations at both ends, RCA may interconnect the analog signals from the microwave systems with RCA analog FM/FDM message satellite carriers, thereby eliminating the need for SCPC equipment and group band modems at RCA earth stations. This method will provide the same high quality service.

### Forward error correction (FEC)

As with terrestrial system, bit errors in satellite transmission are caused by noise. The noise on space links is mainly Gaussian white noise that tends to damage the transmitted symbols at random. The damage to one symbol is largely independent of the damage to others. A symbol is the encoded and modulated data bit.

While this noise can be reduced by increasing the carrier power (which also increases the space segment costs

proportionately) and/or increasing the earth station antenna size, it is more economical to correct the occasional bit errors through a process known as forward error correction (FEC).

While FEC has a higher probability of transmitting bit errors than ARQ systems, there is no adverse effect from satellite delay times. Since some errors remain uncorrected, it occasionally needs to be backed up by the use of ARQ for transmission of critical data, which cannot tolerate error rates higher than one in  $10^9$  bits.

There are two measures of the effectiveness of an error-correcting code. First, how much does it improve the BER? And second, what is the proportion of overhead bits needed? The number of bits of information received per bit of transmission is called the rate of a code. In a 3/4 rate convolutional code, three-quarters of the bits transmitted are information and the rest are used for error detection and correction.

The BER improvement is a function of two factors: the coding rate and the complexity of the code (referred to as constraint length). An economical code for wideband data is rate 7/8 convolutional encoding of constraint length seven with threshold, or "hard decision" decoding with better than three orders of magnitude BER improvement when the uncoded BER exceeds  $10^{-4}$ . As the coding rate decreases (rate 3/4 and 1/2 are also common FEC

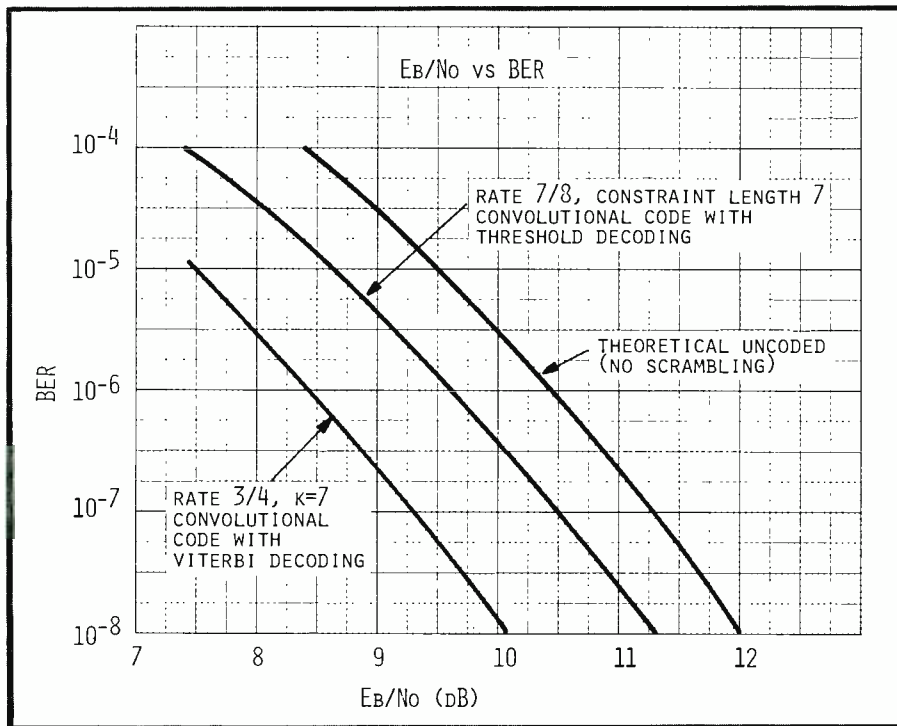


Fig. 3. Various types of forward-error-correction coding provide different levels of performance.

rates) the coding gain increases, but the bandwidth required for the transmission increases proportionately, limiting the number of channels that can fit into a transponder that has limited bandwidth.

Another more powerful FEC technique is the "soft decision" or Viterbi decoding. This technique uses probability to decide

whether a bit is a one or a zero. The method provides a coding gain of about 2 dB over threshold decoding. But the cost of such decoders is usually substantial and is only justifiable for high-bit-rate data or in cases where transponder power is very limited. Figure 3 shows a comparison of various FEC techniques.

## Data transmission using TDMA

A highly efficient method of transmitting large amounts of data by satellite is time-division multiple-access (TDMA) transmission—one of two basic forms of multiple access. The simplest form is frequency division multiple access (FDMA) transmission. In FDMA, carriers from each earth station occupy distinct frequency bands within the transponder. Since multiple signals of different frequencies are being added in the transponder, gain must be relatively linear to minimize intermodulation interference. This is accomplished by operating the transponder in a backed off mode, in which, the power coming out of the transponder is considerably lower than the maximum possible output power.

TDMA is a more advanced system. In a TDMA system, each earth station transmits bursts of digitized voice or data that pass sequentially at the same frequency through the transponder (Fig. 4). Since the transponder carries one burst at a time, each burst can use the full power and bandwidth of the transponder. These bursts are dynamically synchronized to a reference signal sent from a master station.

The advantages of saturating the transponder with each burst is that it eliminates the normal transponder output back off (typically 6 dB) that must be allocated to optimize intermodulation product interference in a typical FDMA transponder. Intermodulation (IM) products normally require the power level of each carrier in a transponder to be increased to attain the same carrier-to-noise objective as would be achieved without any intermodulation products. This effect is also eliminated by TDMA since only one carrier at a time accesses the transponder and the IM products are eliminated. Overall, this results in an effective increase of 7 to 8 dB in the amount of power available from any given transponder.

## Terminal operation

Data circuits are time division multiplexed into T1 (1.544-Mbps) multiples. Timing signals are sent from the TDM to interface modules so that they transmit their data at the proper times. A multiplexer with compression buffers controls all transmit timing such that the bursts from the various interface modules are collected properly and formed into a TDMA burst. In addition, this multiplexer sends gating signals

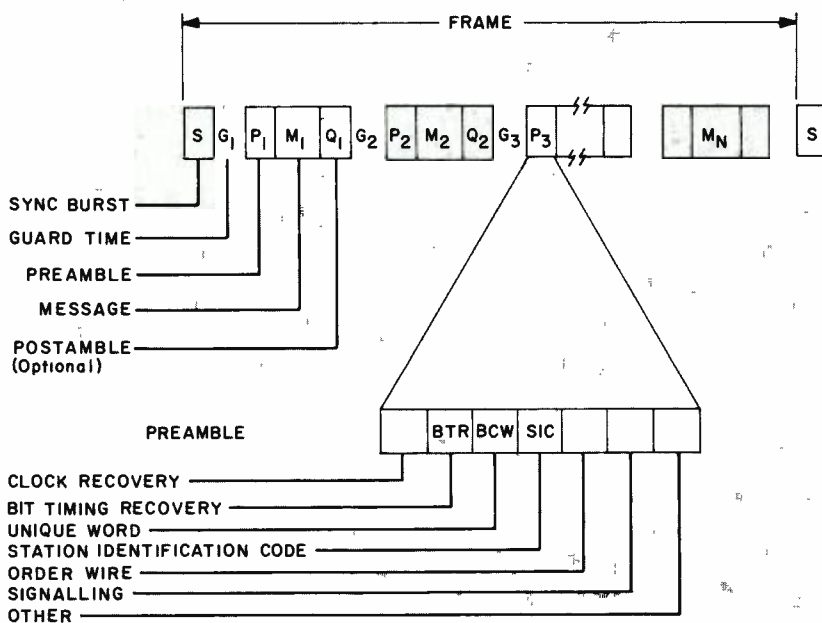


Fig. 4. Overhead in a time-division multiple-access (TDMA) system consists of bits used to label and control the blocks, as well as guard time between them.



to the preamble generator and scrambler, so that they generate their data for the burst at the proper time. The demultiplexer and expansion buffer perform the inverse functions. Information from each interface module is called a sub-burst. Burst formats are programmable, usually by changing a read-only memory (ROM).

The burst synchronizes the above equipment and the preamble generation/detection units. At the transmit side, the various units run off the master clock oscillator. At the receive side, the equipment runs off the burst clock provided by the four-phase PSK demodulator. Continuous low-rate clocks (for example, at 1.544 MHz) are derived in the expansion memory/destuffing logic for each low rate output bit stream. A typical frame has two sync bursts and up to forty data bursts. The sync burst is a burst of signals emitted by a station called the reference station, which contains only that information required by the other stations to derive the precise time reference for the location of their unique words. The position of the other bursts in the frame is slaved to the sync bursts. Two sync bursts are provided so that if one reference station fails, at least one sync burst will always be in the frame. This avoids problems caused by reference station failures.

Burst lengths and burst positions can be dynamically assigned or can be fixed in normal operation but may be occasionally changed manually. Each burst is assigned a position within the frame that takes into account the guard time between any two adjacent bursts.

## Piggyback data on TV distribution

The largest of RCA Americom's current markets is the cable television (CATV) program distribution service, presently being furnished to a number of entertainment and religious networks. Today, twenty

**Thompson Mitchell** is a Senior Member of the Engineering Staff in the Systems Engineering Group. He is responsible for the system design and link performance specifications for all commercial service proposals and capital projects. He has performed the system design for a video taping and editing system, a system of small aperture earth stations for the transmission of 56-kbps data, and a major upgrade of RCA's private-leased channel system.

Contact him at:  
**RCA Americom**  
**Princeton, N.J.**  
**TACNET: 258-4181**

**Richard Langhans** is Manager of Systems Engineering at RCA Americom. He is responsible for the transmission standards and system design of all Americom services. He is also responsible for the technical content of all proposals involving voice-grade, wideband data and video services via the RCA Americom satellite system. He has over 13 years of experience in analog avionics circuit design and satellite communications.

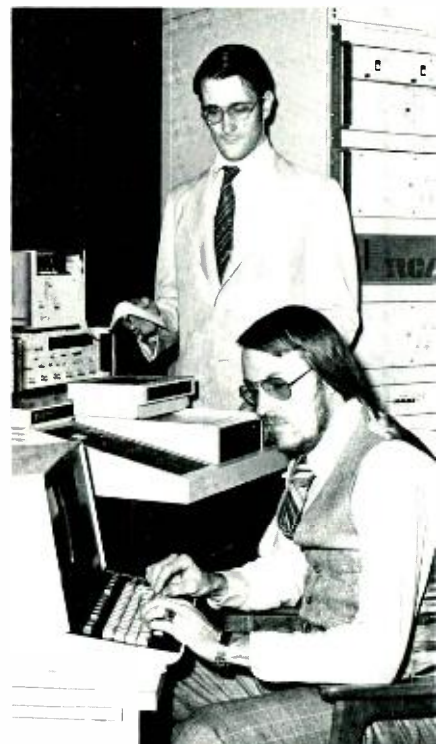
Contact him at:  
**RCA Americom**  
**Princeton, N.J.**  
**TACNET: 258-4174**

channels of video are being distributed to the CATV industry on RCA's Satcom 1 satellite.

This distribution system has the potential for carrying large amounts of data from a central point to a vast number of receiving locations in areas served by CATV throughout the United States and Canada.

To accomplish this, the data must be combined with the TV signal at its originating point and separated from it at the CATV head end or customer's premise without degrading the quality of the TV signal. This can be done several ways.

One method is to add a digital subcarrier to the TV signal. This signal consists of a carrier that is frequency-modulated by a baseband consisting of a video (picture) signal from dc to 4.2 MHz and an audio (sound) subcarrier at 6.8 MHz. A QPSK



digital subcarrier carrying up to 1.544 Mbps can be added at 5.5 MHz without noticeably degrading either the video or audio signals. This subcarrier can be demodulated at the CATV head end, and the data can be sent to one or more customers, either via leased lines or via the CATV cable.

Another method is to insert the data directly into the video signal. This data occupies some of the otherwise blank lines in the vertical blanking interval between the individual frames of the TV picture. One advantage of this method is that the data is fed onto the cable as part of the video signal, that is, no processing is required at the CATV head end. This system can be used to distribute subtitles for the deaf, special news or weather information, or any other signal to be distributed to private receivers.

# “Two-for-one” microwave system for video

*The two-for-one radio doubles the video channel capacity per unit bandwidth of a video microwave system.*

---

**Abstract:** *The authors examine the problems, constraints and solutions involved in the development and installation of the subject 2:1 radio, along with the FCC regulations that influenced both its development and use in Americom's system.*

---

RCA American Communications (RCA Americom) is an operating company of the RCA Corporation, formed in 1976. It is a domestic common carrier and as such is both regulated by the Federal Communications Commission (FCC) and authorized to provide tariffed point-to-point communications services via satellite within the territorial United States.

RCA Americom has four major business groups, each responsible for a distinct market. Government Communications Services provides all communications services to federal, state and local government agencies; Commercial Communications Services provides private leased telephony and data services to commercial customers; Alascom Services provides satellite communication services to the Alascom Inc., which handles communications within the state of Alaska and between Alaska and the rest of the United States, and Video and Audio Services provides television and audio services to commercial customers including the broadcast and cable television industries.

To support these business areas, RCA Americom owns and operates two geosynchronous satellites (a three-satellite system is planned for 1981), a number of customer-dedicated earth stations and a

network of commercial earth stations with associated terrestrial microwave radio links.

Figure 1 shows the New York commercial system. This system includes the Vernon Valley earth station some 60 miles outside New York City and a terrestrial microwave radio link to the central communications office at 60 Broad Street in Manhattan. The remote location of the earth station is dictated by a combination of the sharing of frequency bands between satellite and terrestrial users, and the general frequency congestion which exists in and around New York City (and most other major cities).

This same frequency congestion that results in the remote location of the earth station makes the acquisition and expansion of a terrestrial microwave radio link to serve the earth station very difficult.

The two-for-one (2:1) video radio was developed for application to the New York terrestrial microwave link to expand its

capacity in an environment where additional conventional channels were not available. Its objective was to provide two video signals per microwave channel. The quality of each was to be equal to that of the conventional system, which provides only one signal. This was to be done in such a way as to conform to all the existing rules and regulations of the FCC, to ensure a licensable, resultant system.

## Design constraints and the FCC

To ensure that the 2:1 radio would be acceptable for use on a regulated domestic common-carrier terrestrial microwave system, the rules and regulations had to be considered as part of the design criteria. These rules govern both the design and operation of terrestrial microwave radio equipment, and the licensing of point-to-point terrestrial microwave stations. The

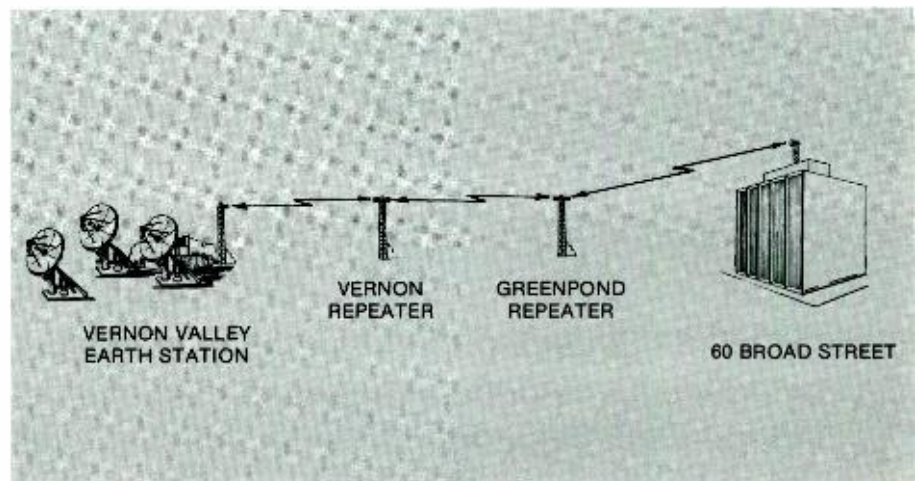


Fig. 1. New York/Vernon Valley radio link.

Reprint RE-26-3-5  
Final manuscript received Oct. 21, 1980.

constraints defined by these rules and regulations\* were as follows:

- The 2:1 radio must operate within the normally allocated channel bandwidth and meet all FCC out-of-band emission requirements.
- The 2:1 radio must be able to operate with the same in-band restrictions as the existing conventional radios used on the New York system.
- The equipment used must be "type accepted" by the FCC or designed to pass FCC type-acceptance tests.
- The 2:1 radio must be able to accept the same interference levels from other interfering radios as the existing conventional video radios.
- The 2:1 radio must be accepted by other common carriers as producing interference phenomena that are not significantly more harmful than the existing conventional radios.

Part 21 of the FCC Rules and Regulations completely defines the first three constraints. The fourth and fifth items establish criteria for acceptable levels of interference between domestic common-carrier systems.

Neither these interference criteria nor their methods for calculation are directly specified by the FCC. Instead, the FCC has established a coordination procedure as part of the licensing process for both terrestrial radio stations and satellite earth stations. In the paragraphs that follow the methods by which the coordination procedure is used to establish interference criteria will be discussed.

The coordination procedure requires that a prior notice containing the following information be sent to all common carriers who could be affected by the proposed system.

- Technical characteristics, including radiation levels, modulation techniques, antenna pattern and site location.
- Interference criteria for the maximum allowable interference levels into the proposed system.
- Radio-frequency interference (RFI) analysis demonstrating that the coordinating system does not produce interference levels into other coordinated stations in excess of the interference criteria stated in their coordination.
- RFI analysis demonstrating that no coordinated system will produce in-

terference levels in excess of the stated criteria for the coordinating system.

The affected common carriers have 30 days to respond to a prior coordination notice after which it is assumed that they agree with the information in the coordination notice. If no response is received within 30 days, the subject station is successfully coordinated. If one or more of the common carriers disagree, they respond by letter indicating the reasons for their disagreement.

These disagreements must be resolved before a station can be successfully coordinated and eligible to receive an operational license.

The procedures for calculating the interference levels caused by one common carrier system into another are defined by the FCC for the coordination process. No procedure is established, however, for determining the interference criteria. These criteria are specified instead in the coordination notice by the coordinating carrier based on his own calculations and judgments. The FCC relies on an attitude of cooperation by necessity to prevent the carriers from establishing unreasonable criteria: This attitude normally prevails since each carrier needs the cooperation of all other carriers to coordinate its desired systems, and any carrier can easily justify reciprocation of unreasonable criteria.

Returning to the list of design constraints presented previously, you can see that it is difficult to define constraints concerning interference criteria since there are no rules as to what constitutes acceptable interference levels.

For the fourth constraint, involving interference levels into the subject radio system, the criteria are established by RCA Americom and therefore pose no problem. The fifth constraint, however, is a different matter since there is no way to be sure exactly what interference criteria would be established by the other common carriers given any specific set of characteristics for the 2:1 radio.

To proceed with the development, RCA Americom had to look at the 2:1 radio using their own procedures for determining acceptable interference levels. It was assumed that these results would reflect those which would be determined by the other common carriers.

As the discussion proceeds, it will be shown how the design objectives were met with the listed constraints. The problems caused by the undefined interference criteria will be highlighted in the section on installation of the 2:1 radio.

## Approaches

A number of established 2:1 techniques currently in use could meet the objectives and constraints previously discussed. They may be divided into single-carrier/multicarrier and frequency-division/time-division groups. A carrier can be modulated by one or many independent signal sources by frequency-division multiplexing (FDM) where each of the independent signals are given a different frequency slot within the baseband. The composite FDM signal can then modulate the carrier. When frequency modulation (FM) is used, the system is referred to as FDM/FM.

Time-division-multiplex (TDM) systems require sampling the input channels at the Nyquist rate or higher. These samples are then sequentially combined. The carrier is modulated by the resultant composite waveform.

Multicarrier systems are also used within a given bandwidth. A single input waveform may modulate each carrier (SCPC, single channel per carrier) or a number of input signals can be combined (FDM or TDM) to modulate any of the carriers.

A further consideration is whether the transmission is analog or digital. Usually digital transmission is incorporated when TDM is used. The output binary data stream phase modulates the carrier using a specially-developed modulator/demodulator or modem. (The term modem is used to describe any modulator and demodulator pair.)

A number of methods exist that could provide a doubling of video capacity. Of the various techniques considered, cost of implementation, as well as the technical performance, influenced the final selection.

Systems that were already in existence and could be conveniently implemented were the primary candidates for investigation. Work done by others in the same general area but directed primarily toward satellite communications, as well as commercially available equipment that could be used in either terrestrial or satellite communications, were considered.

## Baseband diplexing

One of the first methods to be explored was made possible by commercially available equipment designed to carry one TV channel and approximately 900 voice channels and made available through the efforts of D. Fremont of RCA Americom.

\*This discussion presents the engineering problems encountered and does not intend to offer any legal opinion.

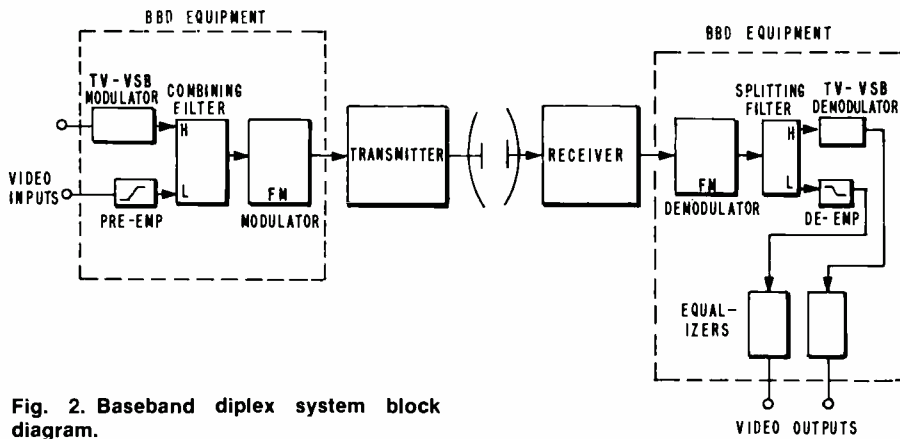


Fig. 2. Baseband duplex system block diagram.

The system used FDM with the voice channels occupying the baseband portion, 0 to 5.5 MHz, while the TV signal (after translation) made use of the 6.8- to 12.0-MHz portion of the baseband. The video signal was translated by vestigial sideband amplitude modulation of a 6.8-MHz carrier.

Figure 2 shows a block diagram of the video-over-voice baseband diplexing system as modified for use in the video-over-video configuration. By replacing the intended 900-voice-channel allocation by a baseband video signal, it was possible to carry two TV signals in a baseband of 12-MHz. This composite signal was then used to FM modulate the single carrier in an assigned operating band. No other modification of existing equipment is required when this system is used.

At the transmitter end of the system, the two channels were adjusted so as to produce the same output signal-to-noise ratio ( $S/N$ ) at the receiver. The lower channel video was pre-emphasized in the usual manner and the upper channel was operated without pre-emphasis. The upper channel deviation was adjusted to 4 MHz (the standard value). Because of the triangular noise voltage spectrum at the

output of an FM demodulator, the noise in this upper channel was 16 dB greater than in the lower channel. In other words, the  $S/N$  of the upper channel is 16 dB lower than standard. Thus, the two equal  $S/N$  signals were 16 dB below the  $S/N$  of a standard single channel operating at a  $\Delta f$  of 4 MHz.

At the receiving end, the demodulated signal is applied to a filter which separates the low and the high channel video signals. The high channel is translated back to baseband and the low channel is de-emphasized and amplified. Both signals are passed through a video equalizer which is used to compensate for the group delay distortion introduced by the combining and separating filters.

The baseband diplexing system was tested over a simulated three-hop microwave link in the lab. The peak deviation was set at 4 MHz for the high channel. In order to avoid luminance crosstalk from the high channel to the low channel, the modems have to be very linear and must accept the 12-MHz baseband signal. This luminance crosstalk is due only to the nonlinearity of the modems and is not affected by the number of hops in the microwave link. The use of typical

microwave modems not designed to handle a 12-MHz baseband resulted in a signal-to-crosstalk ratio of 17 dB in the low channel. The use of a laboratory modem, which was wideband (15 MHz) and very linear, resulted in a signal-to-crosstalk ratio of about 40 dB when equalized for radio-frequency (rf) group delay and adjusted for minimum distortion.

Some experiments were carried out to determine how the audio portion of the signal could be carried. Appropriately placed subcarriers were added (4.9 MHz in the low channel and 5.5 MHz in the upper channel) at locations and amplitudes to minimize crosstalk. The  $S/N$  is proportional to the carrier-to-noise ratio ( $C/N$ ) and, with 0-dB fade, the measured value was 63 dB, peak. A technique which placed the audio in the horizontal sync (two 10-bit samples per sync pulse) resulted in an  $S/N$  of 71 dB with carrier fades up to 35 dB.

The linearity constraint on the modulators and demodulators for acceptable crosstalk, the 16-dB reduction in  $S/N$ , and the high cost of the equipment were the reasons this system was shelved.

## Digital TDM

Digital techniques are advancing rapidly and, in the area of TV transmission, considerable effort has been expended. A system developed, off-shore, that can handle a number of video signals simultaneously—and primarily directed toward satellite applications—was evaluated. The maximum output bit rate was 64 Mbps and was achieved when two or three video signals were multiplexed together. A single channel could operate at up to 32 Mbps and at that rate the picture quality was very good, even in action shots. When 22 Mbps, or slower, bit rates were used, stop-action was sometimes noticed. This resulted from the buffer overflow.

The system incorporates an 8-bit per sample, 10.7-MHz sampling rate differential-pulse-code-modulation (DPCM)

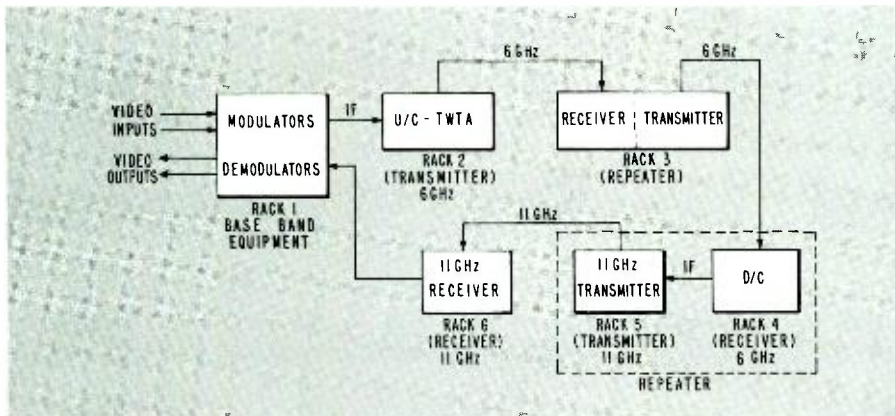


Fig. 3. Experimental three-hop microwave radio system.

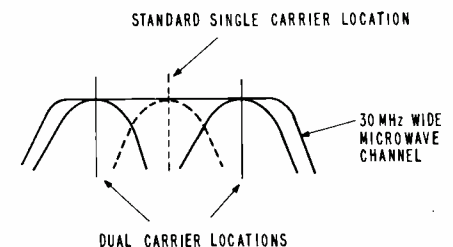


Fig. 4. Carrier locations for single-carrier and dual-carrier approaches.

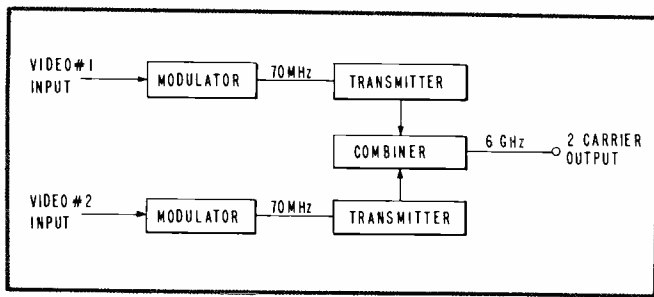


Fig. 5. Implementation of two-carrier system at transmitter site.

technique. It uses a frame of storage and sends only difference information via a buffer. Pictures with many changes frame-to-frame require more data to be transmitted and may eventually fill the buffer. At that point the picture is retransmitted and the stop-action momentarily occurs.

The 64 Mbps data rate requires about 38 MHz of bandwidth when using a QPSK (quadrature phase-shift-keying) modem. For satellite applications this is probably acceptable. A microwave channel typically has 30 MHz of bandwidth available and would be restricted to a 50-Mbps data rate to properly confine the rf spectrum. Thus, for two video bit streams, 25 Mbps would be required for each. Pictures sent at this data rate exhibit an artifacts level in high-action shots that could be objectionable.

The system did have a feature which could help in this regard. An adaptive data rate (dependent on the demand) was possible to allow a higher data rate on the "action" picture and a reduced data rate on the slower changing "still" picture. This feature would reduce the frequency of occurrence of the stop-action artifacts except when both sources require high data rates simultaneously.

When equipment costs are reduced and further improvements in adaptivity are incorporated, digital systems for TV transmission will become more common. At this time, however, a lower-cost analog technique seems more appropriate.

## Two-carrier analog system—the system selected

A two-carrier approach had been used for satellite TV transmission to Alaska on RCA Americom's system.<sup>1</sup> The constraints for microwave radio are somewhat different and an experimental program was initiated to determine the optimum configuration and operating parameters for that service. To simulate the actual field conditions, RCA Americom provided a

complete three-hop microwave radio system (operating at 6 and 11 GHz) as shown in Fig. 3. Path loss was simulated by fixed attenuators in series with the interconnecting waveguides (variable attenuators were used to simulate fades).

Figure 4 shows the basic premise of the two-carrier approach. Rather than a single carrier centered in the operating bandwidth, two carriers are used, each offset from the center, as indicated. The dashed lines in the figure represent the standard carrier location and its modulation spectrum whereas the solid lines indicate the carrier locations and their associated spectra when two carriers are employed. In Fig. 5, which is a block diagram for the three-hop experimental setup of Fig. 3, each of the transmitters consist of an upconverter and the power-output traveling-wave tube-amplifier (TWTA). The upconverter, which is crystal-controlled, converts the 70-MHz input intermediate frequency (IF) signal to the assigned output frequency (in this case, the 6-GHz band). The upconverter has sufficient output to drive the TWTA to its saturated output power rating of 10 W. By simply changing the crystal frequency in each upconverter, the desired carrier offset for the two carriers is obtained. Once that is accomplished, the outputs of the two upconverters could be summed and used to drive a single TWTA. This is not done here.

A TWTA, when operated at its maximum output power, is nonlinear and, therefore, produces unwanted intermodulation products when more than one carrier is present at its input. Also, the TWTA exhibits amplitude-modulation to pulse-modulation (AM to PM) conversion when operated near saturation and can cause visible crosstalk. Figures 6 and 7 show two curves based on measurements made on a TWTA and indicate the input-output power relationship as well as the

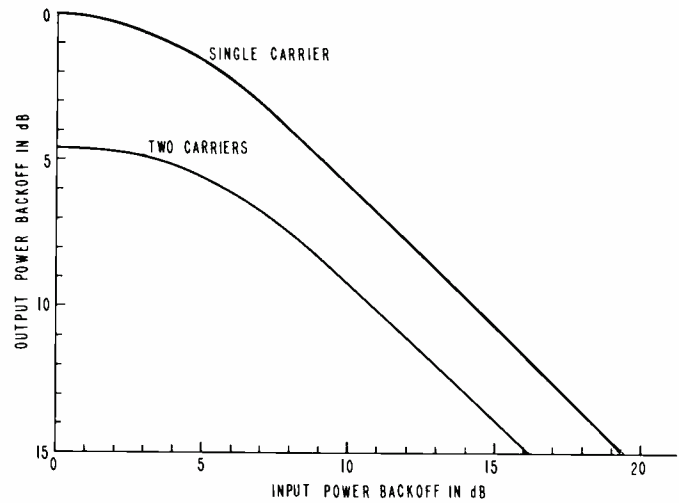


Fig. 6. TWTA output power versus input power characteristic.

output phase versus input power characteristic.

To reduce the effects caused by these characteristics, the input signals to the TWTA are attenuated, moving the operating point into the more linear region of the tube. The disadvantage of this solution is the resulting reduction of output carrier power. While in some cases the power reduction may be acceptable, it was unacceptable for the intended path of the experiment. The path simulated was New York City to Green Pond, New Jersey, a distance of 32 miles.

For this case, the preferred implementation was to use two TWTAs—one for each carrier—each operating at full saturated power. Their outputs are then summed in a waveguide hybrid. The summing operation introduces a 3-dB loss per carrier. By comparison, when using a single backed-off tube, the loss is at least 4.5 dB and can be up to 11 dB for some conditions. Shorter hops, that normally require the TWTA drive to be reduced to prevent receiver overload, would not need the second TWTA.

The repeater sites can take on somewhat different configurations depending on the power output requirements. Figure 8 is a block diagram of a dual-channel implementation providing maximum output power but requiring substantial added equipment. Note that the two carriers are separated by filtering and are treated independently through the repeater. The two TWTA amplifiers are operated at saturation and their outputs summed at rf. This is similar to the configuration at the transmitter site explained above.

For cases where some output power reduction is tolerable, consistent with the desired *S/N* versus availability, there is a simpler preferred mode to be employed at the repeaters. Figure 9 is the block diagram of the so-called single-channel configura-

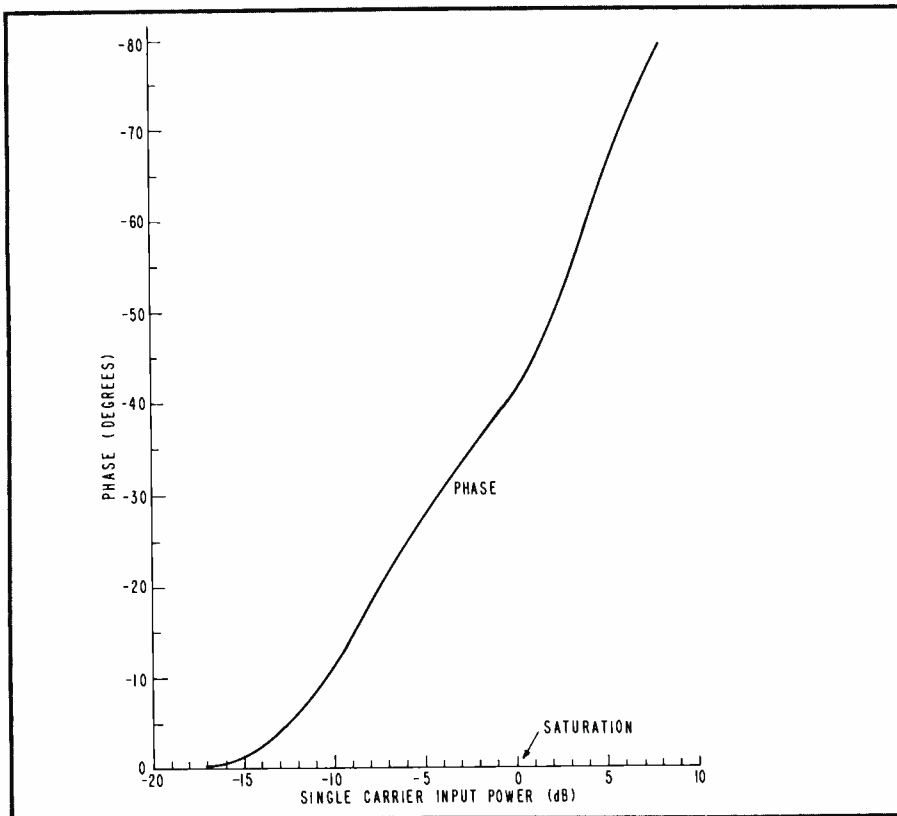


Fig. 7. TWTA output phase versus input power characteristic.

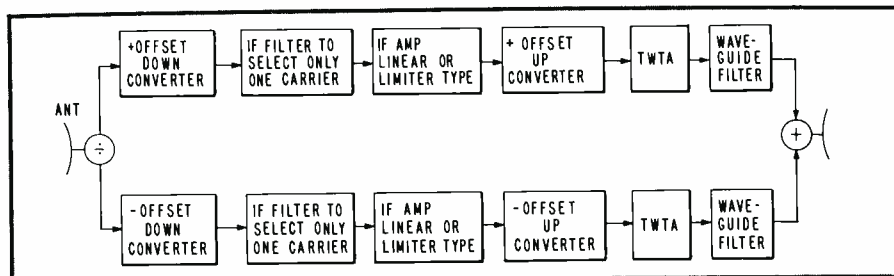


Fig. 8. Dual channel two-carrier repeater configuration.

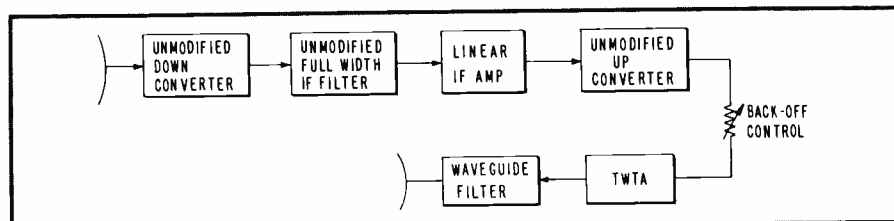


Fig. 9. Single channel two-carrier repeater configuration.

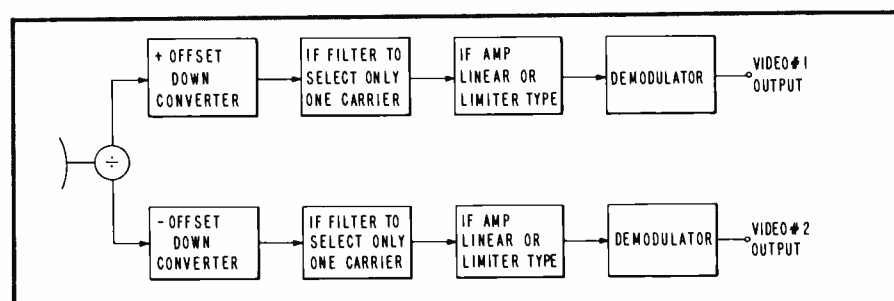


Fig. 10. Implementation of two-carrier system at receiver site.

tion that was actually used in the field implementation of this system. The differences between this arrangement and the original unmodified equipment are extremely minor.

Regardless of the configuration of transmitter (the origination point at New York) and the repeaters, the receiver (the termination point) is implemented as shown in Fig. 10. Two downconverters are used, each offset +8 MHz and -8 MHz, respectively, from the band center. In conjunction with standard 70-MHz IF filters, of appropriate bandwidth, the two FM video carriers are separated. From that point, each of the respective signals are amplified and then demodulated using standard 70-MHz microwave-radio FM demodulators.

In its simplest version then, the 2:1 system requires one extra modulator and up-converter at the transmitter and one extra demodulator, filter, and down-converter at the receiver. For the RCA Americom application, an extra TWTA and rf-summing network was required at the transmitter end of the link.

## System optimization

Three important operating parameters must be determined to optimize system performance. They are: (1) carrier spacing; (2) frequency deviation; and (3) magnitude of power backoffs. Since output signal-to-noise ratio is proportional to received power and to the square of frequency deviation, items 2 and 3 should be maximized and minimized respectively. The optimum carrier spacing is determined by items 2 and 3 as well as signal distortion considerations. The three parameters are mutually dependent but can be optimized experimentally.

In addition to video distortion and S/N considerations within the operating band, there are other constraints that place limits on these parameters. One, mentioned earlier, has to do with the assigned bandwidth and the required bandwidth of an FM signal. There are FCC rules regarding out-of-band radiation levels. One such rule states, "99 percent of the signal spectrum power should be confined to the assigned bandwidth." There are other specifications regarding spurious signal levels caused by image frequencies or intermodulation products. The latter specification is given as a "mask," an example of which is shown in Fig. 11. Armed with this information as well as the knowledge of allowable video distortion

limits<sup>2</sup> and together with some actual equipment, complete with bandpass filters, the process of optimization began.

The frequencies of the two upconverters in the transmitter were made variable by the addition of external signal generators. This was done as well for the receiver's down-converters. Level-setting attenuators were added at the repeaters to allow adjustment of power backoff. To correspond to different deviations, IF filters of various bandwidths were on hand (these filters are used at the receive end of the system, as shown in Fig. 10).

The use of IF filters in the transmitter, in an attempt to reduce the bandwidth of the radiated spectrum, proved to be ineffective when using the maximum possible  $\Delta f$ . Associated with the IF filters are added amplitude and nonlinear phase characteristics which act on the higher deviation components of the input signal. When passed through TWTA having AM to PM conversion, the result is spectrum spreading to a degree that produces essentially the same radiated bandwidth as in the unfiltered case. The magnitude of this known effect was determined experimentally. When filters are cascaded, the resultant total amplitude and phase characteristic require a reduction in  $\Delta f$  to maintain the quality of the video distortion parameters; unfortunately, this leads to reduced  $S/N$  (or availability). It is therefore desirable to use a minimum of filters. In the described system, only one IF filter per video channel is used.

The first experiment was done on the repeaters to determine the backoff necessary to keep out-of-band intermodulation (IM) products within the FCC specifications. Carrier-level control is usually provided in one of two ways. Some microwave radio repeaters use limiting (clipping) stages in their IF amplifiers. Such amplifiers are generators of IM products and often have poor AM to PM conversion which is a source of cross modulation. Other repeaters use linear automatic-gain-control (AGC) amplifiers; these have essentially none of the above-mentioned problems.

Since this implementation has the two carriers common to all elements of the repeater (downconverter, IF amplifier, up-converter and TWTA), they all should be operated in a linear mode. Those microwave radio repeaters using clippers must have them replaced by linear AGC amplifiers. When the "dual" repeater is used, as shown in Fig. 8 (for reasons of higher output power), clippers may be used. Because the individual carriers are

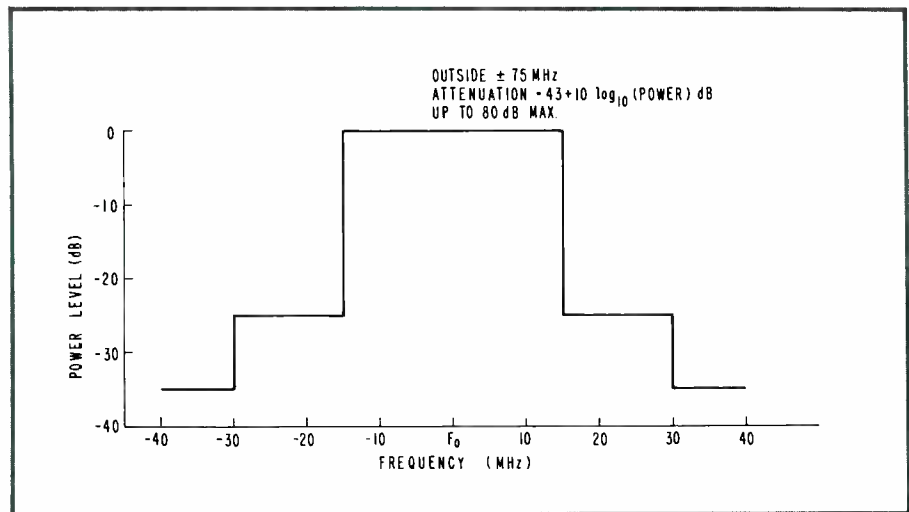


Fig. 11. FCC mask for spurious response in the 6-GHz band.

separated by IF filters prior to the non-linearity, there will be no production of unwanted products. As explained before, the use of additional IF filters requires reduced deviation and therefore tends to eliminate any advantage derived from higher output power. The reduction in drive to the TWTA necessary to keep the IM products within specification depends on the channel filters following the TWTA as well as the tube itself. Figure 12 is a spectral distribution of IM products generated at the broadly tuned output of a saturated TWTA with two equal amplitude-input signals.

Due to the nonlinearity of the TWTA at saturation, the magnitude of the two desired output carriers are each about 4.6 dB (not 3 dB) below the single-carrier saturated output. The characteristics of output filters vary from manufacturer-to-manufacturer as do TWTAs, resulting in

the required output backoffs to be tailored to the particular equipment being used. Typical total output backoff requirements found in the laboratory were 5.6 to 11 dB per carrier relative to single saturated carrier; that is to say, there is an additional 1.0- to 6.4-dB reduction from the not-backed-off loss of 4.6 dB per carrier.

The spacing of the two carriers is initially set by locating each carrier half way from the center to one of the band edges (Fig. 4). For a 30-MHz wide channel, the placement of the carriers is, therefore,  $\pm 7.5$  MHz from band center. The intermodulation products are then located  $\pm 22.5$  MHz from band center (the 3rd-order IM),  $\pm 37.5$  MHz (5th order), etc. The spacing of the IM products is equal to the spacing of the two carriers. The 3rd-order products, when compared to higher-order products, are the most critical in that they are the largest, but also are the least affected by the output

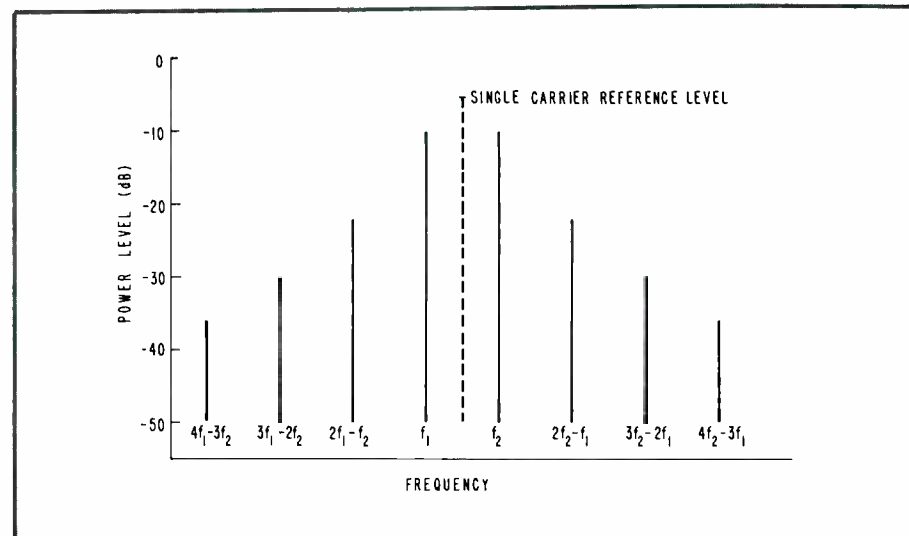


Fig. 12. Two-tone intermodulation spectrum of TWTA operating at saturation.

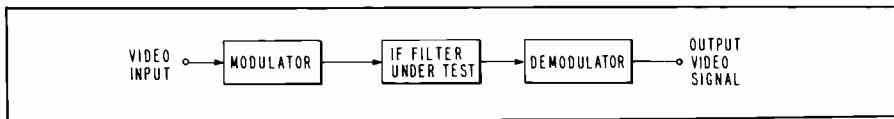


Fig. 13. Test set-up for filter experiments.

Distortion Parameter	NTC Specifications	* Measurement
Chrom-Lum Delay	$\leq 75$ ns	6 ns
Chrom-Lum Gain	$\pm 6\%$	-6%
Field Time Distortion	$\leq 4\%$	< 1%
Line Time Distortion	$\leq 4\%$	< 1%
Short Time Distortion	-6%	-1%
Luminance Nonlinearity	$\leq 10\%$	< 1%
Gain/Frequency Distortion	+69%/-10%	-10%
Differential Gain	$\leq 15\%$	< .5%
Differential Phase	$\leq 5^\circ$	2.6°
Chrominance Nonlinearity	$\pm 10\%$	-1.3%
Chrominance Phase Nonlinearity	$\leq 5^\circ$	< 1°
Chrom-Lum Intermod	$\leq 3\%$	<< 19%

\*  $\Delta f = 4$ -MHz  
IF bandwidth = 16-MHz

Fig. 14. NTC 7 and measured video distortion parameters.

channel filter. In this sense, increased carrier spacing reduces 3rd-order IM due to the resulting increased attenuation of the output filter. Other factors, however, have a stronger influence on carrier spacing.

As stated before, the frequency deviation ( $\Delta f$ ) of an FM system affects the resultant signal-to-noise ratio as  $f^2$ . There are limits on how large  $\Delta f$  can become. Assuming that each of the two carriers (plus sidebands) occupies half of the original 30-MHz bandwidth and that the Carson rule applies then, with  $BW = 15$  MHz and  $f_m = 4.2$  MHz ( $f_m$  is the maximum modulation

frequency and for the NTSC system, is 4.2 MHz), solving for  $\Delta f$  yields 3.3 MHz, peak. Deviation experiments were performed using 10-, 12-, and 16-MHz 1F filters. First, the maximum allowable deviation through each filter was determined using the setup as shown in Fig. 13. By increasing the deviation until accepted standards of video distortion are just exceeded in the ideal test setup, an absolute maximum deviation is obtained for each filter. Typical values are:  $\Delta f = 2.0$  MHz for the 10-MHz filter,  $\Delta f = 3.0$  MHz for the 12-MHz filter and  $\Delta f = 4.0$  MHz for

the 16-MHz filter. A list of video distortion parameters and their broadcast quality limits is given in Fig. 14. Some video distribution services have less stringent requirements and would permit greater deviations. The trade-off is increased  $S/N$  at the expense of video distortions.

For each of the three filters, a series of measurements were made to observe the effects of carrier spacing. From a crosstalk point of view, it was found that the optimum spacing (for two different manufacturers' microwave radio equipments) was  $\pm 8$  MHz from band center regardless of the 1F filter used. The optimum was reasonably broad (Fig. 15). At spacings that were too close, the crosstalk was primarily due to spectral components of one signal falling in the passband of the other's filter. Increasing the spacing much beyond the optimum value results in increased crosstalk due to AM to PM conversion in the TWTA. Also, in Fig. 15, it should be noted that the units of interference, when the carriers are too close, are in degrees. These units are values obtained from using the vectorscope as the measurement means (for reasons of accuracy and repeatability). The just-perceptible value of crosstalk interference in these units was three degrees (a  $p-p$  value of phase variation).

The source of the amplitude variation results from the effects of the filter skirts operating on the FM spectrum (Fig. 16). Nonlinear phase as well as nonflat amplitude response contribute to the FM to AM conversion. The component of the spectrum most prevalent at the band edge, where the problem is most severe, is the 3.58-MHz color subcarrier and, therefore, is the major contribution to the amplitude

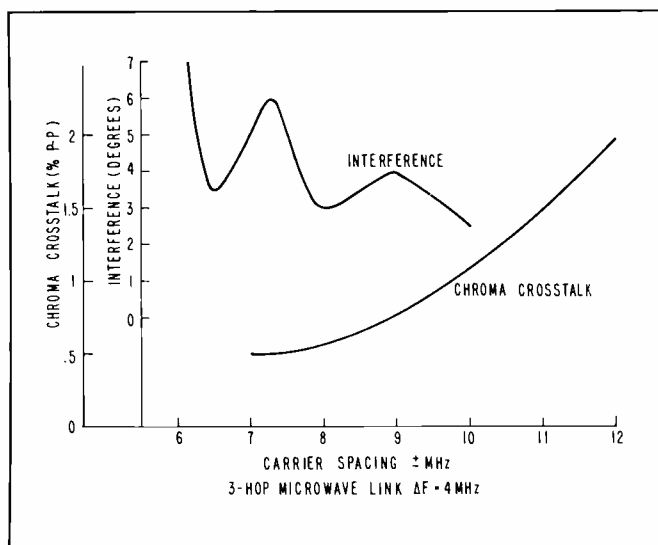


Fig. 15. Crosstalk versus carrier spacing.

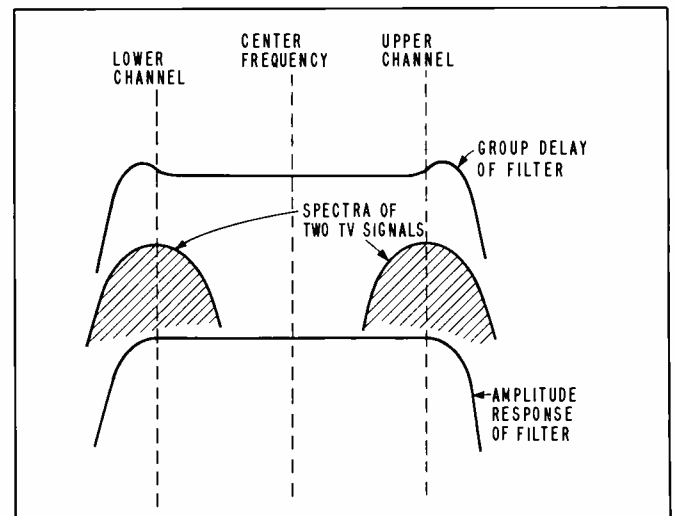


Fig. 16. FM to AM conversion mechanism for carriers with excessive spacing.



variation. Thus, the cross modulation produced in the other channel is observed most particularly in the chrominance (3.58-MHz) portion of the picture. This chrominance crosstalk is easily observed when the interfering signal contains high chrominance and the other channel has color bars as its input modulation. With the subcarriers not locked to one another, the effect is seen as an amplitude modulation on the color bars having a modulation rate equal to the difference in the two subcarrier frequencies. A waveform monitor is used for this observation. When viewed on a picture monitor, the visual effect is described as "breathing."

The vectorscope presentation also gives an indication of the phase modulation of the vector due to the summation of the interfering 3.58-MHz signal. For a point of reference, just perceptible crosstalk occurs (for a skilled observer viewing a picture monitor) when the amplitude variation as seen on the waveform monitor is 1.5 percent *p-p* of maximum luminance signal (100 IRE units on the waveform monitor represents maximum luminance signal). This 1.5 percent figure is true for the worst case of subcarrier difference frequency, namely, in the few cycles per second region. If the subcarriers are locked or differ at a rate too fast for the eye to track, the subjective result indicates that the allowable crosstalk figure is increased considerably from 1.5 percent.<sup>1</sup> As seen in Fig. 15, the chroma crosstalk can be as low as 0.5 percent when the path is well equalized.

If the TWTA backoff requirements were eased, for example, because the output filters eliminated the out-of-band IM products, there could still be a limitation on output power due to AM-to-PM conversion, and/or a reduction in deviation ( $\Delta f$ ) to reduce the FM-to-AM conversion would be necessary.

The occupied bandwidth of the two-carrier system was measured under conditions of abnormally high, but allowable, input video programming. Both channels were driven with 75-percent color bars at a  $\Delta f$  of 4 MHz. This signal is rich in 3.58-MHz content and produces a spectrum that is typically twice as wide as program video. The FCC specification of 99 percent of the total radiated spectral power being confined to the assigned channel bandwidth (30 MHz) was just met when both carriers were modulated by the 75-percent color bars. This answers the question regarding increasing the filter bandwidths and deviation beyond 16 MHz and 4 MHz, respectively, to further increase *S/N*. There appears to be in-

sufficient bandwidth to handle larger deviations without violating FCC regulations when very large chrominance signals are applied.

## Additional comments

The 2:1 video system described has been optimized for microwave radio systems based on experiments made on two different manufacturers' equipments. This technique is attractive in that only minor modifications must be made to existing microwave links for its incorporation. Although there were differences, and in one case requiring a change from a limiter/clipper IF to a linear AGC IF, the results were quite similar. A  $\Delta f$  of 4 MHz, using 16-MHz IF filters at the receiver, and a carrier spacing of  $\pm 8$  MHz from band center were found optimum in each case.

Acceptable performance was achieved with a 4.5- to 11.0-dB output-power backoff relative to the original saturated single carrier depending on specific equipment. One radio had narrower output rf filters and, therefore, required less output backoff.

## Operational implementation

The 2:1 experiments at the RCA Laboratories used modified radios from two different manufacturers. The first system used radios of the same type as at that time installed on RCA Americom's New York microwave. The second was a newly-purchased three-hop system from another manufacturer. The latter radios used linear AGC-type IF amplifiers and, therefore, required less modification than the first system. With these systems successfully demonstrated at the Laboratories, RCA Americom proceeded with plans for the operational implementation of one of the prototype 2:1 radios on the New York system.

The first step in this process was to present the results of the Laboratories' experiments, and RCA Americom's future plans for the use of 2:1 radios on the New York System to the FCC. In meetings held with the Commission, it was determined that the newly-purchased 2:1 system with linear AGC amplifiers had so little modification that it could be operated as a 2:1 radio with its existing type-acceptance as a 1:1 radio. This clinched the decision to use these radios in the operational system.

Expecting some problems over interference criteria in the coordination cy-

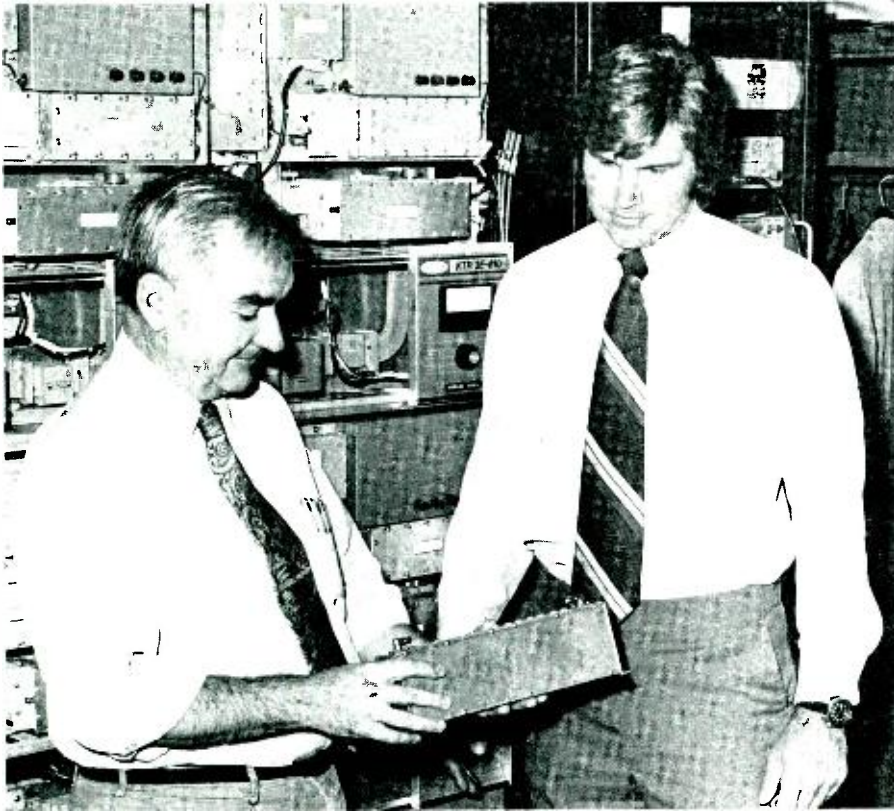
cle, and desiring to get the new radios installed as quickly as possible, RCA Americom worked out an agreement with the FCC to install and operate the 2:1 system under an experimental license. This allowed the installation and operation of the new system without completion of the coordination process.

After reaching an agreement over experimental licensing with the FCC, RCA Americom and RCA Laboratories proceeded immediately with the steps for operational installation. The three-hop system at the Laboratories was fully modified for field installation then tested and demonstrated at RCA Laboratories.

After final evaluation of system parameters, the entire system was moved to its current operational location in the New York microwave system. When installation on this system was completed, RCA Americom demonstrated equivalent results under normal operational conditions.

During the installation of the first "prototype" 2:1 system under experimental license, RCA Americom had filed a prior coordination notice for the system. In order to obtain a permanent license for the 2:1 radios to operate on the New York microwave, this coordination procedure must be successfully completed. RCA Americom initiated the coordination of the 2:1 radio assuming that the interference it caused would be no more objectionable than a standard video radio. In fact, there was reason to believe that its effect would be less objectionable due to the carrier offset and reduced power of each of the two carriers in the 2:1 radio.

One of the other common carriers did not agree with the analysis and proceeded, with the aid of RCA Americom, to establish interference objectives for this system. Their initial response established objectives which were as much as 30 dB more restrictive than those used for standard video services. Such objectives would preclude the use of the newly-developed system. RCA Americom, with the support of the RCA Laboratories, studied the approach taken by the other carrier and found that one of the reasons that such restrictive objectives were established was that they assumed that an unmodulated carrier could exist on the 2:1 system. RCA Americom assured them that an unmodulated carrier would not be allowed on the 2:1 system and requested that they re-establish their objectives using modulated carriers. RCA Americom's earlier studies indicated that much less restrictive interference objectives would be sufficient in



**Richard Klensch**, joined RCA Laboratories in 1952 and performed research in high-resolution radar systems and infrared detection devices. From 1954 to 1956, he served in the U.S. Army as a radar instructor, returning to the RCA Laboratories in 1956. Subsequently, he did research in microwave scanning antennas, time-division-multiplex systems, digital and analog communications and color television. Since 1975 he has been doing research in satellite and terrestrial audio and video communications techniques. In 1975 he received an RCA Laboratories Achievement Award.

Contact him at:  
**RCA Laboratories**  
**Princeton, N.J.**  
**TACNET: 226-2909**

**Steve Yablonski**, Manager of Advanced Technology Engineering at RCA Americom, joined RCA in 1975 as a Senior Member in the International Satellite Engineering group at RCA Globcom. He later moved to the System Engineering groups at RCA Americom when the new Domestic Common Carrier Company was formed from the domestic business of RCA Globcom.

Steve has worked in all phases of systems engineering for RCA Globcom and RCA Americom. Activities include video by satellite, audio by satellite, small dish distribution, RFI analysis and data systems.

Contact him at:  
**RCA Americom**  
**Princeton, N.J.**  
**TACNET: 258-4176**

this case. After a number of meetings and much give-and-take, they agreed to establish criteria based on modulated carriers. Their new criteria, although still more restrictive than the original criteria for standard video transmission, were sufficiently relaxed to allow 2:1 operation of three of the less critical channels in the New York system.

While these problems were being resolved, a requirement for two additional video channels was established for the New York microwave. This could only be met by the installation of two or more 2:1 radios.

The second and third 2:1 radios will be the first 2:1 radios purchased and installed as normal operational units outside RCA Americom's Advanced Technology development cycle. There were two options: first, the data generated by RCA Laboratories during the development of the 2:1 concept could be turned into a specification for a turnkey 2:1 radio system; and second, the manufacturers' standard radio packages could be purchased with custom branching networks and then modified in the field for 2:1 operation. After some discussion with the manufacturer, the second option was

chosen for the following reasons. Firstly, the vendor was not equipped to test a turnkey 2:1 system resulting in significant cost and schedule impacts. Secondly, the hardware used in the 2:1 system is identical to a standard system except for filters and waveguide branching at the terminal ends. By ordering standard radios with custom-branching network, the manufacturer can build and test them in his normal production facilities.

## System consideration and audio

This last section discusses the integration of the 2:1 radios into the existing New York microwave system including the provisions made for the audio channel associated with each video channel, and system protection.

The New York microwave system has six channels allocated to video service. These were originally configured in a 1:*N* protected system with one microwave radio channel left idle to protect five active channels.

The 2:1 radio uses 1:1 hot standby protection. In this system, the backup radio replaces the failed equipment on the same microwave channel.

As each 2:1 system is installed, it replaces one of the *N* active channels in the 1:*N* system. Operating outside the 1:*N* protection system, it reduces *N* by one and provides two video services on one microwave channel. If all channels were to be changed to 2:1's, the protection channel from the original 1:*N* system could be used for active service. This results in a total of 12 active video services between the New York central terminal office (CTO) and the Vernon Valley earth station, each with its own backup. The system then has more than double its original capacity of five active video services, and uses no additional microwave channels (that is, no new frequency allocations).

Until now, we have not addressed the question of how to transmit the associated audio channel. There are three options:

1. Transmit the audio as a subcarrier on each 2:1 channel;
2. Transmit the audio using group band modems in the message radio system; and
3. Transmit the audio using additional subcarriers on the remaining standard video radios in the New York microwave.

The second option has been eliminated

because of its relatively inefficient use of the available bandwidth on the New York system, and because of demands on the message microwave system.

The first option is still under consideration, however, due to problems confronted in purchasing the required subcarrier modules for the 2:1 radios, this concept has not been tested. RCA Laboratories testing has indicated that two audio subcarriers in the 5.5- to 7.0-MHz region can be operated on a 2:1 radio, but the magnitude of these carriers and their effect on the allowable deviation for the radios has not been determined. A test program will be undertaken as soon as the necessary equipment becomes available to resolve this question.

Present plans call for the use of the third option to provide audio for the 2:1 radios. Because of the large margins in a standard video radio system, two or three audio subcarriers can be accommodated on each video channel. By installing second and third subcarriers on the remaining standard video microwave radios, the six audios for the 2:1 radios can be accommodated. This technique makes efficient use of the available microwave channels, however, it cannot accommodate additional 2:1 radio installation on the New York system.

## Conclusion

Frequency congestion in the common-carrier frequency bands is causing communications bottlenecks in major cities. The 2:1 radio doubles the video channel capacity per unit bandwidth of a video microwave system. It has been installed, tested and is now operating on RCA Americom's New York microwave system. It uses standard video radios and the cost per channel on the New York system is less than that for the two conventional radios it replaces.

Although the 2:1 radio described was developed specifically for the New York microwave, its sufficiently general approach allows its application to any of RCA Americom's commercial microwave systems.

## Acknowledgments

The authors express their thanks to G.W. Beakley, W.D. Houghton, D.A. Walters and P. Schnitzler, who, at various times, helpfully managed the RCA Laboratories effort on this project.

The bulk of the measurements were made by K. Kelly with assistance of D. Zarodnansky.

RCA Americom's efforts were supported by G. Kaplan, who was involved with the system from its inception, and who was responsible for the first commercial installation on RCA Americom's system. Special acknowledgment must be made to J.D. Bowker, Director of the RCA Frequency Bureau, for his suggestions and assistance. R. Dombroski of RCA Americom was also helpful on matters dealing with the FCC.

Many invaluable technical discussions were had with H. Staras on matters of propagation and with L. Abbott regarding video distortion parameters. D. Fremont assisted in procuring equipment for experimentation. Information on microwave radio operation and television characteristics were given generously by G. Abernathy and A. Schroder, respectively.

## References

1. Abbott, L., Beakley, G. and Rowse, W.T., "Parameter Tradeoffs for Transmitting Two Television Channels per Transponder," *RCA Review*, Vol. 41 (Sept. 1980).
2. NTC Report No. 7, *Video Facility Testing -- Technical Performance Objectives*, Network Transmission Committee of the Video Transmission Engineering Advisory Committee, published by The Public Broadcasting Service (June 1975, revised 1976).

# Fiber optical communications: concepts, components and systems

*Just as communications engineers had to become familiar with computers and microprocessors during the 1970s, the knowledgeable engineer of the 1980s will design and feel comfortable with fiber-optic and quantum-electronic devices. Here's a descriptive overview of the technology.*

---

**Abstract:** *The authors present a comprehensive view of fiber-optic technology, including: advantages; fibers, sources and detectors; system descriptions; and commercial availability and future directions.*

---

Optical communications is often promoted as a "new" technology and a "coming revolution" in electronics. But, initial developments in this area must be traced to Alexander Graham Bell and his photophone — first conceived in 1878 just two years after his invention of the telephone. The photophone consisted of a sound-modulated mirror that reflected sunlight onto a selenium detector (also recently discovered in 1873) whose output current drove a telephone receiver. On April Fools' Day of 1880 Bell transmitted a message, via sunlight, over 213 meters and thereby transmitted one of the first wireless messages. Bell viewed the photophone as his greatest invention — even more so than the telephone. An interesting article on the photophone has been written by Mimms.<sup>1</sup>

Although Bell was very enthusiastic about his new development, he never came to grips with the problems of adequate transmission media (waveguides) or ever-present sources of light. Optical communications thus lay largely dormant until 1966 when Kao and Hockham<sup>2</sup> proposed the use of glass fibers as transmission media for light. They noted that although

the highest quality glass at that time had absorption coefficients on the order of 200 dB/km, a reduction in impurity content to nearly 1 ppm would result in absorption coefficients below 20-dB/km and could make light transmission over long distances a practical reality.

Two developments in 1970 then spurred the development of optical communications: the fabrication of glass fibers with absorption coefficients (losses) below 20-dB/km, and the demonstration of continuous wave (CW) lasing action (near 0.85  $\mu\text{m}$ ) at room temperature with aluminum-gallium-arsenide/gallium-arsenide (AlGaAs/GaAs) double-heterostructure injection lasers. Further advancements followed rapidly as listed here. In 1976, fibers with losses below 1-dB/km at a wavelength of 1.3  $\mu\text{m}$ , together with 1.3- $\mu\text{m}$  indium-gallium-arsenide-phosphide/indium phosphide (InGaAsP/InP) CW lasers, were reported. In 1979 fibers with losses near 0.2-dB/km at 1.55  $\mu\text{m}$ , together with appropriate InGaAsP/InP CW lasers were developed. This loss figure represents essentially the ultimate in performance since the lowest calculated loss is only 0.18-dB/km at 1.55  $\mu\text{m}$ . Repeaterless transmission lengths of over 100 kilometers and data rates of several gigabits can ultimately be realized with fiber optical systems at this wavelength. Although the minimum-loss wavelength can be shifted by hundreds of angstroms, no further reductions are expected at significantly longer wavelengths since the silicon dioxide ( $\text{SiO}_2$ ) molecule

has a fundamental absorption peak near 2.0  $\mu\text{m}$ . It should be mentioned here that suitable detectors (for example, Si for  $\lambda < 1.1 \mu\text{m}$  and Ge for  $1.1 < \lambda < 1.8 \mu\text{m}$ ) have been available commercially for some time.

## Advantages of Fiber Optics (F/O)

Table I contains a list of the major advantages of F/O. Optical communications depends on the propagation of light via glass fibers. The fiber acts as a dielectric waveguide for the electromagnetic (EM) wave associated with the light and thus conducts a field — *not* charge. The fiber is virtually immune to EM interference. Also, no spark insulation or common-ground problems exist in a F/O system. Since light waves represent a

**Table I. Advantages of fiber optics.**

1. Large Bandwidth: Light  $\sim 10^{14}$  Hz; Modulate  $>1$  GHz
2. Low Loss:  $<1$  dB/km;  $>100$ -km Repeater Spacing
3. Immune to EM Interference: Dielectric Fibers Guided Waves
4. Complete Electrical Isolation: No Common Ground
5. Lightweight: 2-10x Savings
6. Rugged and Durable:  $\sim 800^\circ\text{C}$ ,  $\sim 1\text{MPSI}$
7. Cheaper: No Raw Material Problems
8. Secure: Difficult to Tap
9. No Electrical Hazards

---

Reprint RE-26-3-6  
Final manuscript received Sept. 4, 1980.

carrier frequency of over  $10^{14}$  Hz, bandwidths of hundreds of gigahertz are theoretically possible — only fiber dispersion and the frequency response of sources and detectors limit the ultimate modulation capacities. Modulation rates of several GHz have already been demonstrated.

The low attenuation losses of silica fibers have already been mentioned. Fiber losses below 0.5-dB/km allow fiber lengths of over 100 km to be used without amplification (repeaters). In fact, a F/O link of over 116 km consisting of seven 16.6-km spliced fibers was recently demonstrated<sup>3</sup> at data rates of 37-Mbits/s (with a 1.3- $\mu$ m source) and at 17-Mbits/s (with a 1.55- $\mu$ m source). Although these values represent state-of-the-art laboratory results, they will almost surely be realized soon in commercial systems.

Optical fibers are difficult to “tap” — especially for analog data — and therefore offer a method for communications that is more secure than conventional coaxial or microwave systems. Fibers are also lightweight — anywhere from two-to-ten times lighter than coaxial cable. For example, weight savings of 70-370 pounds can be realized on military aircraft by using optical fibers instead of wire systems.<sup>4</sup>

Finally, silica fibers are rugged and durable. Trade shows often feature a closed-circuit television image carried over a F/O cable laid out on the floor for all to walk and stomp upon. And silica fibers have no foreign supply problems. The cost-effectiveness of F/O systems has already been demonstrated in many applications and will continue to improve. For example, a comparison<sup>1</sup> of a coaxial versus a F/O 5000-km underwater cable system has shown that the F/O system could have twice as many channels (600 versus 300) at less than one-third the cost (\$50K/channel versus \$14K/channel). Perhaps the most important advantage of F/O, however, is that it enables information to be transmitted over distances and at rates that are difficult or impossible to achieve with coaxial or microwave systems.

## Fibers, sources and detectors

Since the cost of the optical fiber dominates the system cost, all other components must be designed around the fiber. In this section, the properties of optical fibers will be discussed first. Then, sources and detectors, appropriate for particular types of fibers, will be described. References 5 and 6 give good, detailed

treatments of the principles and properties of fibers. References 6-8 contain detailed descriptions of device properties.

## Fibers

The basic principles of light propagation in optical fibers can be discussed with the aid of Fig. 1. Direct application of Maxwell's equations predicts that only light with an incidence angle less than  $\theta_m$ , given by

$$\sin \theta_m = (n_{core}^2 - n_{cladding}^2)^{1/2} = NA^*$$

\*NA = numerical aperture

will be accepted and propagated by the fiber. Two main types of fibers are used: step-index and graded-index. Figure 2 depicts the difference between these fibers. The step-index fiber is the lowest-cost silica fiber and has the highest acceptance angle (for a given fiber diameter). Although dispersion losses are relatively high, this fiber is useful for low-cost light-emitting-diode (LED) systems. By grading the refractive-index profile (at somewhat higher cost) the optical path length for different modes can be made more equal, thus lowering dispersion loss. Most laser-driven systems use this type of fiber. If the core of a step-index fiber is made sufficiently small ( $\sim 2$ -10  $\mu$ m) only one mode will be supported, thus giving rise to a single-mode fiber. This type of fiber gives the ultimate in long-length high-data-rate performance.

Fibers are made of plastics (high loss, low cost) as well as silica (low loss, high cost) doped with various materials. By tailoring the refractive index and the purity of SiO<sub>2</sub>, we can minimize attenuation loss and dispersion at particular wavelengths. Fibers are typically specified by their loss (dB/km), dispersion (ns/km), modal properties (single or multi) and numerical aperture (light-gathering ability).

Figure 3 shows a plot of a silica-fiber's attenuation loss versus wavelength (the fiber was optimized for 1.55- $\mu$ m operation). In general, fiber loss decreases with wavelength (as does Rayleigh scattering) up to wavelengths near 1.6  $\mu$ m. Because of a fundamental absorption peak of the SiO<sub>2</sub> molecule near 2  $\mu$ m, losses increase beyond 1.6  $\mu$ m. The loss at other wavelengths (for example, 0.85  $\mu$ m and 1.3  $\mu$ m) can be made somewhat lower than that depicted in Fig. 3 via appropriate fabrication techniques. But the 0.2-dB/km value at 1.55  $\mu$ m seems to be the minimum that will be obtained with silica fibers.

The advantages of F/O systems that operate at wavelengths greater than 1  $\mu$ m go beyond lower fiber loss. Larger

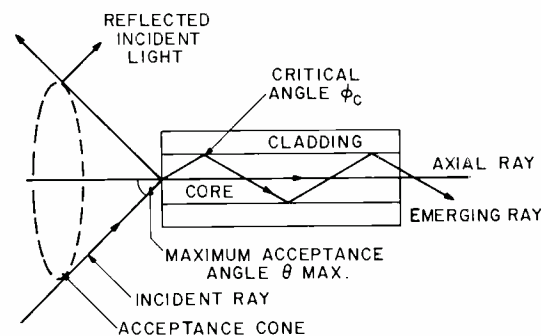


Fig. 1. Ray diagram that shows the maximum angle of incidence for light to be accepted by and propagated in an optical fiber.

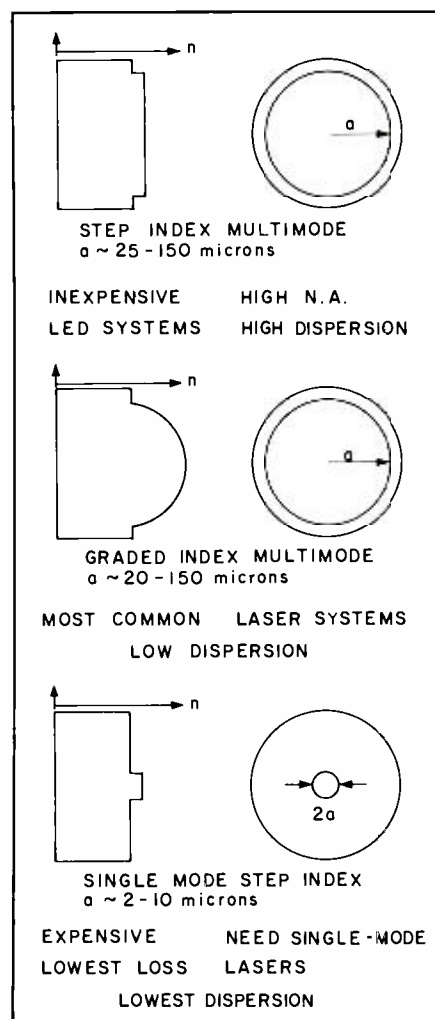


Fig. 2. Three main types of optical fibers.

bandwidths are possible because of smaller material dispersion in the fiber. Eye safety can also be greatly improved: maximum allowable exposure to pulsed light with  $\lambda > 1.4 \mu$ m can be up to 10,000 X that for  $\lambda < 1.4 \mu$ m. Finally, light waves near 1.5  $\mu$ m transmit considerably better through smoke and haze, thus benefiting military and satellite applications. Table II shows

some typical fiber properties at various wavelengths.

Systems were initially operated at 0.85  $\mu\text{m}$  because the only available sources were at this wavelength. Figure 4 demonstrates how the low losses in fibers designed for long wavelength can lead to much longer *repeaterless* links. The plot assumes several mW of power launched into the fiber and the ellipses denote the sensitivity of available detectors (Si APD for 0.85  $\mu\text{m}$  — PIN detectors for 1.3 and 1.55  $\mu\text{m}$ ). Even with less-sensitive detectors, the lower fiber loss of the long-wavelength system clearly leads to much longer links.

### Sources

Laser diodes and LEDs are constructed from semiconductor materials that have direct-energy bandgaps. These materials allow carrier transitions from the conduction to valence band to be made without momentum changes (that is, phonon transport) and therefore have high radiative recombination efficiencies. The successful tailoring of these devices requires the following:

- A material with the desired emission wavelength (determined by the direct-energy bandgap) to serve as the lasing medium;
- A higher bandgap ( $\Delta E_g \geq 0.2 \text{ eV}$ ) material for carrier confinement, with atomic lattice spacing equal to that of the lasing medium, that can be synthesized together with the medium. (The high bandgap material must also have lower refractive index ( $\Delta n \geq 0.2$ ) to properly confine the light);
- A readily available substrate whose lattice spacing is the same to support the devices.

Alloys of III-V compounds will meet all

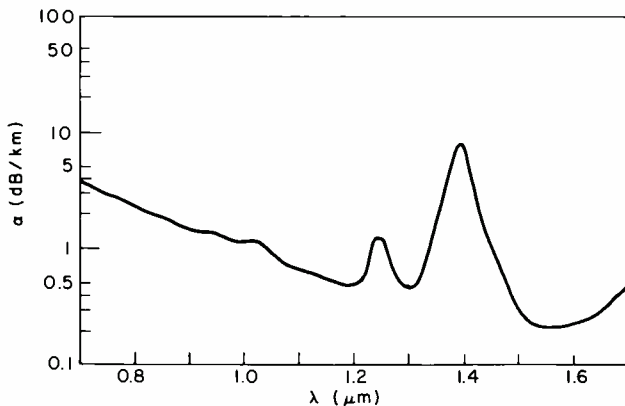


Fig. 3. Attenuation loss versus wavelength for high-quality silica fibers.

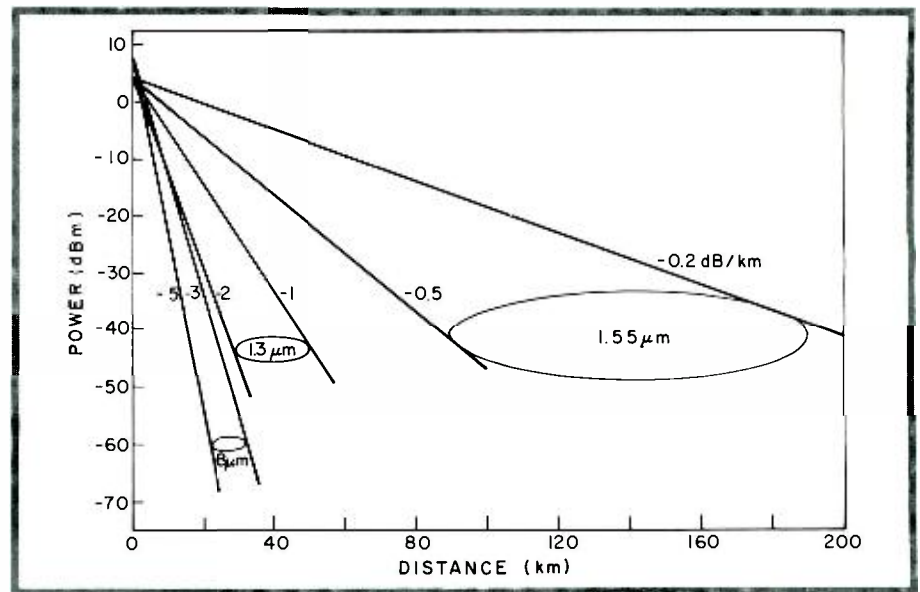


Fig. 4. Total loss (in dBm: referenced to 1mW) versus distance in fiber optical systems operating at 0.85  $\mu\text{m}$ , 1.3  $\mu\text{m}$  and 1.55  $\mu\text{m}$ .

of these requirements. In fact they are the only known compounds from which practical semiconductor injection-laser diodes for the 0.6 to 2.0  $\mu\text{m}$  spectral region have been made. Figure 5 shows a plot of energy bandgap and lattice parameter for the III-V semiconducting compounds. This plot greatly aids the selection of materials.<sup>6,7</sup> The binary alloys are indicated by points. These alloys have fixed lattice parameters and bandgaps. Ternary alloys are denoted by lines between the binaries. These alloys have one degree of freedom — a range of bandgaps may be chosen although each bandgap has a single fixed-lattice parameter. Quaternary alloys are denoted by areas defined by four binary alloys. These alloys have two degrees of freedom since a range of lattice parameters is available for each bandgap. Conversely, a range of bandgaps is available for each lattice parameter — really the attractive

feature of the quaternary-alloy system. Quinary (five-component) alloys allow three degrees of freedom so that, for instance, refractive index could be varied while lattice parameter and bandgap are held constant.<sup>7</sup>

Figure 6 shows an idealized sketch of a typical double-heterojunction semiconductor-laser energy-band diagram and refractive index profile. The laser cavity consists of undoped low-bandgap material surrounded by higher-bandgap *N*- and *P*-type material. Under forward bias, electrons from the *N*-type material and holes from the *P*-type material are injected into the laser cavity. These carriers are confined to the laser cavity by the energy barrier at each heterojunction. This confinement, together with the high radiative recombination rates of direct-bandgap materials, promotes an efficient electron-hole recombination in the laser cavity that generates spontaneous emission. At this stage the device functions as a LED, and the radiation propagates initially in a Lambertian fashion (uniformly in all direction). Although the internal quantum efficiency — the ratio of radiative recombination rate of carriers to total recombination rate in the cavity — can be

Table II. Typical fiber properties.

	0.85 $\mu\text{m}$	1.30 $\mu\text{m}$	1.55 $\mu\text{m}$
absorption (dB/km)	2-5	0.5-1.0	0.2-0.5
single-mode (ps/km)			
fiber dispersion	100	1-5	1-5
ultimate data rate • length (Gbit • km/s)	5-10	50-100	100-200

greater than 50 percent, the external quantum efficiency — ratio of photons emitted from device to input electrical power — is, at best, only a few percent. External quantum efficiency is low because the small critical angle for total internal reflection ( $\sim 17^\circ$ ), caused by the high semiconductor refractive index ( $\sim 3.5$ ), allows most of the radiation to be trapped and absorbed in the device.

Any photon generated within the cavity can stimulate the recombination of additional electron-hole pairs to emit photons that are coherent with it (have the same wavelength and phase). As injection increases, the gain due to stimulated emission can approach and exceed the absorption losses of the cavity. When this happens (at injection levels  $\sim 10^{18}$  carriers/cm<sup>3</sup>), the device becomes an amplifier and the intensities of all modes of the optical field increase. The waveguiding effect of the confining layers (caused by the refractive index step) and the gain profile of the device (defined by material parameters) allow certain select modes of the optical field that are nearly perpendicular to the facets to achieve much greater net amplification (incur much lower loss) than others. A narrowing of the emitted spectrum together with an abrupt increase in emitted power occurs. The device is now said to *lase*.

Whereas spontaneous emission has a spectral half-width of several hundred angstroms, coherent emission has a spectral half-width of only tens of angstroms. In turn, individual modes with half-widths of tenth of an angstrom or less form this spectral half-width. Since the stimulated lifetime is much shorter than the spon-

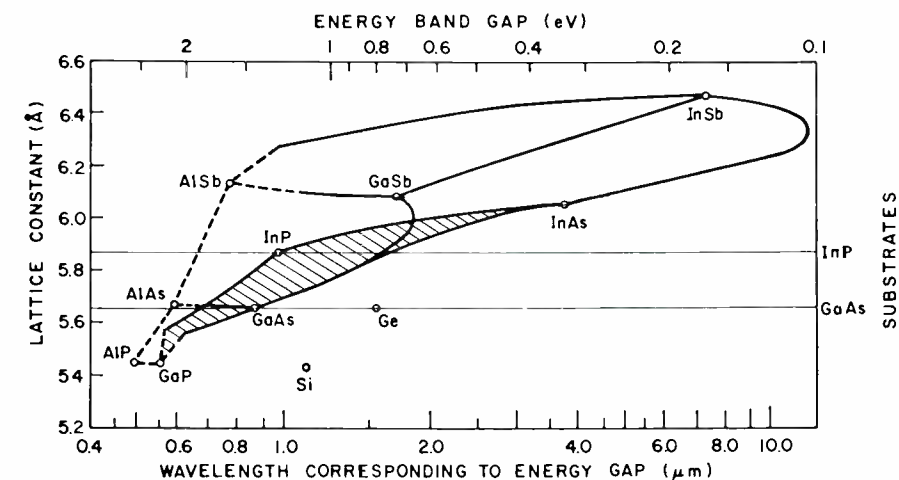


Fig. 5. Energy bandgap and lattice parameter for binary, ternary and quaternary III - V compounds.

taneous lifetime of minority carriers (typically  $\sim 10^{-11}$  s versus  $10^{-9}$  s), further increases in input current will result almost entirely in stimulated emission and the differential quantum efficiency (rate of change of photons emitted to total injected carriers) of the lasing process can be as high as 50 to 100 percent. The current density at which the device begins to lase is called the threshold current density. This relatively high differential quantum efficiency, together with small size and low-power requirements, is what distinguishes semiconductor injection lasers from all other types. The external efficiency of this process is usually below 15 percent.

Figure 7 contains a plot of output optical power versus input current — the usual transfer characteristic curve — for a CW laser diode. The threshold current ( $I_{th}$ ) marks the boundary below which spon-

taneous (LED) emission predominates and above which coherent (lasing) emission predominates. Spontaneous emission depends on minority carrier lifetimes that are typically several nanoseconds and that limit modulation rates to only a few hundred megahertz. Stimulated emission is limited by photon lifetimes in the cavity. These lifetimes are typically in the picosecond range and thus easily allow gigahertz modulation rates. The frequency response ( $R$ ) for a LED is commonly expressed as

$$R = (1 + (2\pi ft)^2)^{-1/2}$$

where  $f$  is the modulation frequency and  $t$  is the switching time or injected carrier lifetime. Figure 8 compares LEDs' and lasers' frequency response. Note the much higher response of the laser ( $\sim 10X$ ).

Commercial LEDs emit  $\sim 0.5$ -5 mW up to their maximum, safe-operating current of about 200 mA. In contrast, typical

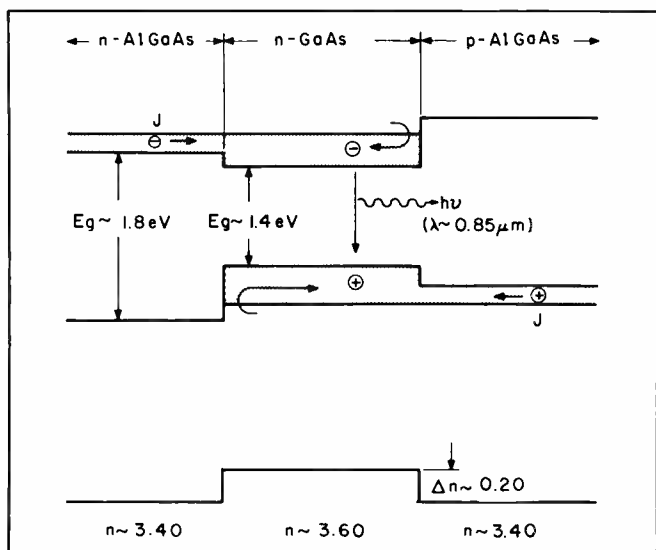


Fig. 6. Energy-bandgap step and refractive-index step for GaAs/-AlGaAs double-heterostructure laser.

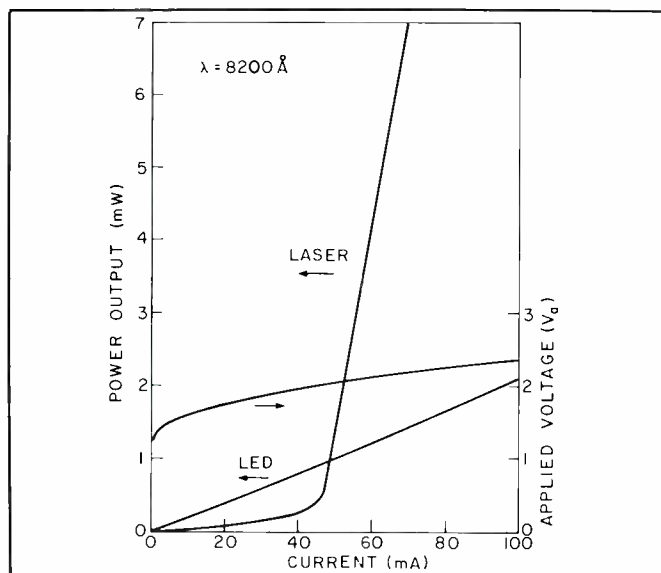


Fig. 7. Output power versus input current for lasers and LEDs.

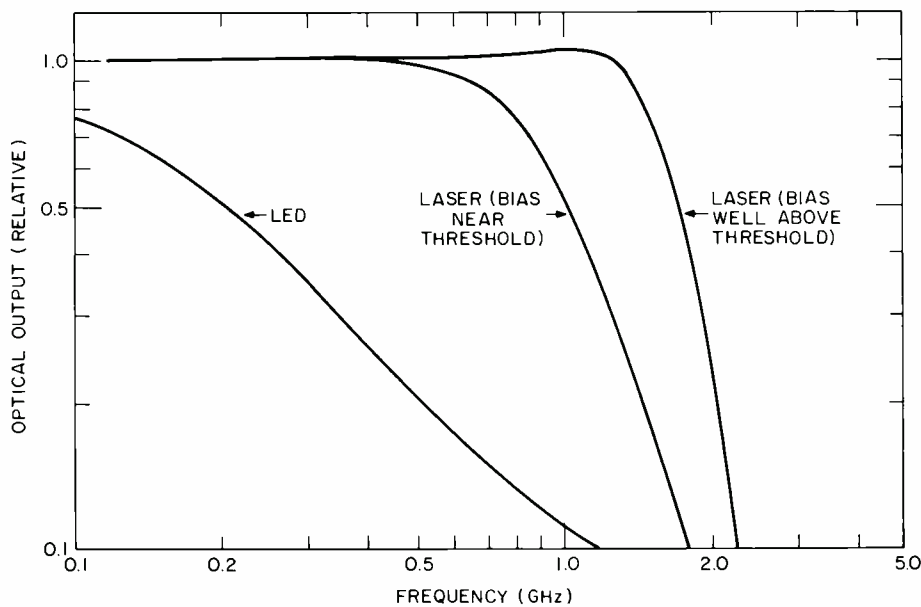


Fig. 8. Relative output versus frequency for LEDs and lasers.

commercial lasers have threshold currents of between 20 and 200 mA, with power outputs in the 1-10 mW range. But the difference in total power output between the LED and laser is not the only distinguishing characteristic. Characteristics such as beam pattern spectral width and modulation capability are also important. In Fig. 9, the LEDs' beam patterns are basically omnidirectional (lambertian). The edge-emitting LED, because of the waveguide nature of the double hetero-junction perpendicular to the junction, has a directed beam ( $\sim 30^\circ$  at full-width half-power). The laser has a directed fan-shaped beam ( $\sim 35^\circ \times 7^\circ$ ), because it is emitted from a small waveguide source  $\sim 2 \times 10 \mu\text{m}$  in cross-section. Because fibers only have a limited acceptance angle ( $\sim 20^\circ$  for a typical 0.2 NA fiber), the beam angle basically fixes the coupling efficiency if the source emission area is smaller than the fiber diameter. Lasers achieve coupling efficiencies of  $\sim 50$  percent for useful multimode fibers (NA  $\sim 0.2$ ) in contrast to the few percent efficiencies of LEDs. Therefore, coupled powers for LEDs are only  $\sim 0.1$  mW and those for lasers are  $\sim 1$  mW. The edge-emitting LEDs have greater coupling efficiencies but suffer from somewhat lower emission efficiencies.

In total, for typical communications fibers, edge- and surface-emitting LEDs couple comparable optical powers into the fiber. Because the coupling of light sources to fibers requires some mechanical precision and stability, and because the user often has difficulty estimating and maximizing the coupled efficiency, sources are usually sold with fiber "pigtailed" attached.

That is, the manufacturers sell the light source with  $\sim 1$  meter of the desired fiber permanently attached and coupled. The fiber may be terminated with a fiber-to-fiber coupler. In addition, the light source and the driving electronics for the light source may also be combined as shown in Fig. 10 (an RCA LED drive module). The manufacturer of the pigtail configuration specifies the coupled optical power at a given source's drive current—a more useful parameter than the total power output of the source alone.

In addition to the beam pattern and light-emission area, the spectrum of the source is very important. Sources of (AlGa)As are commercially available at  $820 \pm 40$  nm. Lasers and LEDs made of InGaAsP at  $\sim 1.3 \mu\text{m}$  are still in research and development. Lasers typically have  $\sim 20 \text{ \AA}$  spectral widths that consist of a few modes. Single-mode devices with spectral widths of less than  $0.1 \text{ \AA}$  are available but the mode may change (hop) with drive or temperature so that the effective spectral width during a pulse may be larger ( $\sim 5 \text{ \AA}$ ). LEDs at  $0.8 \mu\text{m}$  have spectral widths (full-width half-power) between 200 and  $500 \text{ \AA}$ , while those at  $1.3$  and  $1.5 \mu\text{m}$  are 600 to  $1200 \text{ \AA}$  wide. As noted in other sections of this paper (especially for LEDs), the spectral width limits the bandwidth-distance product of the system because material-related spectral dispersion occurs in the fiber, so that the narrowest spectral-width sources are desirable.

The beneficial properties of lasers are offset by some penalties. Lasers are nonlinear threshold devices, so the driving electronics are more complicated. Further-

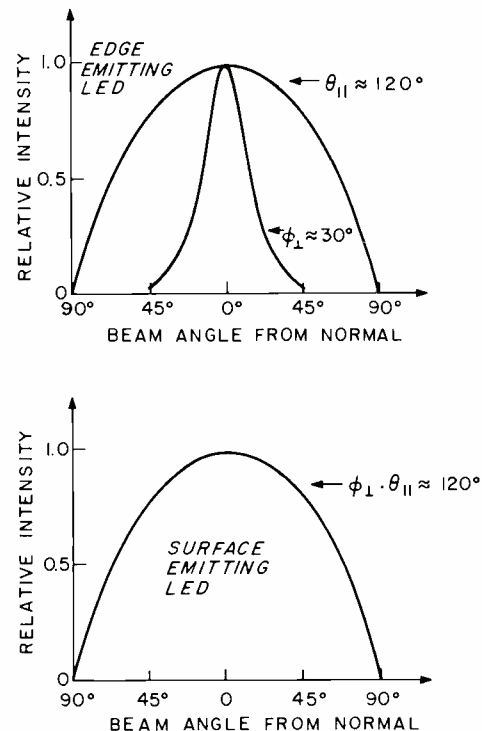


Fig. 9. Far-field beam patterns for edge-emitting and surface-emitting LEDs.

more, the lasing threshold is temperature sensitive—as illustrated in Fig. 11—thus requiring either thermoelectric-temperature-stabilization or optical-output-stabilization circuitry. On the other hand, though the LED efficiencies show some temperature sensitivity, the output variations for a given temperature change are small compared to those of lasers—over a normal ambient temperature these output variations are acceptable from a system viewpoint. Lasers of different materials and construction show differing sensitivities. Typically, (AlGa)As lasers increase about 25- to 50-percent between ambients of  $20$  and  $70^\circ\text{C}$ , but InGaAsP devices are more temperature sensitive and exhibit approximately 100 percent increase. The threshold ( $I_{th}$ ) temperature sensitivity is exponential such that

$$I_{th} \propto \exp \frac{\Delta T}{T_0}$$

For (AlGa)As lasers,  $T_0 \cong 150^\circ\text{C}$  and for (InGa)(AsP) lasers,  $T_0 \cong 60^\circ\text{C}$ . Lasers can also exhibit changes in beam pattern and show associated nonlinearities in the power output-current input characteristics. These problems have been greatly reduced in the most recent laser devices where, in a variety of different structures, the built-in waveguide is made stronger in the plane of the junction plane to obtain linear characteristics and single-lobed stable beam patterns.



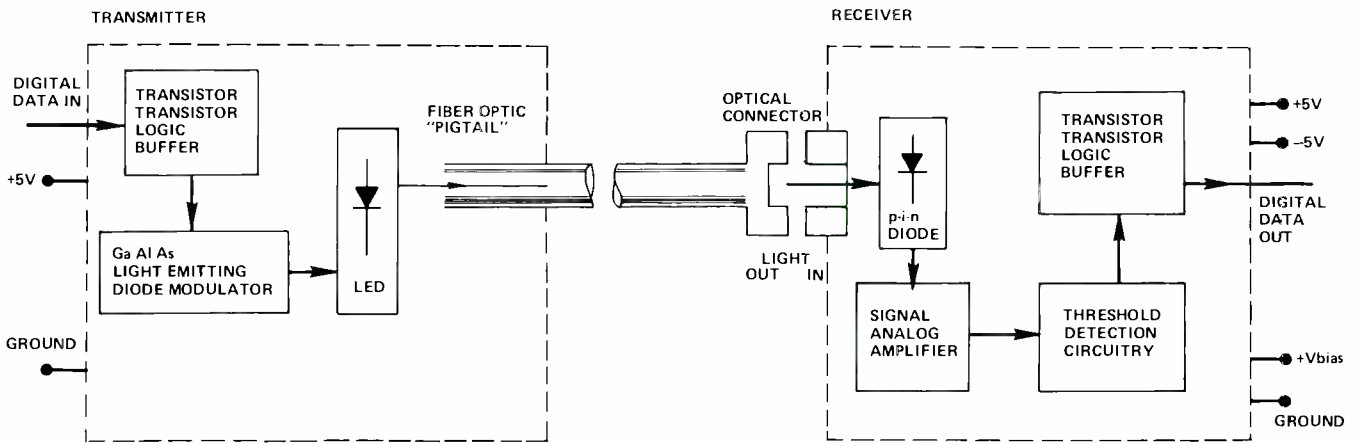


Fig. 10. Circuitry for device electronics used for RCA lasers and LEDs.

### Detectors

The detector's purpose in a F/O system is to convert incoming photons to electrical carriers. Si and Ge detectors of small size, high efficiency and large bandwidth were developed long before the advent of F/O and are well suited for the application. A fiber can be easily coupled to the detector since the detectors are usually somewhat larger than the fiber diameter and have large acceptance angles. In some cases, connectors with large-diameter large-NA fibers are supplied with the detector. Ideally, these devices will have high sensitivity, low-noise and fast-response time.

Structures used for photodetectors are the PIN detector (with no internal gain) and the avalanche photodetector (with internal gain). Figure 12 shows these structures for typical silicon devices (sensitive over the range  $0.4 < \lambda < 1.1 \mu\text{m}$ ). In a PIN device, incoming light gets absorbed throughout the device—which must be 150-250  $\mu\text{m}$  thick for complete absorption—and creates electron-hole pairs much the same way a solar cell does. A reverse bias applied to the device depletes the *I* region and creates a drift field that transports carriers to the *P* and *N* regions and thereby creates photocurrent. Quantum efficiencies in excess of 80 percent (at 0.8  $\mu\text{m}$ ) and nanosecond rise-times are possible. Dark currents (currents which flow in the absence of signal) in the nanoamp range and noise equivalent powers (NEP is the power that yields a *S/N* ratio of 1 at a specified bandwidth) on the order of  $10^{-13} \text{ W/Hz}^{1/2}$  are possible.

For the APD structure shown, the device is placed under reverse bias which is sufficiently high to initiate avalanche breakdown at the *P/N* junction. Any photocarriers swept into this high field region get accelerated. They smash into

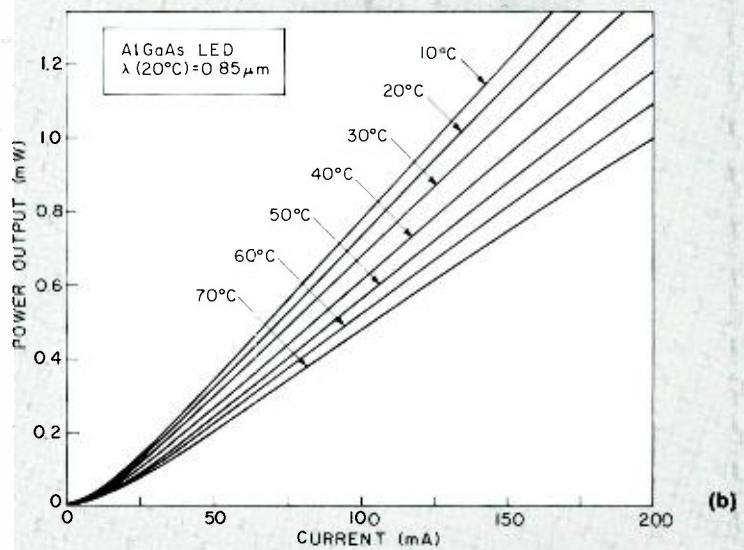
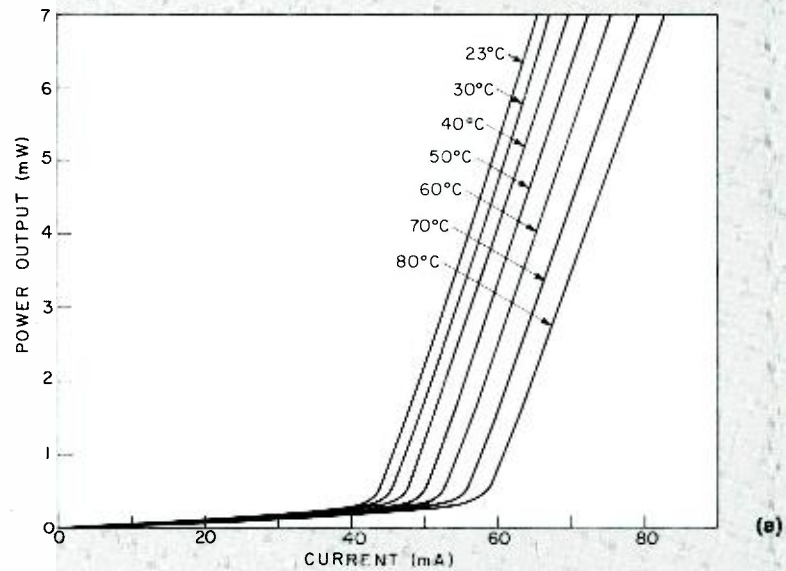


Fig. 11. Output power versus input current as a function of temperature for (a) lasers and (b) LEDs.

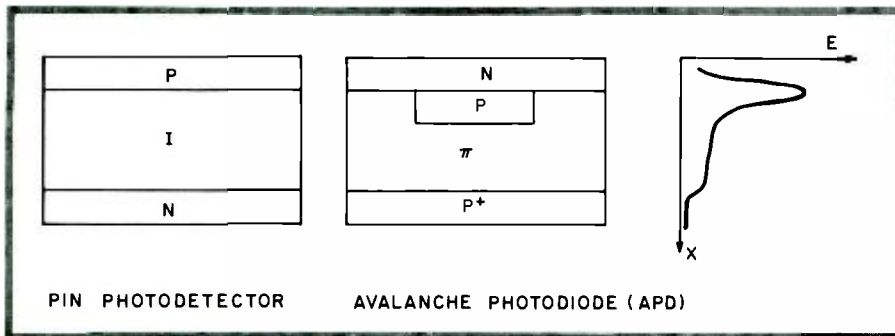


Fig. 12. Sketch of PIN detector and an avalanche photodiode.

stationary atoms where they free additional carriers via impact ionization. Gains in excess of 100 are possible.  $NEP$  values on the order of  $10^{-15} W/Hz^{1/2}$  (for a 10 KHz bandwidth) are possible.

For wavelengths in excess of  $1.1 \mu m$ , *Ge* or *III-V* compound detectors must be used. Although gains on the order of 40 are possible with *Ge APDs*, these devices exhibit relatively high noise ( $NEP > 10^{-12} W/Hz^{1/2}$ ) and leakage currents ( $> 10 \mu A$ ) due to their lower indirect energy bandgaps. No *III-V APD* devices are yet commercially available, but these devices have the potential for lower noise and higher speed because of their direct bandgap structure.

A promising *III-V* detector structure (under development at a number of laboratories<sup>9</sup>) is shown in Fig. 13. Here, the low-bandgap  $In_{.53}Ga_{.47}As$  layer absorbs light (up to  $1.7 \mu m$ ) and the current is collected across a *P/N* junction in the high-bandgap (low-leakage) *InP*. The direct bandgap structure allows the *InGaAs* layer to be only several microns thick for complete absorption of light. On the other hand, limited diffusion length forces it to be located within about  $1 \mu m$  from the *P/N* junction. This device could also be operated as an APD although some system performance/cost analyses indicate that favorable performance can sometimes be achieved with (*InGaAs*)-PIN detectors coupled with low-noise-FET amplifiers.

### Reliability

LEDs and lasers operate at current densities  $> 10 \mu A/cm^2$  and lasers have emission intensities at their mirrors of  $> 10^6 W/cm^2$ . For these reasons, the first CW lasers operated only a few minutes before they failed. We have come a long way since that time and good commercial CW lasers have mean times to failure that approach 100 years<sup>(10)</sup> ( $\sim 10^6$  hours).

LED and laser failures follow a log-

normal distribution (a gaussian distribution on logarithmic coordinants). Illustrated in Fig. 14 are the laser failures as a function of time on log-normal coordinants for a group of five-year-old devices operated continuously at room temperature. Figure 14, also shows the results for another more recent group, operated in an accelerated mode at  $70^\circ C$ . The data can be extrapolated back to room temperature by assuming an activation energy of 0.7 eV for failure.<sup>10</sup>

The median time to failure for these devices is  $\sim 4000$  hours at  $70^\circ C$  and  $\sim 100,000$  hours at  $22^\circ C$ . Even though LEDs and lasers are similarly constructed, LEDs are basically more reliable than lasers because they are operated at somewhat lower current densities, are less sensitive to mirror and contact conditions and do not have a temperature-sensitive threshold. LEDs have been reported with mean-time-to-failure (MTTF) of  $10^9$  hours at room temperature.<sup>11</sup>

Most recent data<sup>(11), (12)</sup> seems to suggest that the long-wavelength *InGaAsP* devices may be even more reliable than their (*AlGa*)*As* counterparts. In fact, we have had LEDs operating for more than 14,000 hours at  $70^\circ C$  without significant decreases in output. Reliability of the sources is adequate for most systems applications. There is, however, limited field trial reliability information (what little there is, is encouraging) for both *AlGaAs* and *InGaAsP* devices. More statistical evidence is required before these devices can be considered to have reliabilities comparable to silicon transistors.

### F/O systems

#### System description

An optical data link is the simplest configuration for an optical communication system, and has the essential elements of more complicated configurations. It gives point-to-point, unidirectional transmis-

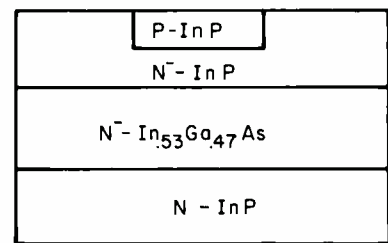


Fig. 13. Novel structure of a long ( $> 1 \mu m$ ) wavelength photodetector. Light absorption takes place in the low-bandgap *InGaAs* layer, whereas current is collected across the *P/N* junction in the high-bandgap *InP*.

sion of digital data. The basic elements are shown in Fig. 15. A stream of digital data at some standard logic level (TTL for data rates less than 20 MHz, ECL for high rates) enters the transmitter. Here, the data controls the current applied to the light source (laser or light-emitting diode) to produce a modulated light output corresponding to the data. This light is coupled into a glass optical fiber and guided, over distances ranging from meters to kilometers, to the receiver. At the receiver the light signal is converted into an electrical signal by a photodetector and transformed back to standard logic levels. A long data link may include one or more repeaters. Repeaters are combined receiver-transmitters that maintain the

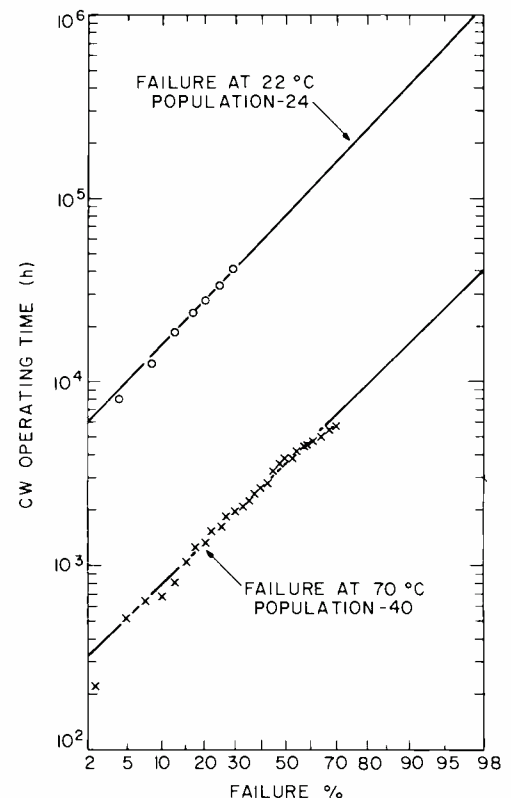


Fig. 14. Log-normal plot of mean time to failure for *AlGaAs* lasers at  $22^\circ$  and  $70^\circ C$ .

amplitude and fidelity of the optical data stream.

It seems from this brief description that an optical link begins and ends with electrical data at standard logic levels, and that it is therefore irrelevant to the user whether the transmission is by optical fiber, coaxial cable or twisted pairs of wires, so long as the data is transmitted the required distance with sufficient accuracy. This may be true, but the technical and economic characteristics of optical fiber transmission can lead to alternative trade-offs in system design. For example, the lower error rate and greater interference immunity of fiber systems can reduce the need for error-detecting and correcting codes in the data format. The high bandwidth of fibers favors serial data transmission at high bit rates, rather than parallel transmission at lower rates.

## Data link elements

The three key elements of a basic data link are the transmitter, fiber transmission line and receiver. Their performance will determine that of the link as a whole.

### Optical transmitter

Figure 16 shows the basic layout of an optical transmitter. The data stream is transformed by a buffer to a suitable level to operate the driver amplifier. Optical diodes operate as low-impedance ( $\sim 2-4$  ohms) forward-biased diodes. The driver is, therefore, a switched current source. In the case of a laser diode, a DC bias current is also applied to bring the device to its lasing threshold. The resulting modulated light consists of pulses corresponding to the data being transmitted superimposed on a background determined by the choice of bias point and the modulation depth.

Light from the emitting diode must be efficiently coupled into the optical fiber. In most cases a fiber "pigtail" is provided with the diode. This carries light from the diode

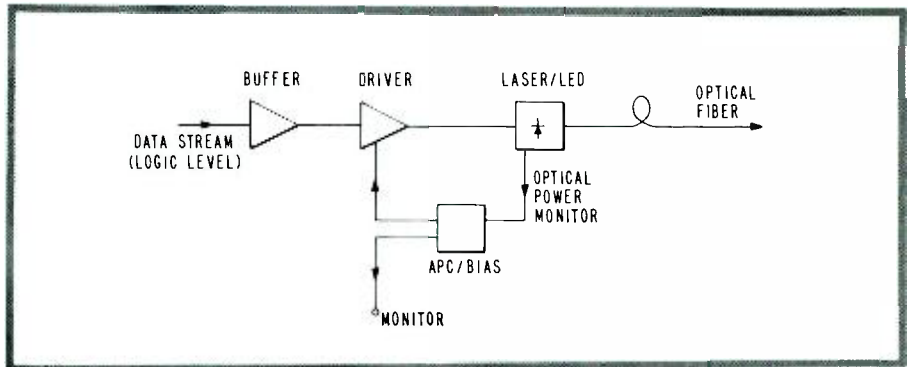


Fig. 16. Components of a fiber optic transmitting system.

to a terminal where the connection to the transmission fiber is made with a standard fiber coupler.

The power output of emitting diodes, especially lasers, diminishes with aging and with increasing temperature. A system with high reliability and minimum maintenance will incorporate means for automatic bias adjustment and power control (APC). This is usually accomplished by detecting a fraction of the output light and using the resultant signal as the input to a feedback loop to the driver. The same circuit can also provide a monitor port for in-service maintenance checks. In addition, laser systems often incorporate temperature sensors and thermoelectric coolers to maintain constant power output.

### Optical fiber transmission lines

The optical fiber has been treated in detail in the components section. From the point of view of system design, the two most significant variables are the attenuation and the bandwidth. Attenuation of the transmitted light reduces the received optical signal and thereby degrades the signal to noise ratio of the link. Bandwidth limitations cause broadening of the optical pulses, to the point where they overlap. With current fibers the attenuation and bandwidth characteristics are significantly better than the corresponding characteristics of coaxial cable. Figure 17

shows a comparison of optical fibers and coaxial cables.

Unlike coaxial cable systems, the fiber transmission characteristics are closely related to the particular kind of optical source chosen. In the section on system performance, the transmission characteristics of various source-fiber combinations will be compared.

### Optical receiver

The basic elements of an optical data receiver for digital signals are shown in Fig. 18. Here, the light signal from the optical fiber is converted into an electrical signal by the photodiode (PIN photodiode or avalanche photodiode). A preamplifier stage provides initial amplification and transforms the impedance level to facilitate further amplification. The gain amplifier brings the signal level up to the point where conversion to logic levels is possible.

Up to this point the receiver is providing broadband amplification of the received signal. The data detector receives the amplified signal, together with associated noise, and converts it to a clocked digital data stream. It compares the signal levels to a reference level and makes a decision with each clock pulse whether the signal level is above the reference level (a binary "1") or below the reference level (a binary "0"). The result is a reconstructed data stream that, after final buffering and logic level conversion, is transmitted to the user.

Proper functioning of the data detector requires two additional functions within the receiver. First, the receiver clock must be synchronized with the data. The exact clock frequency may be derived from the harmonic content of the data itself. The data format must allow for synchronization recovery without loss of essential data. Second, the threshold must be set according to the peak level of the signal. This level detector can also provide an AGC

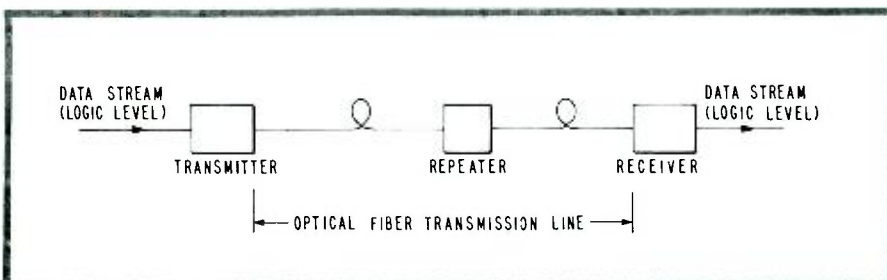


Fig. 15. Sketch of a basic fiber optic data link.

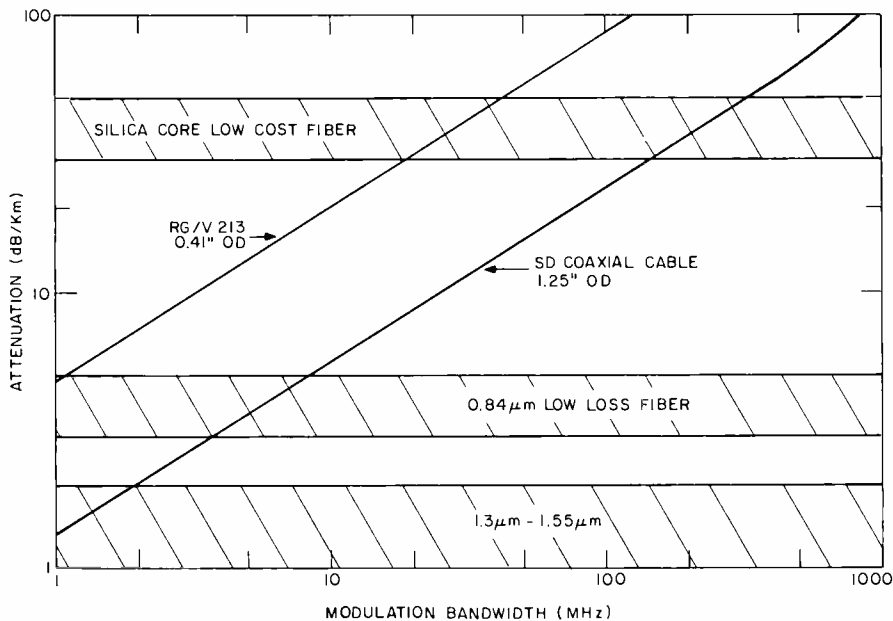


Fig. 17. Attenuation loss versus modulation bandwidth for coaxial cable and optical fibers.

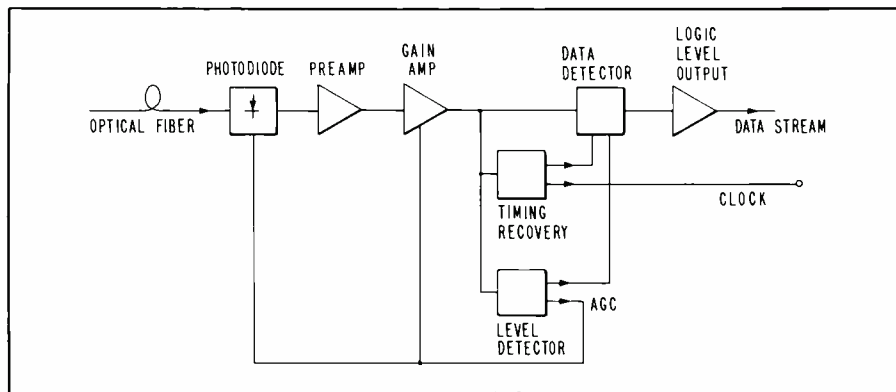


Fig. 18. Basic layout for an optical data receiver.

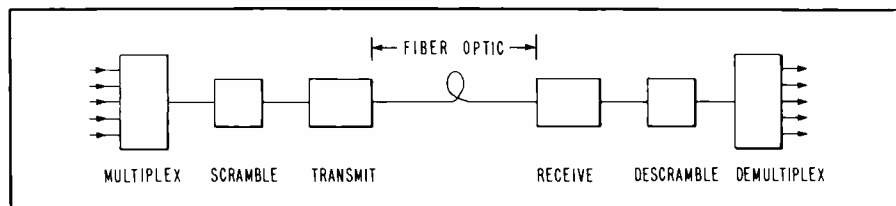


Fig. 19. Complete optical data link.

loop to the gain amplifier and to the APD. The optimal functioning of a fiber data link may involve additional circuits beyond the basic system of Fig. 15. Figure 19 shows a more complete system with two additional circuits at each end. Since the economics of fiber-optic transmission favor using the high bandwidth available rather than multiple transmission lines, parallel data are converted to a serial data stream by a multiplexer on the transmitter end. A demultiplexer on the receiver end converts back to parallel data, if required. Also, effective clock-timing recovery and

synchronization requires the data stream to be free of long time intervals without level transitions. Since the data itself may have such series of "ones" or "zeros", a scrambler circuit is used to transform it to a format that has sufficient transitions. A corresponding descrambler at the receiver end recovers the original format.

### Communication system configurations

The simple point-to-point communication system can be expanded from simplex to

duplex (one-way to two-way) by adding another fiber and transmitter-receiver pair. Alternatively, tee couplers may be used at each end of a single fiber to connect both a transmitter and a receiver.

Configurations for multi-user systems involve more alternatives. Some of these are shown in Fig. 20. The most straightforward is a point-to-point connection between each user and all the others. This becomes highly redundant as the number of users increases. A more economical approach is the data bus, in which the data circulates on a common fiber transmission line with taps for each user. Further economies are achieved with the star configuration, in which signals are distributed among all the users by a multiport coupler.

A major consideration with both bus and star configurations is the optical power wasted by coupling to users other than the desired ones (distribution loss). This consideration favors star over bus configurations, since the distribution loss goes linearly with the number of ports in a bus but logarithmically with the number of star ports. Another consideration is the cost and availability of components, since fiber-optic tees and star couplers are not yet catalog items as are fiber-to-fiber connectors.

### System performance

The performance of a data transmission link in relation to its cost is basic to component selection and overall system design. The key performance factors include: transmission distance; data-transmission rate; data error rate; system reliability; and mechanical and practical considerations.

Of these factors, the first three involve interrelationships that are described by fundamental theory. The last two are equally important, but less amenable to quantitative analysis.

Any data transmission system is ultimately limited by degradation of the fidelity of the pulses representing the transmitted information. One important form of degradation is electrical noise produced at the receiver input. Another is pulse broadening caused by the limited bandwidth of the optical fiber or the limited response speed of the optical source. Both of these phenomena can cause spurious responses when the received signal is detected to recover the original data. Figure 21 illustrates these effects.

Data detection is typically accomplished by comparing the received signal with a

reference level, called the threshold. At intervals set by the recovered clock frequency, the amplified electrical output of the photodetector is compared to the threshold level. If the signal exceeds the threshold, a binary "1" is produced, if below threshold, a "zero" is produced. Electrical noise or pulse broadening may cause a wrong decision to be made, leading to a bit error. The bit-error rate (BER) of digital transmission systems is the fraction of the total decisions that are made erroneously.

Since electrical noise has well defined statistical properties, the binary detection process described above can be analyzed. Figure 22 shows the probability distributions  $P(0)$  and  $P(1)$  for the signals being recorded at "0" or "1". The breadth of these curves reflects the signal-to-noise ratio (SNR) of the amplified signal. Shaded areas indicate the erroneous decisions. The bit-error rate is the ratio of shaded to unshaded areas.

Figure 23 shows the relationship between bit error rate and signal to noise ratio. The common benchmark for system performance is  $10^{-9}$  bit-error rate corresponding to a 21.6-dB SNR.

The modulated optical power must be sufficient to give the required BER.

Fiber attenuation of 3-dB/km is reasonable for 0.84- $\mu\text{m}$  fiber, and 0.3-dB loss for fused splices between 1-km fiber lengths. Table III shows the power budgets for the two cases. Note that use of an APD allows an extra 2 km of fiber to be used while maintaining the same power margin.

Pulse distortion can also degrade the performance of the communication system BER. Data transmission is independent of the received pulse fidelity so long as the energy is not spread from one bit position to another, but any substantial pulse spreading into adjacent bits causes a sharp increase in the BER. The BER may be improved by a compensating increase in the modulated optical power to reduce the SNR. Hence one may think of a "power penalty" to be paid for pulse distortion.

Pulse broadening is caused by dispersion in the optical fiber. Bandwidths of commercial fibers range from about 20 MHz-km to more than 1 GHz-km. The minimum required bandwidth for NRZ coded digital data is approximately one-half the data rate. Hence, the 100 MB/s data rate would require a 50-MHz bandwidth. With fiber bandwidth of 1000 MHz-km, this implies a maximum transmission length of 20 km.

System reliability may be compromised if sufficient power margin is not allowed

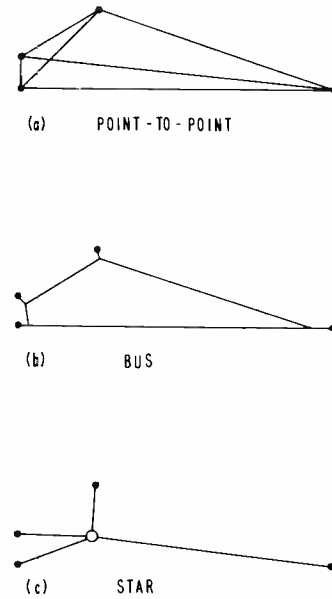


Fig. 20. Various methods for multi-user configurations of fiber-optical systems.

for. Consider Fig. 23 for a system operating at a BER of  $10^{-9}$ . A 1-dB reduction in SNR, corresponding to a 25-percent reduction in received optical power, will increase the BER to about  $5 \times 10^{-8}$ , an increase by a factor of 50. On a 10 km link of 3 dB/km fiber, a 4-percent increase in attenuation over the specified value will amount to more than 1 dB system loss. The power budget must include sufficient margin to accommodate all components tolerances and expected degradation (Table III).

Choice of components may affect system reliability in complex ways. For example, lasers are more difficult to use than LEDs, since they must be biased to a threshold current that is influenced by aging and temperature. But, they can couple over ten times as much optical power into a fiber. If this excess power eliminates the need for repeaters, the use of lasers may increase system reliability. If link lengths are sufficiently short that repeaters are not necessary using LEDs, the use of lasers may both increase costs and reduce reliability. LEDs are not suitable for very high frequency systems both because of their own modulation limits (50-300 MHz) and because of the large optical fiber dispersion (at .82-.85 $\mu\text{m}$ ) due to their wide spectral output.

### Commercial availability and future directions

Most of the fibers, emitters and detectors discussed in this article are available commercially. Fibers and emitters which are

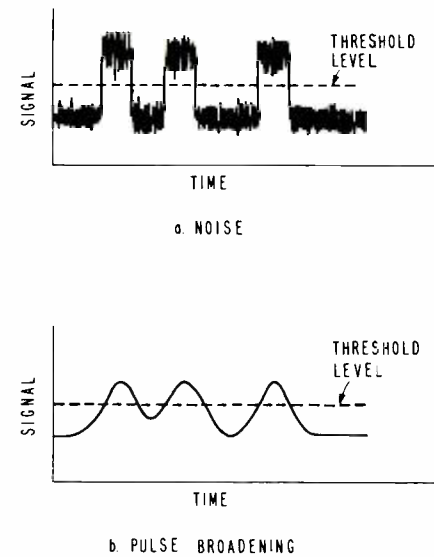


Fig. 21. Pulse degradation due to (a) noise and (b) pulse broadening.

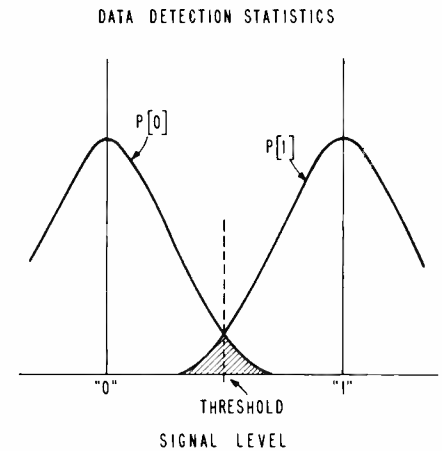


Fig. 22. Overlap between a "zero" and a "one" pulse—both of which are distributions.

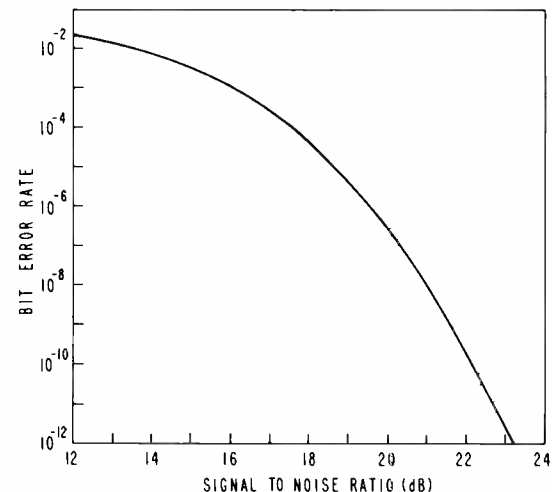
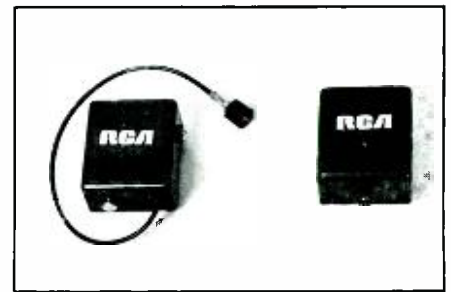


Fig. 23. Bit-error rate (BER) versus signal-to-noise ratio for a fiber optical system.

**Table III. Power budget for fiber link.**

Power/Loss	(Twelve 1-km lengths) System 1 (PIN Detector)	(Fourteen 1-km lengths) System 2 (APD)
Laser Power into Fiber	+3 dBm	+3 dBm
Splice Loss	(-3 dB) x 12 = -3.6 dB	(-3 dB) x 14 = -4.2 dB
Fiber Loss	-3dB/km x 12 km = -36 dB	-3dB/km x 14 km = -42 dB
Received Optical Power	-36.6 dBm	-43.2 dBm
Minimum Required Power	-45.6 dBm	-52.1 dBm
System Power Margin	9.0 dB	8.9 dB



**Fig. 24. RCA transmitter and receiver modules.**

optimized for 1.55- $\mu\text{m}$  operation were not commercially available when this article was written (InGaAsP lasers and detectors for 1.55  $\mu\text{m}$  have been developed at RCA Laboratories). A useful source for product information is the 1980 *Laser Focus Buying Guide*<sup>13</sup>. The Electro-Optics Division of RCA Solid State (Lancaster, Pa.) offers an impressive array of 0.85- $\mu\text{m}$ , 1.06- $\mu\text{m}$  and 1.3- $\mu\text{m}$  LEDs, 0.85- $\mu\text{m}$  and 1.3- $\mu\text{m}$  CW lasers and single-mode CW lasers for 0.82- $\mu\text{m}$  operation. High-performance silicon (for  $\lambda < 1.1 \mu\text{m}$ ) PIN photodetectors, avalanche photodiodes (APDs) and hybrid preamplifiers are available from RCA Ltd. in Montreal. Complete F/O transmitter-receiver systems are also available. Figure 24 contains a photograph of such a system, capable of handling 20 Mbit/s. An excellent reference for product and user information is the *RCA Optical Communications Product Guide* (OPT-115), available from RCA Lancaster.

Cost and availability of fibers and components varies widely—especially since much of the early demand is for custom-designed prototype systems. Emitter costs vary from less than \$10 for low-cost LEDs to over \$2000 for special types of CW lasers. Similarly, fiber costs range from well under a dollar/m for high-loss ( $>1000$  dB/km) plastic fiber to several dollars/m for low-loss (1-3 dB/km) silica fibers. One thing is certain—costs are sure to tumble as demand increases and volume production takes place.

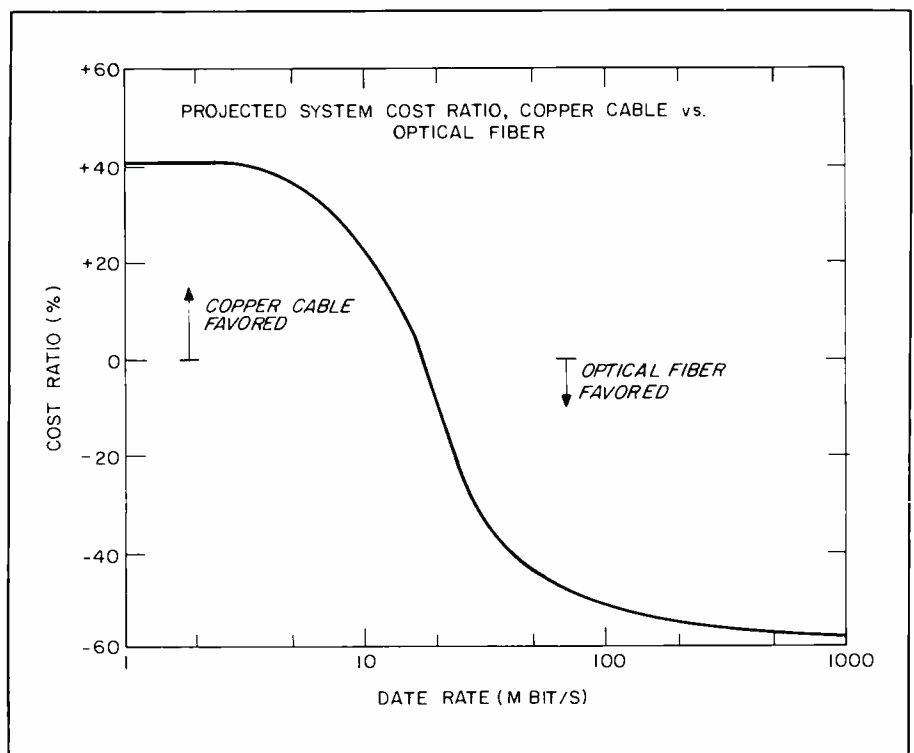
Cost consideration involves all aspects of systems, including components, fiber, cable, repeaters and terminals. Projections of system costs, considering their elements, show that fiber is favored at high data rates, where their superior performance reduces or eliminates repeaters. A comparison between projected fiber and copper cable system cost shown in Fig. 25 gives the crossover between these technologies as 10 to 20 Mbit/s.

According to a Gnostic Concepts report, fiber optics will grow from a present \$145

million U.S. business this year to a \$3.5 billion in 1990. Twenty percent of this is in planning, 35 percent in interface equipment and 45 percent in cable systems. Telecommunications comprises the largest share, ~40 percent, with the military at ~20 percent and such other applications like computers, CATV and instruments all taking fractions less than 10 percent. Fiber-optical communications represent another advance in information processing towards sending larger amounts of information at faster rates.

## References

- Mimms, F.W., III, *Optics News*, Vol. 6, p. 8 (1980).
- Kao, K.C. and Hockham, G.A., *Proc. IEEE*, Vol. 113, p. 1151 (1966).
- Edahiro, T., Kawachi, M. and Suslo, S., *Electron. Letters*, Vol. 16, p. 478 (1980).
- Elion, G.R. and Elion, H.A., *Fiber Optics in Communication Systems*, Marcel Dekker, Inc., N.Y. (1978).
- Gallawa, R.L., *Users' Manual for Optical Waveguide Communications*, Information Gatekeepers, Inc., Brookline, Mass. (1979).
- Botez, D., *Proc. IEEE*, Vol. 68, p. 689 (1980).
- Olsen, G.H., *SPIE Proceedings on Fiber Optics for Communications and Control*, Paper 224-17 (April, 1980).
- Kressel, H. and Butler, J.K., *Semiconductor Lasers and Heterojunction LEDs*, Academic Press, N.Y. (1978).
- Hurwitz, C.E., *SPIE Proceedings on Fiber Optics for Communications and Control*, Paper 224-19 (April, 1980).
- Eitenberg, M. and Kressel, H., *IEEE J. Quantum Electronics*, QE-16, p. 186 (1980).
- Yamakoshi, S., Abe, M., Komiya, S. and Toyama, Y., *Technical Digest - International Electron Services Meeting (IEDM)*, IEEE Press, p. 122 (1979).
- Olsen, G.H., Nuese, C.J. and Ettenberg, M., *IEEE J. Quantum Electronics*, QE-15, p. 688 (1979).
- 1980 *Laser Focus Buyer's Guide*, Advanced Technology Publications, Inc., Newton, Mass.



**Fig. 25. Cost comparison of copper cable and optical fiber systems versus data rate.**

## Glossary

**avalanche photodiode (APD):** a semiconductor photodiode that achieves gains of 10-200 by the multiplication of carriers via impact ionization (avalanche breakdown) at high reverse bias.

**bandwidth (B):** the frequency response or data rate of a fiber or device, usually referred to as the high frequency at which the response amplitude has dropped by a factor of 2 (3 dB).

**bit-error rate (BER):** the fraction of bits (or information pulses) that are received erroneously. A minimum figure of  $10^{-9}$  is often specified for communication systems.

**dark current:** any current that flows across a reverse biased P/N junction in the absence of a light signal.

**decibel (dB):** a unit used to describe gain or loss, usually expressed as  $d B = 10 \log (P_2 / P_1)$ . Another unit used to express power levels relative to 1 mW, is  $d Bm = 10 \log P_2 / 10^{-3}$ . Thus, -10 dBm refers to a 0.1 mW power level.

**detectivity (D):** the reciprocal of noise equivalent power ( $D = 1 / NEP$ ). Another term,  $D^*$ , is used to normalize  $D$  against detector area and bandwidth, that is,  $D^* = D(A \bullet B)^{1/2}$ .

**dispersion:** the change in refractive index with wavelength. Dispersion in optical fibers causes pulse spreading that limits frequency response.

**noise equivalent power (NEP):** the power, incident upon a detector, that gives a signal to noise ratio of one. The bandwidth

and incident wavelength must also be specified. Units are typically  $\text{watts/Hz}^{1/2}$ . NEP is a measure of the minimum detectable signal for a detector.

**numerical aperture (NA):** a number specifying the light-gathering ability of a fiber. The maximum angle of incident radiation at which a fiber will accept and propagate light is given as  $\sin \theta_m = NA$ .

**PIN detector:** a photodetector that converts light to charge in an intrinsic (I) region between P and N-type semiconductor layers and collects the electric field between the layers.

**responsivity:** the ratio of output current (or voltage) of a detector to the input flux in watts (or lumens).

**rise time ( $\tau_r$ ):** the time for a device to increase from 10 percent to 90 percent of its peak output value, assuming a step-function input.

**single-mode:** term used to connote the presence of only one particular distribution of the optical electromagnetic field. Modes in semiconductor lasers are referred to as *lateral* (parallel to the laser cavity), *transverse* (perpendicular to the cavity) and *longitudinal* (along direction of propagation). Thus, a single lateral-mode laser has only one single lobe of light which may contain several wavelengths, whereas a single longitudinal-mode laser has only a single-frequency wavelength. Single-mode fibers propagate only one mode.

**Michael Ettenberg** is Head of the Optoelectronics Devices and Systems. He joined RCA Laboratories in 1969, and has made major contributions in the area of III-V compounds and devices. In the area of material synthesis, he was codeveloper of the multibin "thin-melt" liquid-phase epitaxial technique used widely for the growth of multiple-layer heterojunction structures. He has contributed to the development of CW injection lasers with studies leading to the reductions in laser threshold and the development of dielectric facet coatings. His work on reliability of laser diodes has included high-temperature degradation studies, reduction of mirror damage by facet coating, the study of the effect of growth conditions on long-term operating reliability, and some of the first studies of reliability in long-wavelength electroluminescent devices. Dr. Ettenberg has authored or coauthored more than 80 papers on his work and has been awarded 20 patents.

Contact him at:  
**RCA Laboratories**  
**Princeton, N.J.**  
**TACNET: 226-3149**

**Donald Channin** is Member of Technical Staff at RCA Laboratories. On joining RCA in 1970, he worked on acousto-optic laser light deflection and modulation. Subsequent work on optical waveguides led to the development of several electro-optic waveguide devices and the analysis of scattering phenomena. His work on liquid crystals has included the development of an integrated-circuit inspection process and a new technique for scanned displays. More recently at RCA Laboratories he has been doing research on modulation and high-frequency effects in injection lasers. Dr. Channin received two RCA Laboratories Outstanding Achievement Awards, one in 1973 and the other in 1975. He authored approximately 15 technical publications and holds nine U.S. patents.

Contact him at:  
**RCA Laboratories**  
**Princeton, N.J.**  
**TACNET: 226-2383**

**Gregory Olsen**, appointed Research Leader in the Optoelectronics Research group in 1980, joined RCA Laboratories in 1972. He developed advanced vapor phase epitaxial growth techniques and performed extensive characterization studies on III-V semiconducting compounds. His fundamental studies of crystal defects have contributed to marked improvements in photoemissive devices, lasers and LEDs. Dr. Olsen has published over 50 papers in the above fields, holds five U.S. patents and recently coauthored a book on semiconductor crystal growth. In 1978 he received an RCA Outstanding Achievement Award for his research.

Contact him at:  
**RCA Laboratories**  
**Princeton, N.J.**  
**TACNET: 226-2593**



From left to right, Donald Channin, Michael Ettenberg and Gregory Olsen.

# Fiber-optic-cable data network

*Fiber-optic-cable can be used in a flexible, reliable command and control system for carrying messages.*

---

**Abstract:** *A flexible, reliable command and control system concept has been developed and validated. This system can be a reliable message transport medium for many users provided the user-throughput requirements are compatible with the limitations of a flood routing system. The microprocessor design used within each node simplifies changes in system parameters to adapt to specific system requirements. Fiber optics can provide cost and performance benefits; but the environmental limitations of present day devices should be well understood before this type of transmission medium is used.*

---

During 1979, Government Communications Systems' (GCS) digital switching group undertook the development of a reliable command and control cable data network (CDN). The group studied a number of cable networks. They chose the fiber-optic-cable data network described in this article because the system was most readily adaptable to changes in network requirements and configuration. The network consists of multiple, uniform, communication nodes. The communication node is a microprocessor-based digital controller that handles the timing, formatting, transmission and reception of network data traffic. These nodes can be connected to other nodes in a somewhat random fashion, but no single node can be connected to more than three others. The network data traffic depends on the specific system application that the network will support. For the MX program, this traffic would have included such commands as missile launch, missile arm, key change, status interrogations, etc.

The group successfully validated the

system concept by developing and testing a system prototype. The prototype configuration, consisting of three communication nodes interconnected by kilometer-long fiber-links, was built as part of a 1979 IR&D project and demonstrated in early 1980. Although the system was originally targeted for the MX missile system program, the microprocessor in each node permits adaptation of this system to other applications. The microprocessor in the node performs all the logical functions required to validate, route, and manipulate message traffic, and provides the basis for all timing decisions involved in transmission and retransmission.

The key benefits of the communication system are:

- The communications nodes' uniformity and simplicity;
- The nodes' adaptability to changes in message addressing, format, size and, to some extent, timing;
- Complete nodal self-test, with a failed-node bypass-feature;
- Very high communications reliability;
- Minimal disruption (node or link failures) of network communications;
- Data broadcast from any node to all or any subgroup of network nodes;
- Communication nodes easily added to the net;
- Distributed timing—no central clock; and
- Electromagnetic pulse/electromagnetic interference (EMP/EMI) protection.

The key limitations of the system are:

- Only one or two selected nodes can generate most of the traffic. Other nodes can only send one message burst per epoch. "Message burst" implies that the data in the message is spurted out at the transmit time. There is no basic difference

in this instance in the usage of the word message and the term data traffic previously used. The epoch is a programmable time interval that ranges from seconds to minutes, depending on the selected size of the message burst per node and the number of nodes in the network. The epoch represents the round robin period wherein each node sends its message. For example, if 1000 nodes each send a message burst 16 milliseconds (ms) apart, then the epoch time is approximately 16 seconds. The size of the message burst is only a factor in that it affects the spacing requirements between bursts from each node (in this instance the 16 millisecond interval is based on a message burst size of approximately 1 ms). The epoch is not at all related to the propagation time of the message. A system of 100 nodes that employs a short message size (200 bits) would result in an epoch only a few seconds long, thus providing nearly real-time communications from all nodes.

- The system employs a fixed message length. This length can vary between systems, but is preselected for any given system. The system user can, however, pad short messages to the standard length and break up long messages into multiple, standard-sized messages.

## System description

### Connectivity

The cable data network (CDN) connection scheme, shown in Fig. 1, applies to any topography. Full-duplex (two-fiber) fiber-optic cable connects each node to two or three neighboring nodes. This forms a loosely connected grid designed to achieve required network reliability and survivability with minimum cross-connects. The nodes are uniform except that some nodes—command/control nodes or "control centers"—perform certain software functions over and above those functions assigned to subsidiary nodes.

### Routing

A flood-routing protocol is used wherein each node retransmits to adjacent nodes all nonduplicative, authentic, error-free messages received. Each message propagates from the source node (any node originating the message) to all other nodes via all available cable paths. This multiple propagation path increases the probability that the message will be received. Also, the



multiple propagation paths, in conjunction with the flood-routing protocol, increase the likelihood that a transmitted message will reach its destination even if many paths are disrupted as long as a single path between source and destination survives. The main disadvantage of flood routing is that duplicate messages are transmitted and thereby the total traffic handling capacity of the network is reduced.

### System timing

The processing capacity of each node and the speed of the data-reception circuitry at each node are the primary limits on the network's traffic capacity. The most recent nodal design limits the message-burst data rate to 0.5 megabit and the total message-generation rate to approximately 250 messages per second.

One can allocate this total message handling capacity among nodes in the system. The software defines a node as either a subsidiary node permitted to generate only the one scheduled message per epoch or as a center that can generate a message as often as every 16 ms. A site-address plug differentiates the node type. The site address plug is a physical wired plug whose wiring arrangement can be electronically translated into a unique address code that identifies the site and indicates whether the node is a command/control type or subsidiary type. It looks like an ordinary cable connector plug. Relatively simple changes in the node software would permit a different allocation of the system capacity.

Message timing of the cable data network is shown in Fig. 2. The time of day (TOD) is distributed from a designated system control node at the start of each epoch. No other message traffic is allowed by any node until the TOD message has propagated through the network. After the TOD is sent, each node transmits in a preassigned sequence. Each of the nodes are numbered sequentially and the nodes transmit in sequential order based on their assigned addresses. Transmissions are approximately 16-ms apart.

Each node, including the control node, sends one fixed-size scheduled message per epoch. The node buffers the message until its assigned transmit time slot within the epoch, at which time the message is transmitted as a burst and propagated to all other network nodes. The command/control node, in addition to its scheduled message, can send unscheduled messages at will.

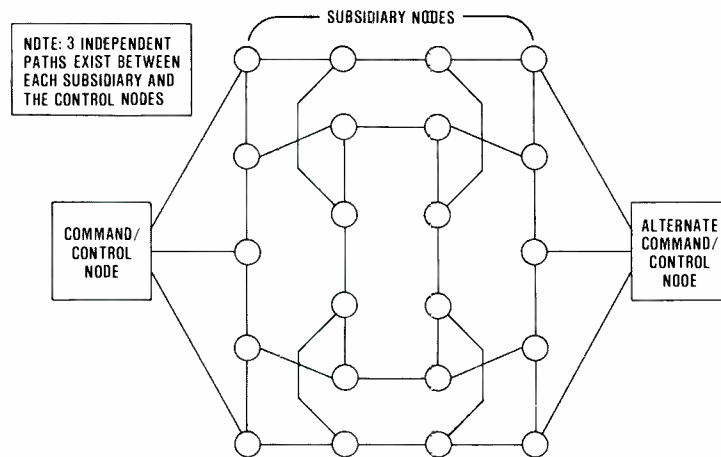


Fig. 1. Typical net connectivity.

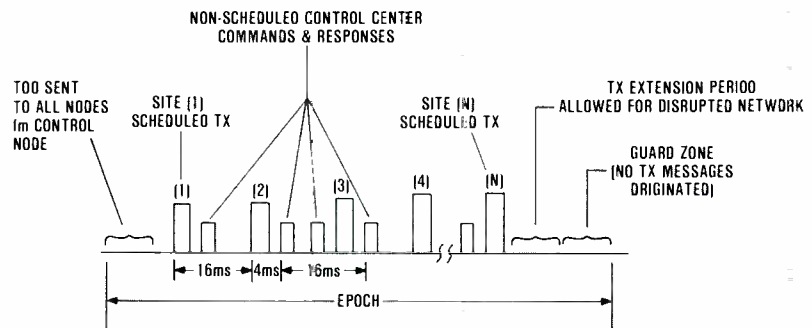


Fig. 2. Network timing.

Interleaved between scheduled transmissions are transmissions originated by (or responding to) command/control nodes. Each control node can send messages as often as every 16 ms. Subsidiary nodes may respond to interrogations received by command/control nodes without waiting for their normal send-time slot. Interrogations are specific message types generated by control nodes for the purpose of requesting (or interrogating) data from subsidiary nodes. The interrogating control node must stop sending, however, to allow the responding node to occupy its allocated time slot. Although the message transmission is controlled at the message's point of origin, there is no special control of the message as it traverses the network. This is not a rigid time-division system. Messages are permitted to clash (arrive simultaneously at a node). The node accepts and buffers all messages received simultaneously from adjacent nodes. The buffered messages are processed and those that pass required checks are retransmitted. But a 4-ms minimum delay is imposed on successive transmissions (or retransmissions) from any node to assure that receiving nodes

have time to buffer and process all incoming data. The stated transmission rules control the volume and distribution of nodal traffic, thereby minimizing the buffering required at a node. In a flood-routing protocol valid messages are retransmitted on all outgoing lines except the incoming line. The process described is supporting this protocol.

The guard zone at the end of each epoch, wherein no new messages are generated, permits all messages to complete their journey through the network. The guard zone also allows all node message queues to empty in preparation for the next epoch.

### Message format

The message format is shown in Fig. 3. The message has four fields: sync, header, data and cyclic-redundancy-check (CRC) character. The eight-bit-long sync field indicates the start of a message. All messages use the same sync character. The header field controls retransmission and reception of the message. The header has an authentication code that prevents messages generated outside the latest

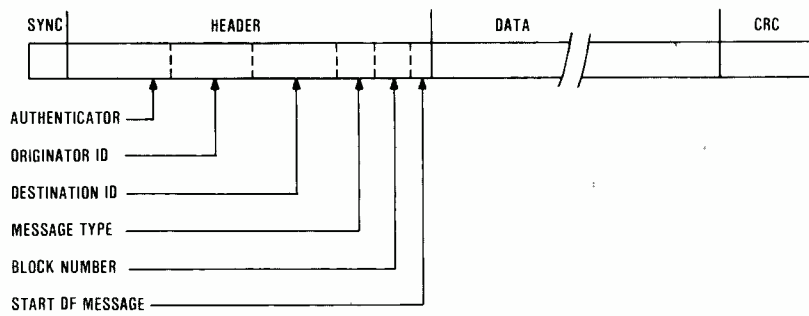


Fig. 3. Message format.

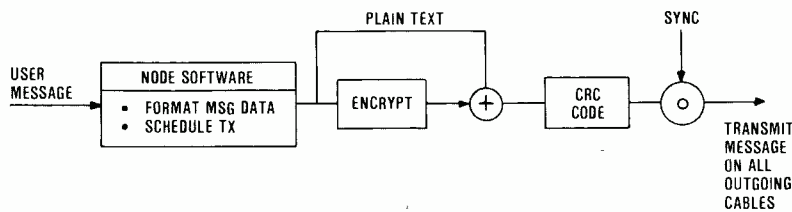


Fig. 4. Transmit message flow.

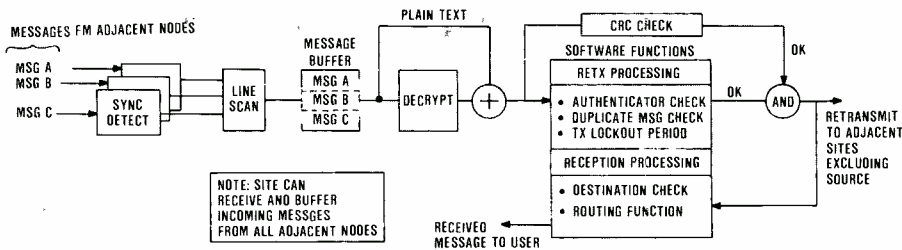


Fig. 5. Retransmission and reception message flow.

epoch from being propagated. This authentication code is changed at all nodes at the beginning of each epoch and can be a code derived from TOD transmissions. The next field in the header is the originator code indicating the source of the message. The destination-identification field is next in the header and can indicate an individual node, all nodes, or a subset of the nodes as a destination.

The rest of the header consists of message-type, block-number, and start-of-message fields. Message type indicates the type of message such as launch message, status message, etc. This field indicates how the message is to be processed. Start-of-message indicates block-one of a message. Block number indicates the message-sequence number from a given source. The sequence number is reset at the beginning of the epoch and applies only to control nodes since only they can originate multiple messages during a single epoch. The data field contains the text, or content,

of the message. The final field is the CRC character, used to detect errors in transmission. The user supplies the destination, message-type and start-of-message fields. The communications node inserts the source-address, block-number, authenticator and CRC fields.

### Message transmit flow

Figure 4 shows the message-transmit flow within the node. A message received for transmission is formatted with the appropriate header. If the message is the scheduled transmission (designated by message type), the node must first await reception of the scheduled transmission from the lower-numbered node. Nodes are numbered sequentially (1, 2, 3, 4, 5). Node 5, for example, transmits its scheduled transmission after recovering the scheduled transmission from node 4.

Normally, the node transmits 16 ms after receiving the scheduled transmission of the previous node, however, a lookup\* is provided to instruct the node how long to delay transmission if the scheduled transmissions from previous nodes are missed. The node is rescheduled based on the last correct traffic received. The transmission delay permits messages to arrive late without interference. In a degraded network where nodes are down, messages can take a circuitous path to reach the next functioning node. Only control nodes can send nonscheduled transmissions. These are sent immediately, provided at least 4 ms have elapsed since the node has last transmitted or retransmitted a message.

The message block may be encrypted prior to transmission. Encryption implies scrambling and coding of the message so that it is unrecognizable by an enemy monitoring the transmission line. Plain text refers to traffic that does not require encryption. The node then appends sync (to the beginning) and CRC (to the end) as the message is transmitted.

### Message retransmit flow

Message retransmission and reception flow is depicted in Fig. 5. Message-receive lines are normally open and looking for message sync. When sync is found, the message is stored in a buffer until the microprocessor can process it. The message delivered to the user is not encrypted. As noted in Fig. 5, encrypted messages received are decrypted prior to processing. But the first message received is processed as the header is received, to reduce propagation delay. The microprocessor checks the authenticator to assure that the message is properly in the latest epoch. The microprocessor logs each scheduled message to assure that it receives one scheduled message per epoch from each node. Duplicates are discarded. Nonscheduled messages are checked in by source and block number. Duplicates (old block numbers) are discarded.

If all software checks are "go" and the message CRC (CRC check performed by hardware) is correct, the message is retransmitted. Performance of the CRC check in hardware allows the message to be cleared for retransmission immediately upon receipt of the last bit in the message,

\*The lookup is a table in the microprocessor that provides the delay time to be implemented. The item in the table is indexed by the last scheduled traffic correctly received.

thus minimizing the node-propagation delay. Only authentic, nonduplicative, error-free messages are retransmitted. Only these messages undergo further processing within the node. If the message destination matches the node, the node will deliver the message to the local user. A node can receive and buffer simultaneous traffic from up to three adjacent nodes using a fast line scan so that traffic from all lines are stored without losing bits from any of the input lines. The first message is processed and retransmitted immediately after the message burst is received. Other simultaneous traffic is normally a message duplicate that is discarded. Traffic received simultaneously on different lines can, at times, be different messages (not duplicates). In this instance, the second message processed will be retransmitted 4-ms after the first message.

### Transmission lines

Although the selected concept and the developed breadboard use fiber-optic lines to interconnect nodes, any wideband-transmission medium suffices. The advantages of fiber optics are the wide bandwidth, low bit-error rates (BERs) achievable and elimination of EMI/EMP problems. The low BER, the error detection and the alternate paths offered by this system concept result in an extremely low probability that a message-in-error will go undetected and a very high probability that the correct message will be delivered. The node design permits substitution of different types of fiber-optic line terminators (FOLTs) via a plug-in module to match the drive power and the reception sensitivity with link distances. Figure 6 indicates the range of currently available FOLTs as a function of data rate when employing a low-loss (e.g. 6dB/km) cable.

It was found that the fiber optic links are reliable once connected, but after disconnection they must be adjusted to get them properly reconnected. Furthermore, the fiber-optic connectors (Siacor) work as mating pairs but are not interchangeable. One can measure the performance of the link and isolate which end of a link has failed only if the fiber-optic digital receiver has the received analog signal available. Although drivers and receivers are available in small quantities, the devices have inconsistent quality. Very few available devices meet military specifications, and uniform standards for device quality control and testing do not exist.

### Failed system operation

A node failure in the network does not seriously affect communications between other network nodes since these nodes will communicate by any available route and circumvent the failed node. Multiple node failures might isolate a functioning node, but a unique design feature to prevent this from occurring was incorporated and tested. This feature — the bypass feature — causes the failed node to short-circuit itself and act as a repeater. The bypass feature is only indirectly related to the flood protocol. The bypass feature permits traffic to pass through a failed node, thus keeping the communication path open. It is true that other paths usually exist, so that even if the path were not available, traffic would still reach its intended destination. But in cases of widespread network damage or multiple node failures, the bypass feature tends to prevent loss of all paths to a healthy node.

The bypass function is designed to be fail safe. A periodic "keep alive" signal from the node microprocessor inhibits the function, while failure of the microprocessor places the node in the bypass mode. Furthermore, at the end of each epoch, there is a silent period with no external traffic present. During this period, the microprocessor performs node loopback and link tests designed to detect node failures. If critical failures are detected, the microprocessor reports the failure and then initiates the bypass. Node failures are always detected by the system control-

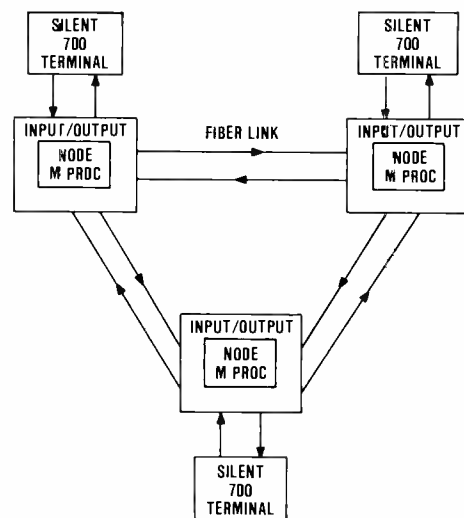


Fig. 6. Performance characteristics of various fiber-optic line terminals (FOLTs) for 6 dB/km cable attenuation and  $10^{-9}$  bit-error rate.

center nodes, either by direct receipt of failure reports or by lack of receipt of the scheduled transmission from the node.

### Prototype

A prototype of the above system was built to demonstrate some of the network features. The prototype consists of three nodes connected by one-kilometer lengths of full-duplex fiber-optic cable (Fig. 7). Each node is identical in both hardware and software. The nodes are differentiated by address switches set to the node's originator code. These switches are read by

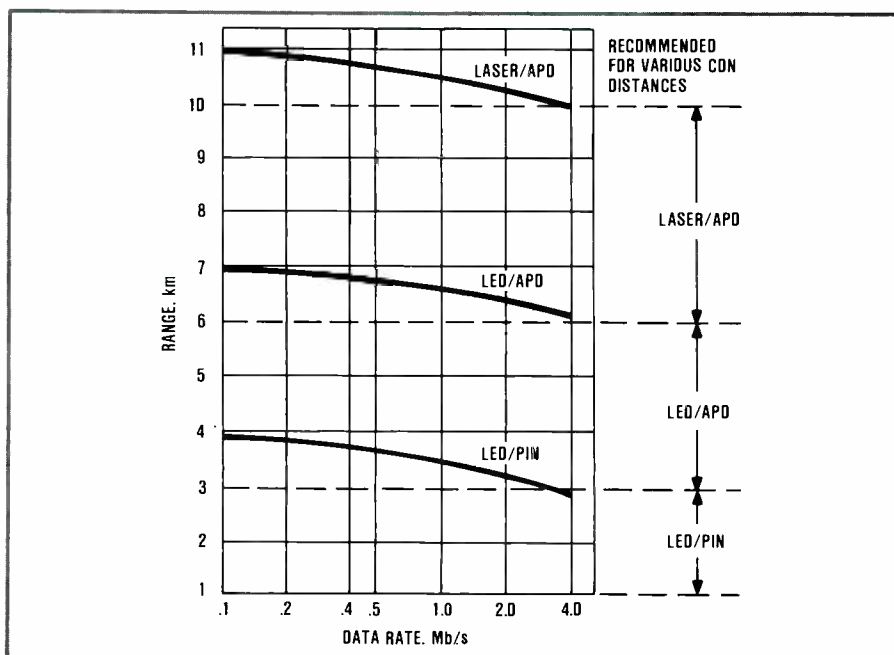


Fig. 7. Three-node-cable-data network prototype.



**Fig. 8. The lab set-up of the three-node CDN prototype RCA PC80 0227 CS-2.**

the microprocessor during the power-up routine. A TMS 9900 microprocessor with about 250 chips for specialized logic was used. The TMS 9900 is a 16-bit machine with separate address and data busses, and

serial I/O. For military applications, a Red/Black division was included in the design to facilitate tempest isolation and encryption/decryption of the message traffic. A "red/black division" refers to a

physical separation of the equipment which handles secure traffic and equipment which handles non-secure traffic. Encrypted traffic is considered non-secure, or black, and decrypted traffic is considered secure, or red. Tempest isolation refers to specific hardware design features which prevent compromising emanations, such as radiated signals, from coupling the red area traffic to the black area.

The prototype system demonstrated transmission and retransmission of TOD, scheduled messages and control-node messages. Filtering of duplicate, non-authentic, and error messages was demonstrated. The system's immunity to cable breaks, and the bypass feature of the nodes were also demonstrated. Figure 8 is a photograph of the laboratory setup.



**Authors (left to right) Dale Deutscher, Marty Mann, Bernie Patrusky and Joe Sergi.**

**Dale Deutscher** joined the RCA Government Communications Division in 1978 as a design engineer in the Digital Communications area. Initially he worked on the Automatic Data Processing Telecommunications (ADPT) testbed program, where he was assigned to write test and maintenance programs for the Host processor, a unit that functioned as a node in a communications network. Afterwards, he was assigned to the hardware design of the Cable Termination Equipment prototype described in this paper. He then worked on hardware design of the Mobile Subscriber Central (MSC) prototype before going to work for RCA 'SelectaVision' VideoDisc in Indianapolis, where he is assigned to Test Engineering.

Contact him at:  
**RCA 'SelectaVision' VideoDisc**  
**Indianapolis, Ind.**  
**TACNET: 426-3201**

**Marty Mann** is a Unit Manager in the Government Communication System Division specializing in the area of Digital Communications. He is supervising work on enhancements to the Automatic Data Processing Telecommunications, ADPT system for the Air Force and the development of a Mobile Subscriber Central for the

Mobile Subscriber Equipment Testbed. Prior to his managing the Cable Terminal Equipment project, he worked as a project engineer and then Unit Manager on the ADPT Testbed. This system integrated circuit, message and packet switching under control of a single processor. He was responsible for all the hardware designed on the testbed and was awarded a patent on one of the unique front-end units designed and developed for this system.

Contact him at:  
**Government Communications Systems**  
**Camden, N.J.**  
**TACNET: 222-2012**

**Bernard Patrusky**, Manager, Digital Technology Government Communication Systems Division, has been with RCA for twenty-seven years. He has worked on communication systems; computer architecture; and packet, message and circuit switching. Recently he has had system responsibility for the Automated Data Processing Telecommunications (ADPT) program. During the MX proposal he led the proposal team which developed the Cable Data Network concept described in this article. He was the technical director of the Integrated Radio Room program from 1973-1975. In the early seventies he was a Unit

Manager on the Apollo Ranging Program. Prior to that he was a project leader on the Minuteman and Autodin programs.

Contact him at:  
**Government Communications Systems**  
**Camden, N.J.**  
**TACNET: 222-2071**

**Joe Sergi** joined the RCA Government Communications Systems Division in 1977 as a design engineer in the Digital Communications area. Initially he worked on the Automatic Data Processing Telecommunications (ADPT) Testbed program where he was assigned to enhance the Buffer Matrix (BMX), a unit that automatically assigned buffer space and trunk time slots on a demand access basis. He also wrote several Test and Maintenance programs for the testbed on its central processor an Interdata 8/32. Afterwards, he was assigned to the hardware design of the Cable Termination Equipment prototype described in this paper.

Presently, he is involved in the hardware and software design of the Mobile Subscriber Central (MSC) prototype.

Contact him at:  
**Government Communications Systems**  
**Camden, N.J.**  
**TACNET: 222-2687**

# Evolutionary factors in telephone terminal technology

*The telecommunications industry is changing in response to new technology, but the process is slow. Sixty years of accumulated inertia must be overcome.*

---

**Abstract:** *Although the telephone industry is one of the leaders in technology, its past isolation from the competitive environments has delayed the full benefits of that technology. Regulatory and legal action has allowed open access to the telephone network and has created a new frontier for technological innovation. New rules and standards are just now being developed. Opportunities are almost unlimited for engineers who wish to participate.*

---

The telephone set on your desk is one of the most effective communication devices ever created by man, perhaps second only to the printing press. But it is the telephone systems behind that telephone set that make it such an effective device. Systems is plural because the telephone industry is a number of interactive systems or systems within systems. It is that mostly unseen organization of equipment, regulatory rules, business concepts, and technology behind the telephone set that this article discusses. I do not intend to describe in any depth each segment of the telephone industry, but I will discuss the ways in which their interrelationships affect the development and the application of new technology.

I will also look at how the application of old and new technology has affected the industry and the end user—the customer.

## Four views of the telephone industry

### Organization of the business

If we could take a step or two back and look at the telephone industry in perspective, we would see a few large holding companies, the AT&T, for example. There would also be several small holding companies, such as Mid Continent, and many small privately held operating companies, such as the Wayside Telephone Company. If we were to look a little closer, we would see that the large holding company consists of a research group, a manufacturing group, a long lines group, and several other groups called operating companies to provide telephone (voice and data) communication service to the customer.

Generally speaking, there are about twenty telephone holding companies and about 1,488 independent operating companies. The number of independent operating companies is decreasing—there is a tendency for the big ones to buy the little ones. For the same reason, a few of the holding companies are getting larger.

### Legislative and regulatory effects

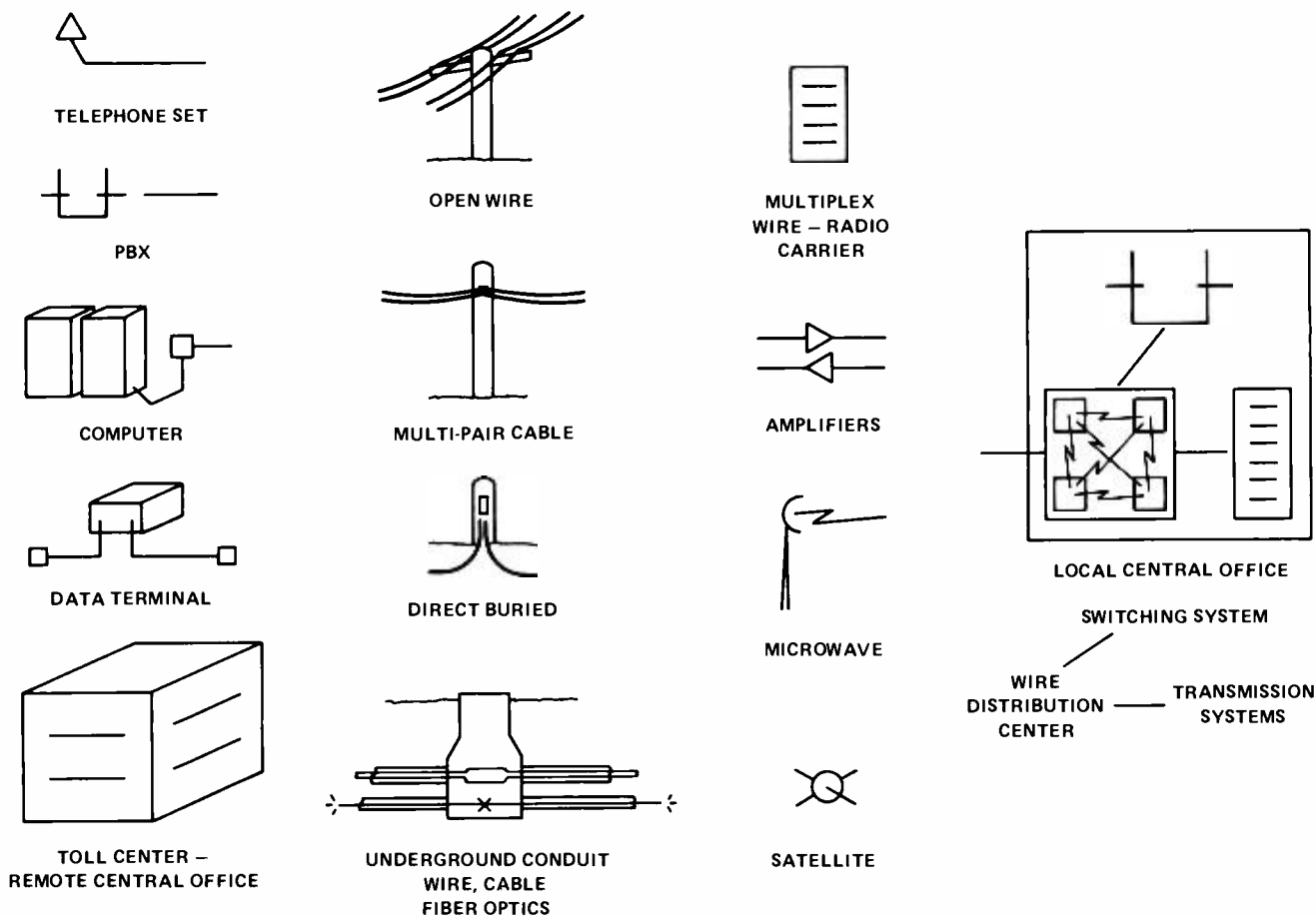
If we look at the telephone industry from a different angle—the legislative and regulatory segment—we again see large components such as the federal and state legislative laws. These establish and define to varying degrees the functions of

telephone regulatory agencies. For the most part these laws stem from the Communication Act of 1934, which established the Federal Communications Commission (FCC) and formed the basis for the state laws. The state laws were used to establish the state commissions.

One of the functions of the FCC is to monitor and regulate the interstate activities of telephone common carriers. Note that the FCC does not regulate the entire telephone industry. The FCC does have some jurisdiction over operating telephone company matters where systems are used in both intrastate and interstate service.

The state commissions have limited regulatory control over intrastate activities and tariffs of telephone common carriers. Of course, there are always conflicts between federal and state regulation interests. These differing interests have, in the recent past, resulted in real cost impacts and delays in realizing the benefits of new technologies in the telephone industry. The competitive thrust of recent FCC, court and federal legislative proposals have not been received with enthusiasm by many state commissions. Many of them do not appear to recognize the relationship between a competitive environment and the benefits of the application of new technology.

Legislative acts, regulatory rules, and court decisions have played major roles in the telephone industry's response to the application of new technologies. The monopoly status given in the past to the



**Fig. 1. The physical equipment consists of terminal equipments and remote switching offices which are connected via distribution and transmission facilities to local central offices. It is the end terminals and distribution facilities between major switching offices where competition has encouraged the application of new technology.**

telephone operating companies has had the net effect of impeding the implementation of new technologies in some segments of the industry.

Although the FCC and state commissions oversee and regulate the interstate and intrastate service of the operating telephone companies, they do not have authority over the other segments of the industry. There is nothing in the regulatory sector that specifically restricts the application of new technology. The restriction of implementation of new technology in some parts of the telephone industry has been a business decision. We will see that in the recent past significant changes have taken place.

There has been no opportunity for customers to influence the pace at which new technology was applied. They were denied by law the opportunity to connect state-of-the-art equipment, systems or devices to the telephone network. This situation has changed in the past ten years.

Taking a closer look at the industry, we see the smaller components of this segment. These smaller components are the tariff documents that are part of the end products created by the laws, regulations

and court decisions. The tariffs are not unlike a cookbook and menu all in one. These documents list what equipment and services can be offered, how they are to be used, who can use the installed equipment, the rental fees and installation charges, and many other things. The tariffs are the result, for the most part, of an operating company's proposals filed with the appropriate commission.

Prior to 1969 the tariffs dictated, with few exceptions, the technology actually used by the customer. If it is not in the tariff, it cannot be provided. There are exceptions under which special assemblies may be provided. The FCC and a few state commissions have in their rules specified accounting procedures, technical requirements and other regulations that are made part of the telephone company tariffs.

### *Physical equipment and systems*

There is yet another — a third — aspect of the telephone industry. This is the physical system. The hardware (software is included also) grouping of the physical equipment is

of special interest. It is here that the interrelationship and interaction of our first picture, the company types, and the second picture, the legislative/regulatory, begin to demonstrate their different effects on the application of new technology.

A quick look at Fig. 1 gives an overview of that physical configuration, showing four general types of equipment:

1. Customer equipment or station terminal and switching systems.
2. Customer cable distribution systems and related loop transmission treatment equipments.
3. Central office equipment, including the central office switching machines of several types, transmission systems that terminate customer loop and interoffice trunking systems, and other central office support systems, such as power, billing and testing facilities.
4. Interoffice trunk distribution systems. These are the cable and open-wire plant, multi-channel carrier systems such as wire carriers, microwave, satellite, and now the use of fiber optics. Figure 2 shows the hierarchy of the public telephone networks. Not shown is the

private line segment of the telephone system. Private line systems are tailored to the specific operating requirements of the end user. Except for special terminal equipment such as data modems and a limited number of switching systems, the equipment used for private line service is the same as for the public telephone network.

The operating companies, large and small, provide end-terminal equipment, customer loop-distribution systems and servicing (end) central offices. The larger companies also provide, depending on their size, higher hierarchy offices and the associated interoffice trunking facilities. The Long Lines segment of AT&T provides a major fraction of the interstate, intercompany transmission and toll switching systems.

The growth in the telephone industry over the past several decades has been significant. It is in the area of transmission systems growth over the past twenty years that most of the new technology has been centered. We have gone from the simple analog voice transmission to analog multiplexing, time-division and pulse-code multiplexing. Now fiber-optics systems are being installed. The application of new technologies is in the new additions and growth areas of the transmission and distribution systems. There has not yet been a significant amount of replacement of the old with the new.

Look at that telephone set on your desk. A high percentage of you will see about the same set as was there twenty or thirty years ago. There has been little change. And if you go to the telephone equipment room or the central office you will, with a few exceptions, see the same switching technology that has been used for the past thirty or more years. Figure 3 shows the crossbar switch. This type of switching is known as common control switching, and it is the major switching technology in use today. These machines have been the workhorses in the telephone systems. They have all the advantages of electromechanical technology and few of the disadvantages.

Common control allows functions not possible in the early step-by-step equipment. They are: storage, conversion, integration, programming, scanning, allotting and, of course, multiplication. The crossbar switch itself is not a new application of electromechanical technology. The earliest versions were developed around 1915 by Western Electric. The present crossbar selector is credited to the Swedish engineer,

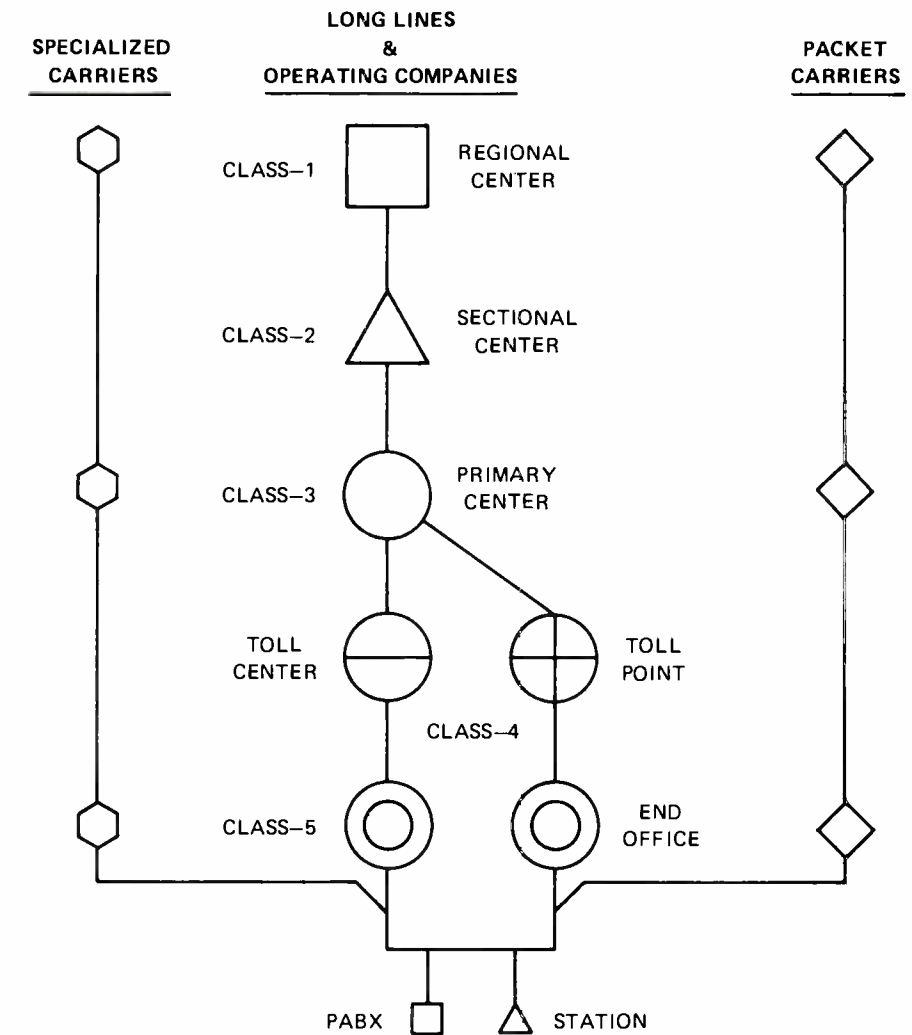


Fig. 2. The telephone network hierarchy is compared with tandem switching or processing modes of the newer competitive voice and data carriers.

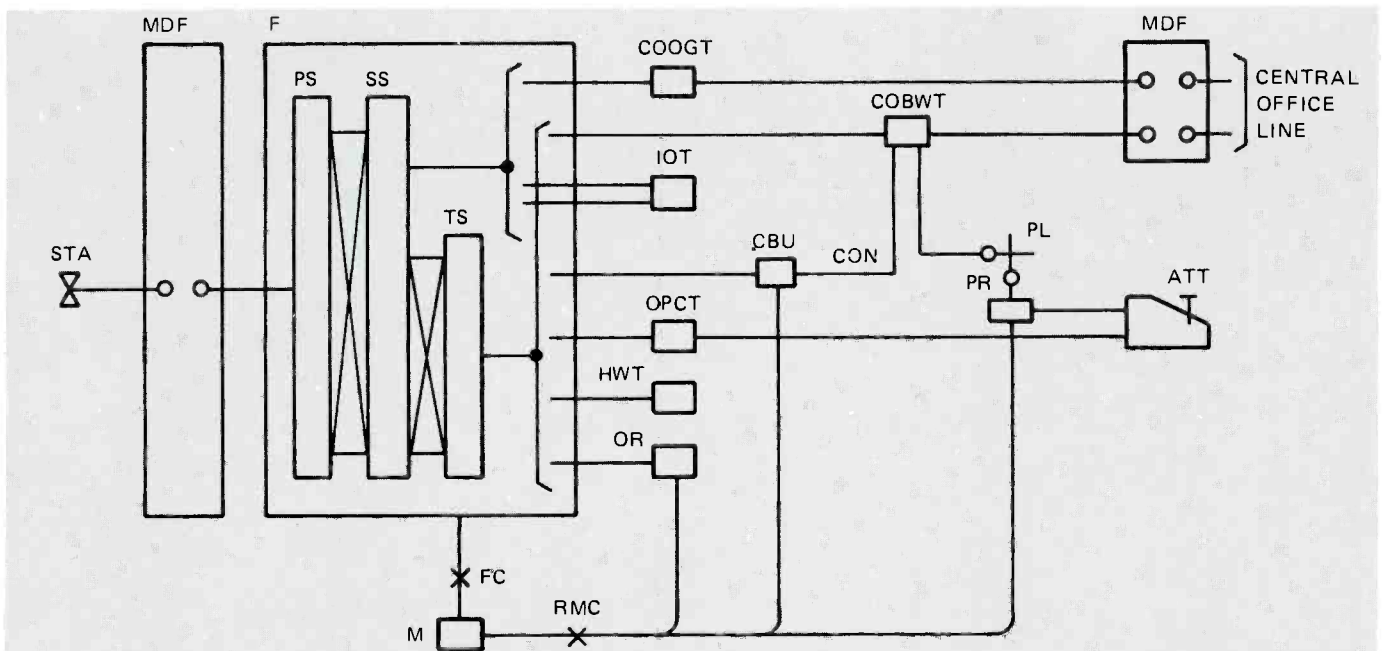
Betulander, who in 1917 designed the coordinated selector using relay-type contact springs. The first American crossbar system was developed by Bell Laboratories and was first used in this country in 1938. It was used to replace the panel system, which was a power-driven sliding-contact system used where high-density switching was needed. Crossbar was subsequently used to replace the step-by-step Stroger type of central office switching machine.

It is interesting to note that it was only within the last few years that the panel systems disappeared. The crossbar and Stroger-type switching devices, using common control and direct control respectively, are still the dominant switching systems in use today. The step-by-step system is used extensively on customers' premises where on-site switching is needed.

If you have other than the twenty-year old telephone sets or the thirty- to forty-year old switching machines connected to that set, you know that your system is quite

new. It will be something less than five years old. Until about four years ago, there was a studied effort to delay as long as possible the application of new technology to customer equipment and to switching machines. Business and marketing strategy dictated a go-slow policy for user-terminal equipment and switching machines. It should be pointed out, however, that this has not been true to the same extent for data modems and data terminals provided by the telephone common carriers.

It is easy to see that new technology application is the only practical approach for the expansion of the transmission facilities. One of the reasons for the recent rapid adoption and, in fact, aggressive pursuit of higher technology in the transmission segments of the telephone companies is that analog and digital transmission equipment is used in other types of communications industries. The space program brought about new demands, military projects and other



TYPICAL TRUNKING DIAGRAM FOR COMMERCIAL SYSTEM

Abbreviation	Nomenclature
STA	Station
F	Frame
M	Marker
FC	Frame Connector
RMC	Register Marker Connector
OR	Originating Register
COOGT	Central Office Outgoing Trunk
COBWT	Central Office Bothway Trunk
IOT	Intra-Office Trunk
OPCT	Operator Call Trunk
HWT	Howler Trunk
PR	Position Register
PL	Position Link
MDF	Main Distributing Frame
ATT	Attendant Turret
PS	Primary Switch
SS	Secondary Switch
TS	Tertiary Switch
CBU	Call Back Unit
CON	Call Back Connector

Fig. 3. The crossbar switch. Major circuit assemblies consist of wire spring relays and crossbar switches and use wired logic for control functions and features. Relays store the dialed information and other "call" information before switching is done.

### Business and marketing

The fourth and last major segment of the telephone industry is the business and marketing component. It is this segment that brings the three other segments (intra-company and intercompany structures, legislative and regulatory, and physical systems) together into a working entity. We will look at that part of the business and marketing activity that has most affected the application of new technology.

We must first recognize that in their historic development the telephone operating companies have been a regulated monopoly. The normal competitive pressures, economic opportunities and user demands have not had the same effect in the telephone industry as in other business environments.

The high operating cost of the early manual switchboards gave way to the high manufacturing costs of the electromechanical switching equipment. With the advent of the step-by-step and panel switching machines came the need for the dial telephone. This technology and its implementation on a system-wide basis was a highly capital-intensive effort.

The physical wire loops between customers and central offices had to meet the technical requirements of the dial pulse configurations, and that made it necessary

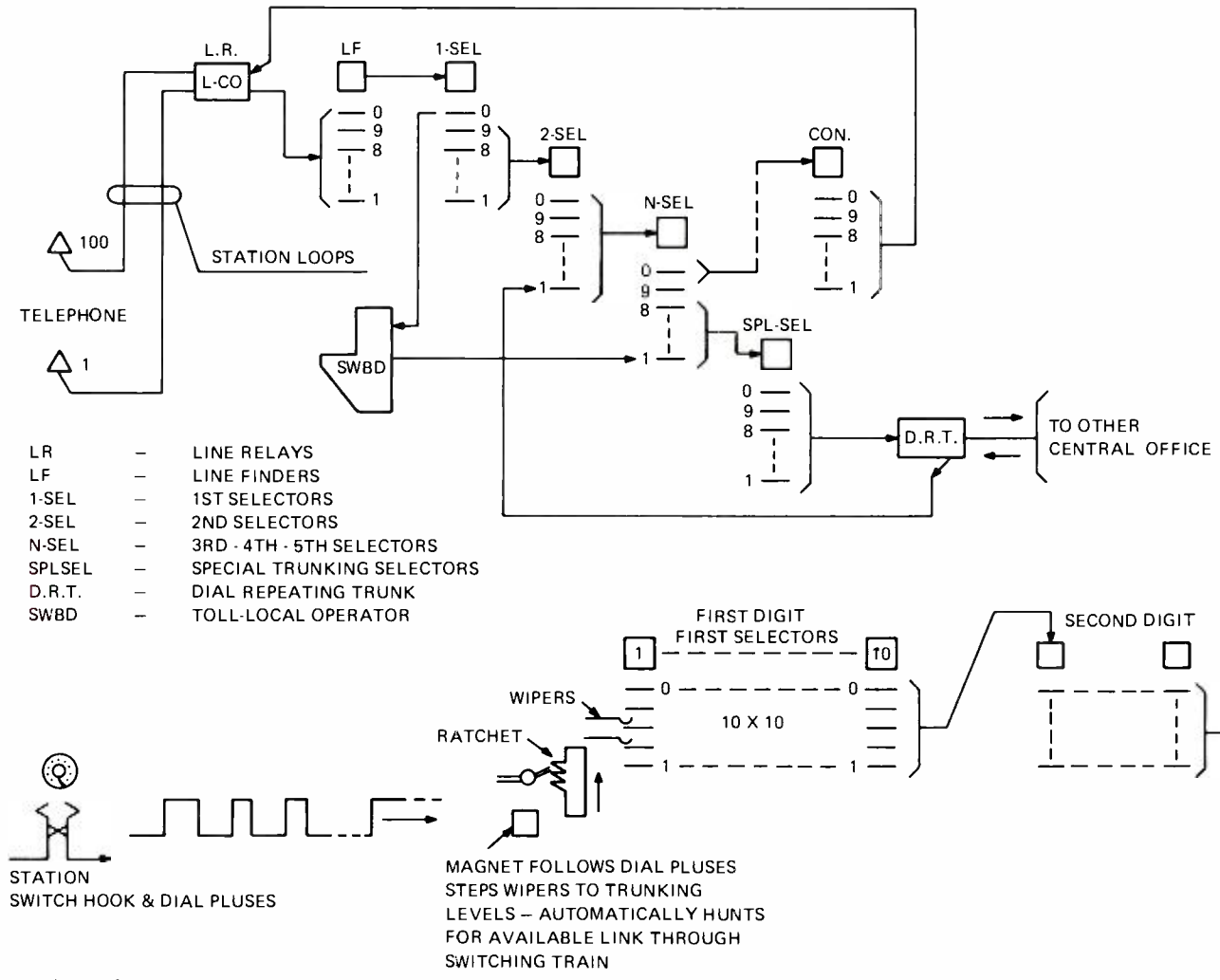
government and industry requirements established expertise, and the development and manufacturing of new technology was an attractive business venture. Many companies not normally associated with a telephone company and otherwise not needing large capital investments were able to develop and market transmission equipment acceptable to the telephone operating companies.

For better or for worse, artificial barriers had been set up by tariffs and regulations to keep the largest telephone equipment manufacturer — Western Electric — from selling equipment in all market areas. It has also been very difficult for manufacturers

not associated with telephone companies to market their products to operating telephone companies that have manufacturing subsidiaries.

These artificial barriers have, in the judgment of many, slowed the rate of implementation of new technology in the largest part of the telephone industry — station terminals and switching equipment. The vertical structure of the dominant companies allowed a coordinated control of the flow of technology between the telephone-company-associated manufacturer and the telephone common carriers. The commissions and tariffs supported, until recently, that process.





**Fig. 4. Direct Control systems consist of many individual switches.** The switching mechanisms of each unit are under direct control of the calling party's dial pulses. The call is processed in a pseudo-random pattern through groups of switches representing each digit.

to pay more attention to the design and maintenance of the cable distribution system.

The investment of capital, manpower and time made it desirable for the operating telephone companies and their associated manufacturers to discourage any rapid changes. There was little pressure on the marketing departments to sell new technology to the customer after the change was made from the manual system to the automatic dial electromechanical system.

There was an almost total conversion from the manual switch boards to the step-by-step electromechanical technology before the common control concept was introduced. This was because there was no marketing pressure to change out switching equipment that had a 25 to 35-year life expectancy. Remember that in the smaller, privately-owned operating telephone companies the change from manual to the electromechanical technology was delayed as long as possible. The operating cost was not as critical an

item in these smaller companies as it was in the larger ones. The cost of installation and the technical skills needed for the application of the new automatic system was a greater problem. Again, there was a strong incentive in the smaller independent telephone companies to market the old technology and discourage the new.

The step-by-step and all-relay systems had some very obvious drawbacks. They required a lot of space, a great deal of expert maintenance, and traffic patterns through the machine needed constant attention. As the cost of operators had been one of the major factors in manual switchboards, the maintenance and space problems became a major factor in the step-by-step and all-relay systems. Figure 4 is a simplified drawing of the step-by-step, direct control system. As we will see later, there are some advantages to the electromechanical technology.

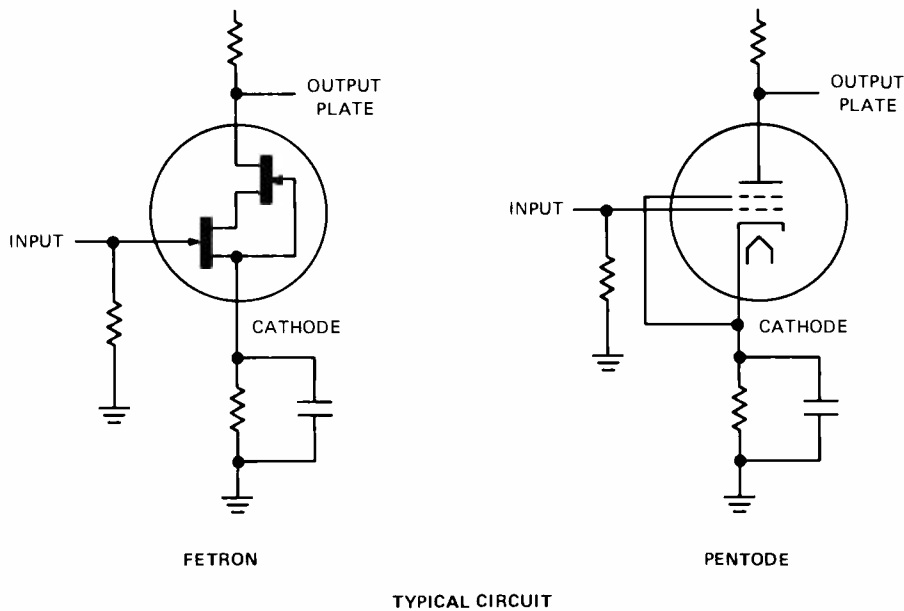
Although there were good business reasons to market "service with a smile" instead of new technology, new technology was being applied to the transmission

facilities in the telephone system in response to changes in customer needs.

The customer calling patterns of long distance traffic changed for several reasons. The suburbanization of our metropolitan areas, the movement of families, the expanded business markets, and an encouragement from the telephone company marketing to make long distance calls were some of the reasons. Electronic tube technology was used in the development of multichannel single side-band carriers for open wire and cable facilities to meet this rapidly growing demand. As transistors became better understood, the tubes were directly replaced with the FETRON device in many systems (Fig. 5).

*Data communications*

As the business user requirements for data communications service began to grow, the opportunity to apply state-of-the-art technology grew. Modern data modems (modulators and demodulators) were



**Fig. 5. The Junction Field Effect Transistor (left) illustrates one approach to the gradual yet efficient application of higher technology in older (right) systems.** Economics dictate that state-of-the-art designs maintain technical and operational compatibility with the telephone network.

designed using new technology. Because the national network was — and still is — for the most part an analog system, the digital interface with the end user's terminal, usually a teleprinter, computer, or processor, must be converted to the appropriate analog signal. The application of new technology and, to a large extent, the development of new technology for the data transmission shows that the telephone industry had the capability to bring the new technology to the end users in a relatively short time.

The fact that the telephone industry had the technical and financial capacity to not only bring the new technology on line, but also to have the potential to dominate the data terminal and computer service market caused additional barriers to be set in place. The regulated common carriers were, and still are to some extent, denied access to the computer and data processing service market.

Had the organizational aspect of the telephone industry been different, there is no question that, at least in the area of the user's interface with the telephone system, things would have been different. We can speculate that if the operating companies such as Southern Bell or General Telephone of Indiana had to look to independent manufacturers for their customer terminal equipment and switching hardware, those manufacturers would have given the operating companies a greater opportunity to market new technology at a faster rate. The rapid use of

satellites is a good example of the industry's ability to not only develop but apply state-of-the-art hardware and software, given the proper incentives. The competitive thrust of legal and regulatory decisions now allow the customer demands to dictate the rate of application of new technologies.

## External pressures

Some fifteen years ago, pressures outside the telephone industry caused the industry to evolve in a way more consistent with available technology. The controls within the telephone industry that, in some areas, delayed the application of new technology were in the process of being removed.

In the data processing field, intracompany communication groups, government and military communication programs, and the so-called right-of-way utilities, such as pipeline and transportation industries, there was a growing cadre of technical expertise at a level equal to the task of changing the telephone industry. Small businesses found that with new technology a great number of things could be done to improve the use of the telephone network. A few businessmen speculated that there was a need for new and different communication services.

If we take another look at the groups of companies that now make up the telephone industry, we see quite a different picture. We not only have the traditional telephone

company structure, but we now have telecommunications operating companies such as MCI, SPC, Tymnet, GTE Telenet, American Satellite Corporation, and of course, RCA's American Communications. These new operating companies sell service directly to end users and are supported by many new large and small manufacturers.

The technology used by these new telecommunications companies is not necessarily new. It is the application of old and new technology in different business and operational concepts. We can now make the transition from the telephone industry to the telecommunications industry. This transition was not possible prior to the Carterfone decision.

Legislative, regulatory and legal conflicts are about as numerous as are new manufacturing and operating companies. Congress and the Senate are struggling to rewrite the Communications Act of 1934, around which the industry has evolved. The stated intent of the proposed legislation is to allow the restructuring of the telecommunication industry. This would also include the data processing industry, allowing it to develop in a manner more consistent with the rest of the business world. Serious issues need to be resolved so as not to allow the dominant carriers such as the Bell and General Systems to capture the market again. State laws and regulatory commission rulings will have to be changed to be consistent with the new federal laws and commission rulings. On March 7, 1980, the FCC announced that it will deregulate all customer premises equipment and allow AT&T and GTE under separate subsidiaries to market data services.

Today, as we look at the structures of the companies, the legislative and regulatory bodies, and the physical systems being installed, we see a very rapidly changing picture. It is fair to say that there is as much, if not more, activity "around" technology developments and application as there is "in" that effort.

## RCA activity

We should not be surprised to see RCA participation in this changing picture. Even prior to the final Carterfone decision, the RCA Service Company was involved in telephone systems design, engineering, installation and maintenance. There are two activities that indicate that RCA, like others in this field, had developed capabilities that were part of the pressures

that brought about the changes in the industry. They are RCA's participation in the missile program and test ranges and our telephone intercommunication business.

The RCA Service Company was developing management and technical skills in the telephone field and in data communication and processing. At about the same time, another RCA Service Company group was marketing and installing internal telephone switching systems for retail stores.

In 1968, when the door to the telephone network was unlocked by the Carterfone decision, the RCA Service Company was ready, willing and able to push it open. The access to the network (through the now disappearing "connecting arrangements") was an opportunity for the RCA Service Company to expand its presence in the telephone equipment terminal business.

You can imagine the many opportunities available to us. After many discussions and studies, it was decided that the course of action best suited to the RCA Service Company at that time was to market our strong suit—*service*. Manufacturers of switching systems for customer premises (private automatic branch exchange—PABX) were knocking on our door. The decision was made that the RCA Service Company was best able to market PABX and Key Telephone Systems (KTS) manufactured by others.

The RCA Service Company is, if not the largest, one of the largest contractors of private telephone terminal equipment in the United States. We have in excess of 500,000 station lines installed, and we can be compared in size to the seventh or eighth largest operating telephone company in the U.S.

The technology used by the Service Company and by others in the new terminal equipment switching systems was the electromechanical crossbar. It is interesting to note that it was the Japanese and—to a lesser extent—European manufacturers who were prepared for this new terminal market. It was not until the change to solid state electronics in switching machines that any significant U.S. manufacturing participation was developed. The operating companies are using some of the Japanese equipment to remain competitive with the terminal equipment companies.

The configurations of the electromechanical crossbar PABX switching machines were unique to the American market (Fig. 3). Although these machines had been designed earlier for the inter-

national market, some changes were necessary to make them compatible with the U.S. network operations and the now infamous "connecting arrangements."

From hindsight, several interesting items become apparent. Had not the foreign manufacturers already been manufacturing an updated crossbar switch that could quickly be modified for the U.S. market, there is some question as to how effectively U.S. companies would have taken advantage of their new access to the network.

Because the electromechanical technology had been around for such a long time there was a large pool of skilled personnel available at all levels to take advantage of the foreign equipment. Training programs for technicians were developed at acceptable costs for the different equipment configurations.

It did not take much time for the marketing groups to get up to speed. In quick order, a large number of new companies were organized (some failed to meet the tests). Terminal equipment companies, specialized common carriers, telephone common carriers, and the associated manufacturers and research activities changed operating and marketing concepts. Federal and state legislative and regulatory action was taken, and in the last ten to twelve years the picture of the telephone/telecommunications industry has been changed a great deal. It has changed at a rate much greater than the technology that fathered it. It will be interesting to watch this process. It may not change the technology, but it will certainly effect its application.

## New standards

Those of us who are directly involved in the implementation of new systems are aware that standards for these new telecommunication systems, both voice and data, are still in the development stages. This is particularly true for telephony. True data message control, software protocol, and system "hand shaking" are still not fully standardized and may not be in the foreseeable future, but in the field of telephony there are special problems.

This becomes obvious when we consider the telephone industry, in its somewhat closed society, developed its own terminology and standards. What is not so obvious is that there are standards for the Bell System, and different standards for, say, the General Telephone System. As long as each group furnished its own

equipments there was little reason to integrate the different standards. The only place the systems come together is at the toll connection—not a significant problem.

On investigation, we now find that the rapid changes have created "standards" problems. To the systems engineer this is not surprising. New applications create many unforeseen problems. Integrating new technologies into a system that was designed more than thirty years ago can and does create standards problems. What is gratifying though is that although "industry" standards are just now being developed (EIA Standards for PABX have been approved), integration with the existing systems is not an overwhelming problem. However, care and attention are needed where new products interface with the network and terminal systems. There are few cases where incompatibilities require a major redesign effort. Again, thanks to expertise within the industry, problems—when encountered—are resolved quickly and at acceptable cost. A possible exception to this is the difference between the 32-channel European and the 24-channel North American pulse-code modulation (PCM) digital formats.

The most common interface problem with the network is the supervision signal timing. These are the signals that indicate the connect and disconnect sequence, reconnect, and start and stop dialing signals. With the crossbar systems, relays are operated and released within fairly liberal limits. However, when the crossbar equipment is connected to step-by-step or electronic systems, the timing must be considered in detail. Manufacturers who recognize these timing problems provide either software or hardware flexibility so that the installer can adjust timing intervals when connecting to other systems or the network.

## New technology application

Until the last few years, the use of high technology in end-user telephone terminal devices, PABX and KTS design has been retarded. With the advent of competition for the end user market, we have seen some very innovative thinking. We will look at two specific areas: the PABX and KTS systems.

The concept of space division that was used in electromechanical PABX and KTS hardware was used to a great extent in the first electronically controlled systems. SCRs were used for either single "wire"

unbalanced or two "wire" balanced switching. The common control at first was a wired program with almost no flexibility in features or functions. This quickly gave way to flexible programming using either PROM or diode pin matrix. With the use of RAM memory, software began to take on a greater importance. Within the past four years we have evolved through the various levels of space division, time division multiplexing (TDM), analog and delta modulation, and pulse code modulation (PCM).

It should be noted that in switching machines there are several optional configurations that can be applied. The analog or digital transmission concepts can both be used in any given design. The analog may be more economical in one part of the switching process and the digital in another part. The options for space division and time division may also be mixed in any one machine.

The rate of change in the cost of TTL and CMOS technology has, of course, had its impact during the past few years on the choice of the transmission and switching concepts. The associated software for both system operation and the customer data base is also influenced by the cost and flexibility of memory hardware. There are mixtures of solid state RAM and ROM units and magnetic tape program storage.

Today, the 8080-type LSI chip is in wide use. Distributed-control multiprocessors with full redundant capabilities are being used. Systems are now designed using A/D and D/A converters, PAM, PCM, and real-time store and forward switching (Time-Space-Time levels) all in the same machine. These applications were only dreams to telephone engineers just ten years ago.

The latest state-of-the-art technology is now being implemented in PABX and the Key Systems. This trend is true in almost every aspect of telephone terminal equipment. The use of bubble technology may, in the near future, add another factor in the choices of the transmission and switching concepts, and the central processor unit (CPU) may be used in switching systems as it is in other terminal systems.

The telephone/telecommunication "industry" is in the process of making drastic changes so that it can take advantage of the very rapidly changing technology. What impact new developments such as the super-fast, super-conducting Josephson junction device will have is left to our imagination and the structure of the industry.

The options now available in the PABX

and KTS systems are almost unlimited. Many of these "on customer premises" systems have RS232-type ports for interfacing with ancillary systems. Again, the list of "add-on" systems is long. To name a few: hotel/motel management information systems such as on-site reservation, guest call detail record or station message detail recording (SMDR), room and maid status, and energy management. Industrial/commercial systems can have the SMDR system, least cost routing, conferencing of several parties through dial access, four-wire data line switching, and remote access to special private lines.

The telephone set itself is becoming a data processor. Speed calling or abbreviated dialing, single button access to features, programmable call forwarding, voice calling (paging), and cramp-on or ring-again for lines found busy are all now in wide use. Some telephone set designs look more like data terminals than telephones. The terminology of the telephone terminal is changing also. The differences between Private Branch Exchange and Key Telephone System have blurred. We now have what is called a multi-function terminal. It is both PABX and KTS. Is it any wonder then that the FCC, in its announcement on the Second Computer Inquiry, stated that all terminal equipment should be deregulated?

## Systems considerations

Until recently the terms software, memory, and processor control were not common in the telephone industry. Although sophisticated solid state (LSI) hardware was used in the transmission facilities such as the T-1 carrier, radio (microwave) links, and data terminals, high technology has only recently been used for telephone terminal systems. This late and rapid application of this higher technology to these systems has not been without its problems. The marriage of computer technology to the telephone terminal equipment has been a "shotgun" affair. Computer and data processing engineers have had a difficult time transferring their expertise to the telephone terminal environment. This is true also for telephone systems engineers. They have not fully appreciated the environmental differences between the old and new technologies.

It is important in this presentation to alert those engineers who have experience in the higher technologies that these environmental problems have not been

fully resolved in the telephone terminal marketplace. At the top of the list is reliability. The telephone terminal equipment has, in the past, been a wonder of reliability. The solid state technology has a long way to go in reliability assurance in the telephone terminal environment. The crossbar switch, the telephone sets, and the multiline key system and its associated wiring are so reliable that a failure is rare. Spare parts, are, with few exceptions, not on hand and, in most cases, are ordered from the manufacturer or distributor when a failure is experienced.

Spare parts for electronic telephone terminal equipment are a cost factor far in excess of anything experienced for older terminal equipment. Spare parts can be as much as 30 percent of the system cost. Managing and storing these spare parts, mostly printed circuit boards (PCB) and program tapes, is an activity and cost new to the terminal market. There are several reasons for the high failure rate of PCBs, and that brings us to the next item.

Unlike the data processor computer, telephone terminal equipment is exposed to a wide range of electrical hazards. Telephone lines are subjected to high voltage contact, lightning, and voltage fluctuations. The treatment of telephone lines for the electromechanical and non-LSI technology is significantly less than for the higher technology. Protection from these hazards is just now being developed and applied. This is a cost item not originally figured into the cost of the new technology.

The AC main power noise was not a problem with the older hardware. The new systems must be located away from electromagnetic noise and isolated from AC power noise and surges. The terminal equipment using CMOS technology is, through the connecting wiring, subject to a high incidence of electrostatic shock. Extra effort is needed to protect this equipment from the antenna effect of the wiring between the PABX or KTS and the station instrument. Once telephone personnel are made aware of this problem it can be reduced or eliminated, but at a cost not normally associated with telephone equipment.

The third item is power. The electromechanical technology uses AC power in a very efficient manner. When a step-by-step or common control crossbar system is not in the process of switching, it consumes almost no power. Power usage for a typical 100-line crossbar system is around 8 amps, or about 400 watts assuming 4 hundred Call Seconds (CCS) per line during the



**John Bakas** is Manager, Technical Planning and Support, Telephone Systems Support. He joined RCA Government Services in 1959 as a telephone systems engineer. After assignments to several test range projects and the Air Force's Datacom project, he joined Consumer Services, Telephone Systems, in 1971. He has wide experience in telephone transmission, traffic, and switching systems engineering. His present responsibilities are assisting in evaluation of products for use in Telephone Systems' Interconnect business and helping with the resolution of problems with the operating telephone companies.

Contact him at:  
**RCA Service Company**  
**Cherry Hill, N.J.**  
**TACNET: 222-5423**

busy hour (0.11 Erlangs). A typical electronic PABX in the 100 line size consumes about 1200 watts no matter what the traffic is, and it draws that power continually. This high power consumption costs the customer much more than the older systems did.

The fourth item is related to skill level, maintenance effort and software support. The telephone technician has, in the past, been able to repair a failure on site with little or no spare equipment or support. The LSI and PCB technology requires that the repair man have an extensive understanding of the hardware and software or the system must be equipped with high-cost self diagnostics with indicators or reference codes.

Further, the rapidly changing designs in hardware and software make training an

expensive item, both in expense and in man hours off the job. A technician cannot repair a PCB on site and, in most cases, the faulty PCB must be returned to the manufacturer or depot. A spare PCB must be available. The higher failure rate (MTBF) of solid state systems, the cost of PCB repairs, the greater length of time to locate the failure (MTTR), the cost of diagnostics, and the added training levels are costs not found in the older technology. An added cost factor of the MTTR is that in many systems the maintenance or even the testing for a defective PCB or power supply cannot be done without taking the system out of service. This effort would be done at night and at premium time labor costs. The higher levels of internal system diagnostics will help reduce MTTR and its associated costs.

Associated with the hardware failures are software bugs. The manufacturer must continue to provide support for its systems. That coordination takes time and costs may be incurred by customers when the system is not fully operational. This level of manufacturer support is not necessary with the older electromechanical systems.

The fifth item is the added cost of air conditioning. This is another cost factor not normally considered in the original cost of the equipment. Although air conditioning and other environmental controls are well understood and accepted for computers, it has not been so for telephone terminal systems. Special considerations are now necessary when installing the telephone PABX or KTS. The capital investment in an air conditioning system and its operating cost now become a new factor for telephone terminal installations. The environmental controls must be operational 24 hours a day, every day.

The welcome infusion of higher technology into the telephone terminal world has not been without its challenges.

These challenges are, in fact, growing. The telephone industry is not what it used to be. There are specialized carriers among the historical operating telephone companies. The legislative and regulatory

activities tell us that more significant changes are coming. Business and Marketing concepts have changed the organizational structure within the telephone companies. A quick look at terminal systems that are now available tells us that telephone and data communication are almost one and the same things. We have come a long way just in implementing the existing modern technology. We can only guess what the future holds.

## Conclusion

What has the telephone industry learned in the last ten years? One thing is sure—technology itself is a major influence on the regulatory, legislative and business evolution that is restructuring the telephone industry. This process will continue and we should expect it to proceed at an even faster rate.

What can we expect in the next ten years? More of the same? A good guess would be no, not the same. We have seen drastic changes "inside" the telephone industry. What we should expect and, in fact, should work toward is the integration of telephony and data processing into one system. Word/data processing equipment and services would become the "terminals" in the telecommunications system. These terminals would have analog and digital capabilities. (Analog may disappear in the 90s.) The communications links for these new terminals are now becoming viable. Systems being planned now are anticipating that terminal systems and services will evolve with the communications network.

As technology is developed in any segment of the industry, it will quickly find its way throughout the telecommunications industry. It is incumbent upon the telephone systems engineers to develop a working knowledge in both disciplines. The real challenge is still ahead of us. Take a good look at that telephone on your desk. It may be a collectible in the not too distant future.

# CISS means worldwide communications

*Efficient, up-to-date corporate communications are an absolutely essential ingredient of successful business. Corporate Information Systems and Services is charged with finding innovative ways of meeting those demands.*

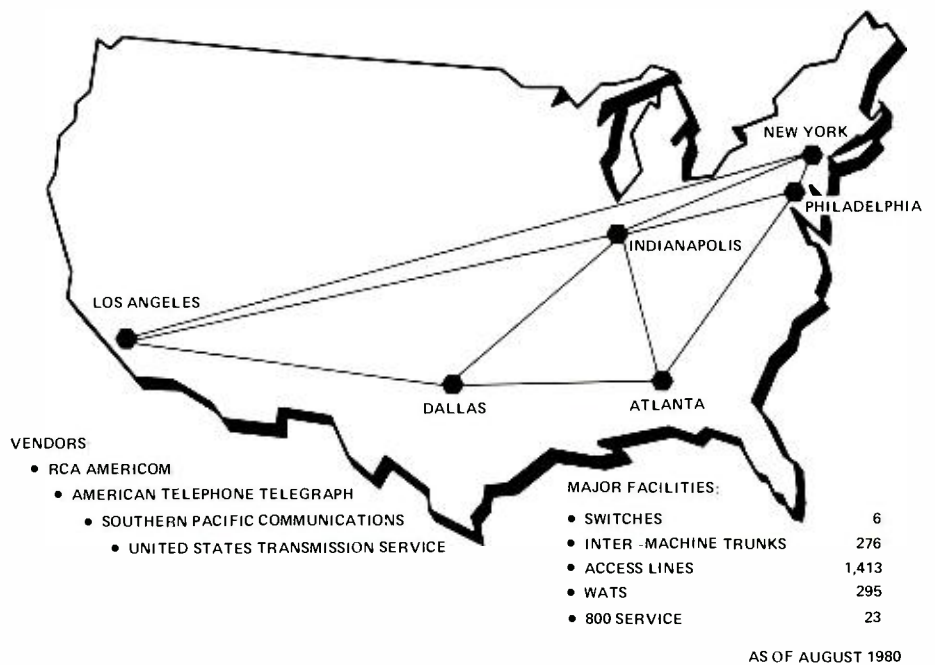
**Abstract:** *The author gives descriptive data on RCA's TACNET Voice/Data Network, the International Data Network and the Shared User Teletype Network.*

Corporate Information Systems and Services, or CISS, provides all of the major operating units of RCA with voice, data and teletype facilities. Efficient management of resources keeps the cost of these services at a minimum. Particular emphasis has been given to establishing three unique but integrated services — TACNET (Voice/Data Network), IDN (International Data Network) and SUN (Shared User Teletype Network).

## TACNET

The impetus for the development of TACNET was the realization that the Corporate Telecommunications Network (CTN) had become technically obsolete. Customer concern about unreliable data/voice transmissions, non-uniform dialing complexities and the absence of traffic information dictated the need for a more effective state-of-the-art shared network to support growing customer needs.

Our evaluation of available alternative systems determined that the AT&T Enhanced Private Switched Communications Service (EPSCS) afforded the high levels of service that we felt met the



**Fig. 1. Electronic switchers located in the cities shown are interconnected to form the backbone of the TACNET network.**

needs of RCA. Today, EPSCS provides the switching for the RCA telecommunications system known as TACNET.

This domestic network provides point-to-point, 4-wire equivalent, user-dialed private line switched service for voice and data transmission of up to 4800 BPS. This includes facsimile transmission to all appropriately equipped locations. Service is provided to virtually all domestic RCA and subsidiary locations that generate significant amounts of long-distance traffic. These locations also enjoy service to any listed telephone in the continental United States, Alaska, Puerto Rico and the Virgin Islands via off-network facilities.

TACNET is based on an integrated network of four major long haul carriers: RCA American Communications, Inc., American Telephone and Telegraph Company, Southern Pacific Communications and United States Transmission Service. As shown in Fig. 1, electronic switches located on telephone company premises in Atlanta, Dallas, Indianapolis, Los Angeles, New York and Philadelphia are interconnected to a total of 284 Inter-Machine Trunks (IMTs), 317 Wide Area Telecommunications Service (WATS) lines and 1400 access lines connecting TACNET locations to the switchers. The network comprises over 380,000 circuit

miles. At the present time, over 37,000 telephones that generate some 1.5 million calls per month are being serviced, with over 120 locations directly connected.

The core of TACNET is its computerized routing of outbound access. Dedicated portions of the six AT&T switches control voice/data traffic flow over IMTs that connect on/off-net access lines and switches. On-net activities use private line point-to-point circuitry, while off-net interests are served by WATS, Local Off-Net Access Line Service (LONALS) and Foreign Exchange Service (FX). Figure 2 illustrates these interrelationships.

On-net use (calls between RCA locations) involves tailoring options to meet local customer needs. Typically, ingress is gained by dialing a 1-digit TACNET access code, the 3-digit exchange, the 4-digit extension and a 5-digit authorization code. The user authorization code ensures legitimate usage and accurate cost allocation.

Off-net service requests (from TACNET locations to non-network locations) are dialed the same way as on-net requests, except that the customer must add the area code of the number being called. A special feature, remote on-net access, is designed for authorized traveling users who must call from non-network to TACNET locations. This is done through local and inward WATS facilities. The call is then forwarded over the network by an RCA attendant or self-dialed to the desired number.

Regardless of the calling sequence used, it is the behind-the-scenes activity involved for each access that reflects the special utility of the TACNET concept. Through its computerized switches, the collection of significant call detail information is made possible. Specifically, signal processors located at each switch, form part of a data network that communicates call record data to the CISS Customer Network Control Center (CNCC) located in Cherry Hill, New Jersey. CNCC uses this data for network engineering, status monitoring, problem resolution and for billing purposes. Identical data is transmitted to AT&T's Chicago Customer Service Administration Control Center (CSACC) to ensure maintenance backup and expedited vendor responsiveness.

Network engineering depends on call record data to determine each location's requirements for the number of circuits, service levels, etc. Customer needs are tailored through constant analysis of user calling patterns to effect improved benefits

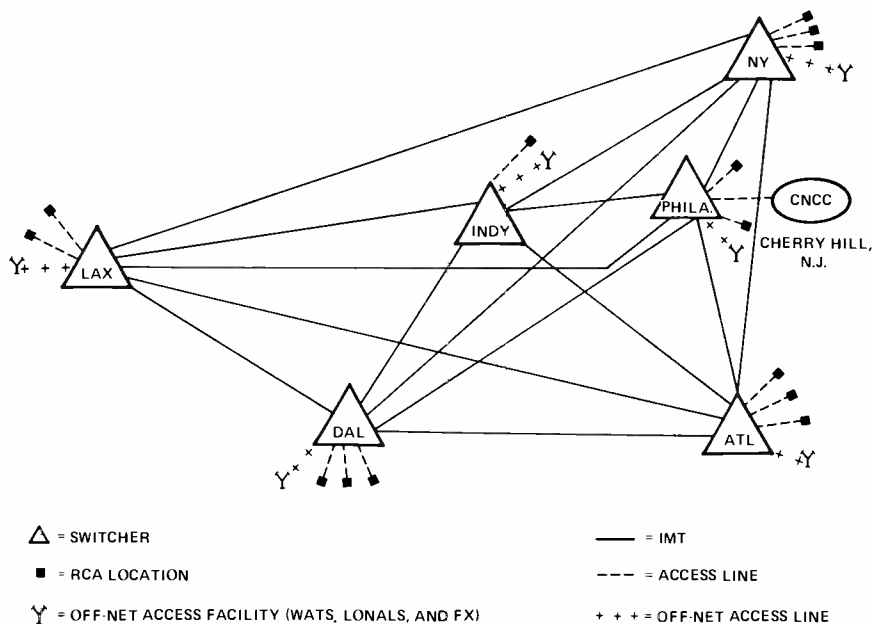


Fig. 2. The interrelationships of the major TACNET components are graphically depicted above.

that will be consistent with TACNET facilities cost. Additionally, network engineering, recognizing that vendor charges vary depending on the offering used, has developed an economic route selection algorithm for off-net calls. This algorithm is stored in each switch to control the dispatching of calls in a manner that takes advantage of changing costs for the time of day and distance involved. This feature is transparent to customers who simply dial the desired number. It is up to TACNET to provide required connections, and customers are not charged more if calls overflow to more expensive services.

The value of call detail data is equally evident in its daily use by the CISS Customer Network Control Center. Here network feedback and customer trouble reports are collated at a central point. This permits a near real-time service level observation and status review of TACNET's operation to make certain of timely remedial maintenance by vendors.

From a customer perspective, perhaps the most significant advantage of call record data is its contribution to equitable cost distribution. Specific information is available about each call attempt indicating resources consumed, thus providing the basis for a usage-sensitive billing system.

The advantages of TACNET performance are illustrated in Fig. 3. The dotted line represents usage in terms of minutes of conversation. Network costs are shown by the solid line. It is interesting to note that since cutover in mid 1978, the trends indicate an increasing call volume with decreasing costs. The ultimate success of any new system depends on customer satisfaction. The evidence so far continues

to support the wisdom of the TACNET decision as the means to deliver to customers an efficient, reliable and cost-effective alternative to traditional voice/data service.

## International Data Network (IDN)

The CISS charter to provide RCA business units with rapid, reliable, low-cost data transmission includes international as well as domestic services. To meet this need the International Data Network (IDN) was developed to extend computer access to customers located in Europe and the Far East. Designed initially to support the global requirements of the Solid State Division in Somerville, New Jersey (*RCA Engineer*, Vol. 25, No. 5, Feb./Mar. 1980), the IDN concept has attracted other RCA users. A list of some of their applications is shown in Fig. 4.

Geographically dispersed customers gain access to the IDN through nodes in Brussels, Belgium and Sunbury-on-Thames, England. Through these nodes, the customer is connected to either of two computer sites located in Cherry Hill or Somerville, New Jersey (Fig. 5). A single 9600-BPS trunk line connects Brussels with Sunbury, while dual trunks connect Somerville and Cherry Hill. A single 9600-BPS transatlantic cable connects Somerville with Brussels, and dual 9600-BPS transatlantic cables connect Cherry Hill with Sunbury. These loops allow for alternate routing in case of a lost circuit. Malaysia and the Republic of China are linked directly to Somerville via 4800-BPS satellite circuits.

### TRAFFIC VS. NETWORK COST

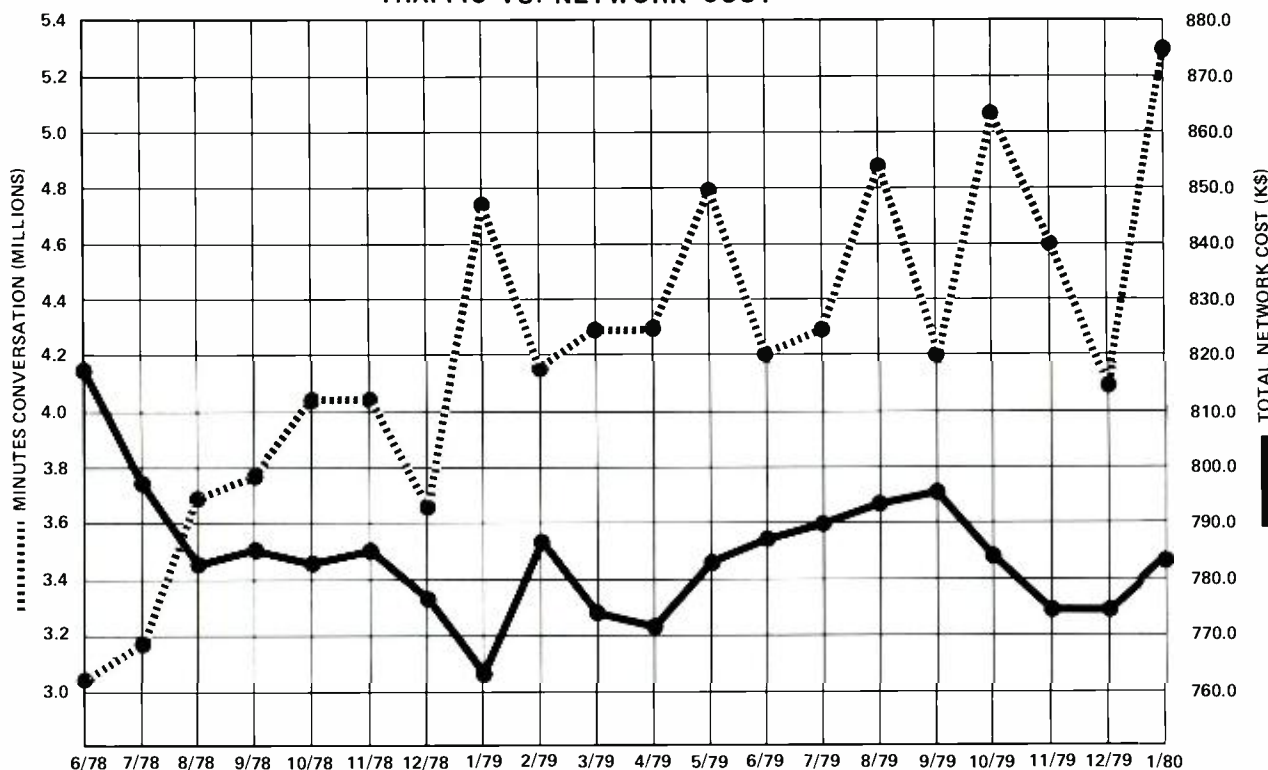


Fig. 3. A plot of the cost-effectiveness of TACNET through the end of 1979 shows increasing use while cost has been controlled. This has resulted in an ever-decreasing cost/unit of time.

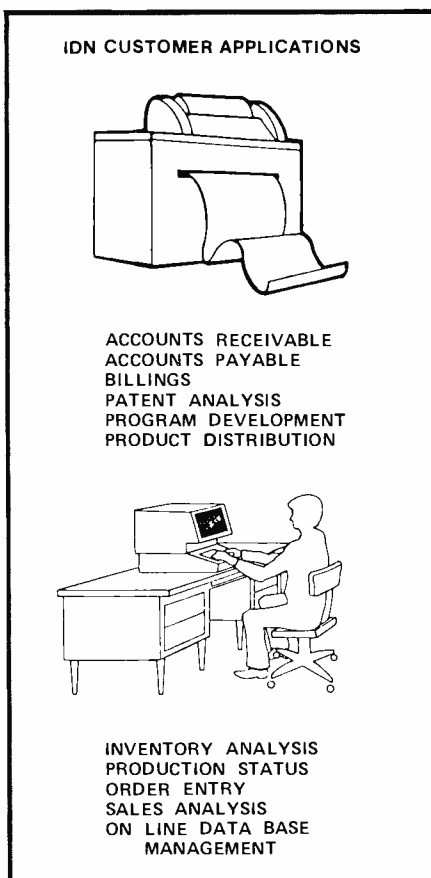


Fig. 4. Typical applications accessed through IDN are illustrated. This list continues to grow.

For traffic control, a medium-scale Comten 3670 in Somerville and larger dual Comten 3690s in Cherry Hill serve as front-end processors that interface the network to the local IBM data processing system. Comtens located in Sunbury and Brussels act as concentrators. Transmission may be received from Remote Job Entry stations (RJE), terminals accessing the Customer Information Control System (CICS), Time Sharing Option of Multiple Virtual Systems Operating System (TSO), or the Conversational Monitoring System of Virtual Memory Operating System (CMS). The Comtens route traffic to the appropriate computer and back to the customer's station.

Traffic volume is distributed between the two transatlantic trunks in order to provide maximum throughput between the United States and Europe. Predetermined traffic routes programmed in the resident software of the Comtens are responsible for this routing. A major feature of the IDN is its ability to use a software feature called Site Initiated Line Switching (SILS), which allows operators to dynamically alter predetermined traffic paths. This control is necessary in the event of a circuit malfunction along the original route. In addition, one of the two trunks between Sunbury and Cherry Hill is switched to voice traffic from 8:00 a.m. to 6:00 p.m.

Eastern Standard Time and to data traffic the remaining weekday hours.

Another major application of the IDN is the Shared Users Network (SUN). SUN uses the trunk between Cherry Hill and Sunbury to funnel teletype traffic from 18 dedicated circuits worldwide to its control center in the United Kingdom.

The Comten computers use a network software package called CNS that combines the binary synchronous traffic of the RJE, TSO and CICS applications with the low-speed asynchronous start-stop traffic of SUN and interactive time sharing. The remote COMTEN concentrator employs a technique known as adaptive multiplexing to transmit data through the connecting trunk. The destination COMTEN separates the various types of traffic and routes it to the appropriate terminals or host computers. This feature, combined with the traffic reroute capabilities, makes the IDN a flexible tool for CISS. In turn, CISS extends these services worldwide to RCA users.

Full control of all nodes from Cherry Hill, combined with diagnostics capable of tracing routes provides the troubleshooting aids necessary to maintain the integrity of the network. The reliability and flexibility of IDN help make it cost-efficient. In addition, concentrators on the



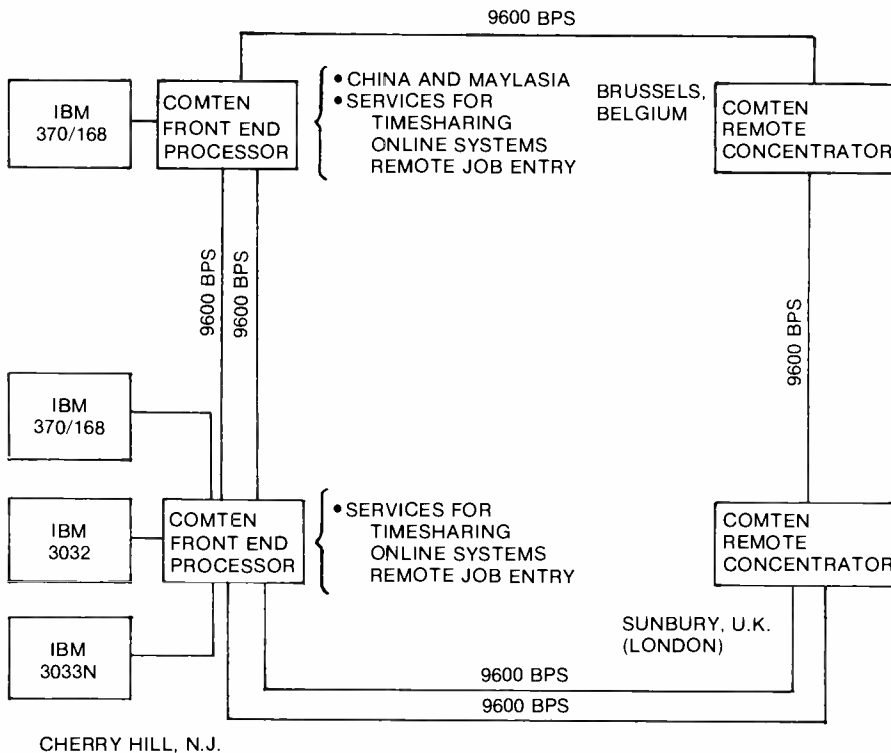


Fig. 5. Geographically dispersed customers can gain access to the IDN through the COMTEN nodes. In the event of line failure, alternate paths are automatically selected.

end points mean substantial savings because of the reduced need for telecommunications facilities. The International Data Network provides the RCA community with state-of-the-art teleprocessing at minimal cost.

### Shared Users Network (SUN)

The RCA Shared Users Network (SUN) is a computer-controlled switching system servicing a private-line teletype network. This network interconnects RCA locations in the United States, South America, the Far East and Europe. SUN comprises two subdivisions: SUN America, serving the western hemisphere and the Far East; and SUN Europe, serving Europe (Fig. 6). The operation of the system is controlled by two General Automation SPC 16/65 mini-processors. Both computers are located at RCA Limited, Sunbury-on-Thames, Middlesex, England. Centralization of the processors, which are umbilically linked, has proved to be operationally and economically advantageous.

SUN uses the trunks of the International Data Network between Cherry Hill and Sunbury for transmitting teletype traffic. Approximately 18 dedicated circuits are funneled into the Comten 3690 in Cherry Hill, concentrated with other asynchronous and bisynchronous signals,

and transmitted across the trunks to Sunbury. In Sunbury, a Comten 3650 intercepts the data, disbands it, and forwards the teletype data on to the SPC 16s and the other data to their appropriate destinations.

Some of the features provided by the computers are variable sequential polling, store and forward, group and broadcast distribution and message retrieval. All messages transmitted are prepared in advance on perforated tape using local teletypewriter equipment (transmitter distributor). As a message is typed, a tape is cut simultaneously on the same terminal. Stations may be equipped with either 8-level 150-baud terminals for cutting tapes, or 5-level 75-baud terminals. The 8-level terminals are connected to lines capable of transmitting approximately 136 words-per-minute. The 5-level terminals are connected to 100 word-per-minute lines.

*Store and Forward:* When preparation is complete, the tape is readied at the transmitter distributor (TD). After the message is loaded it waits for the processor to take roll call. Sequential polling is done on a continual basis for each network station control unit. The unit receives a signal and relays a ready response back to the processor. An invitation to transmit is returned to the sender and the message is forwarded. The computer then checks for format errors and

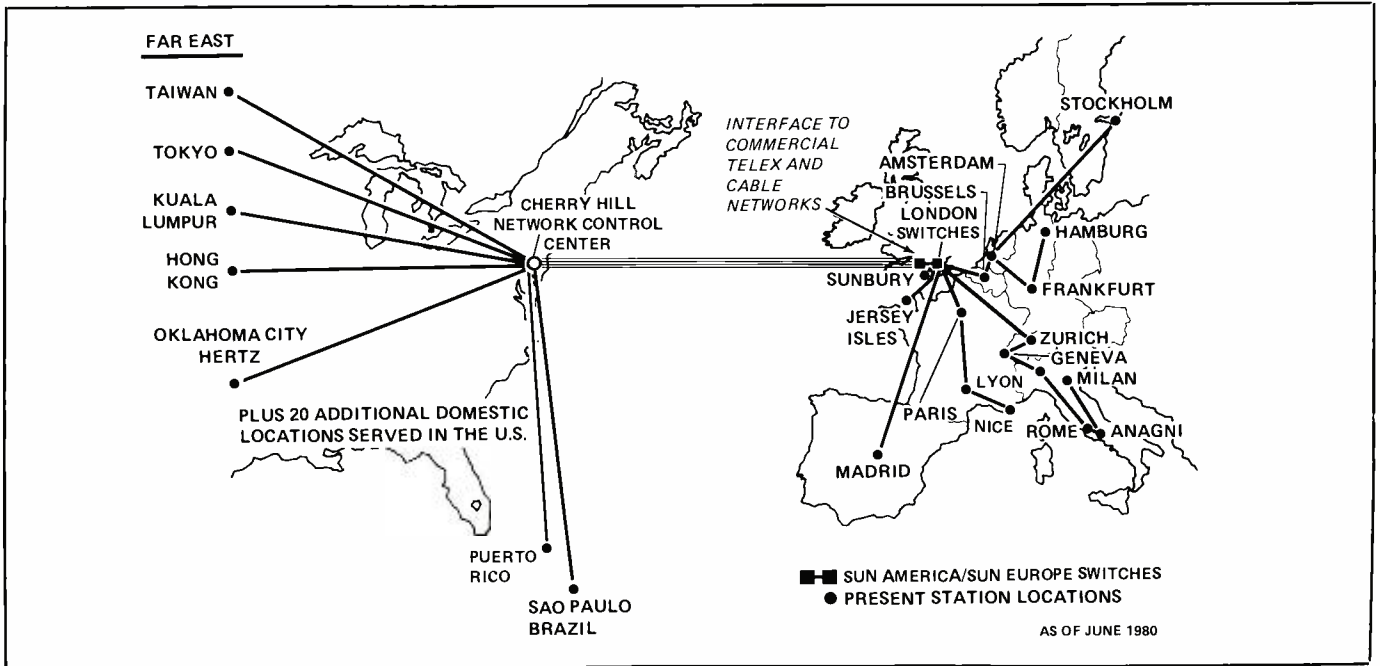
stores the message in queue(s) for each addressee. In real-time, the computer selects the destination station(s) by transmission of a code. A signal is then relayed back to processor informing the computer that the addressee is available for reception. The message is forwarded and transmission completed.

Store and forward greatly improves transmission facility efficiency and smooths out traffic peaks. A stored message is converted to the speed and format of the receiving station, allowing greater flexibility within the network. SUN handles three basic types of messages: those with a single address; those with two or more addresses; and those with group addresses. This last type of message is designed to meet the recurring requirement for the dissemination of information or instructions to fixed groups of addresses. One message may be sent to as many as 16 addresses with a single transmission.

Through the use of broadcast commands the network control center has the ability to reach all stations, domestic and international, on a priority basis. With a single transmission the control center can advise customers of the system's status and any abnormal situations such as power failures, natural disasters, malfunctioning stations, etc.

If a message is garbled or incomplete, it may be retransmitted if the receiving station issues a retrieval request. The retrieval request consists of a sequence of identification numbers (if legible), a range of numbers in which the message was to appear, or simply the time the output was to be received. In the event the retrieved message remains illegible, a service message may be sent to the station of origin, requesting the message be retransmitted. The retrieval process may be done on line at any time. However, for a message over 24 hours old, manual intervention (disc demounting and mounting by control center personnel) is required. A maximum of 30 messages may be retransmitted by a single request.

The versatile SUN offers an automatic refile package, known as SUNATS, which affords automatic interface with the international Telex network. With SUNATS, a customer has access to and from non-network addresses in Europe, Africa and Asia (Telex stations) as well as international cable service without any manual refile being performed by the control center. In addition, if a customer desires to send a TWX or Telex message domestically or internationally, SUN provides a manual



**Fig. 6. The SUN teletype network interconnection to worldwide stations keeps messages flowing.**

refile service that is transparent to the sender.

SUN offers teletype service on a 24-hour, 7-day-a-week basis. Lines are readily available to handle RCA corporate worldwide administrative traffic. SUN provides RCA with efficient, cost-effective worldwide record communications.

## Conclusion

In the function of RCA's corporate telecommunications utility, CISS has the challenge of providing the systems and services necessary to satisfy the diverse, worldwide needs of the RCA Corporation. As these requirements evolve CISS will continue to deliver innovative, cost-effective offerings to meet the challenges.

**Forrest Smoker** is Director, Network Services in the Corporate Information Systems and Services organization. He is responsible for the continuous optimization of the RCA telecommunications network called TACNET. He has a small staff of traffic engineers/computer specialists who rely heavily on the Corporate computer center to analyze network performance and make adjustments. Mr. Smoker has handled many assignments in the data processing and telecommunications fields since joining RCA in 1959.

Contact him at:  
**Corporate Information Systems and Services**  
**Cherry Hill, N.J.**  
**TACNET: 222-6633**



# Teleconferencing is a telecommunications alternative to travel

*Stop, look, listen! Here's a business that will emerge sometime during the 1980s.*

---

**Abstract:** *The author reviews the basics of teleconferencing, presents some of the obstacles, gives the latest techniques and then recommends split-scene techniques.*

---

The telephone has become an accepted and indispensable tool of business. As a means of communication it has, to a large extent, replaced the written word. But the telephone set, *per se*, has not entirely replaced the need for face-to-face meetings. In pursuit of this intimate contact, business executives, engineers, marketing personnel and others each year travel many millions of air miles and spend thousands of nights in motels. Quite apart from the expense of the travel there is a serious loss of manhours while the travelers are between destinations. In addition, the continual travel causes a severe mental and physical strain. The conduct of business among geographically dispersed organizations is severely hindered by the inconvenience, strain and cost of travel. Issues needing rapid resolution are delayed until the next regularly-scheduled visit or are tabled and batched together until a visit can be justified.

Teleconferencing, holding a conference with telecommunications rather than face-to-face, has been considered and implemented by many groups in the last fifteen years. Teleconferencing presents a viable alternative to face-to-face contact. With proper system design, it should be possible to provide a facility that would

enable a meeting with remote participants to proceed virtually as if all the attendees were in the same conference room. With the availability of such a facility, long-distance meetings (for example, engineering working sessions) could be held on short notice. Since the need for travel days and airline and motel reservations would be eliminated, meetings could be held when they are required, rather than when they can be arranged in accordance with restrictive travel constraints. Busy executives could hold review meetings with subordinates at diversified geographical locations on a single day by simply walking down the hall to the conference room. Teleconferencing would allow issues to be addressed as they arise; the incentive to postpone meetings until the next visit would be removed. Therefore, conferencing systems can be expected not only to supplant travel expenditures but also to generate new revenues as well. Increased productivity and rapid access to resource people are significant benefits.

A number of companies have previously experimented with teleconferencing systems. Such systems are currently available between major cities in the United States, Great Britain, Canada, Australia and Japan. In the past, however, cost and technical limitations have presented a practical hurdle to the success of a teleconferencing system. The advent of satellite communications, the emergence of inexpensive electronic devices and increasing energy travel costs add a new dimension to the viability of such a system. In addition, marketing studies estimate that potentially half of all U.S. business

travel is replaceable by teleconferencing with an immediate revenue potential of 3- to 5-billion dollars. These estimates are predicated on a "cost/effective system offering."

In light of increasing energy costs, stabilized costs for communications hardware and transmission facilities and increasing costs of wasting professional manpower, teleconferencing is a business that will emerge sometime during the 1980s. While the revenue potential is large, substantial hurdles must be overcome. The challenges for a communication service company wanting to tap this potential marketplace are: to understand user requirements and human engineering, to reduce transmission-bandwidth requirements and to reduce terminal transmission equipment costs.

## Basics of successful teleconferencing

Teleconferencing systems always include audio connections between separate groups. Enhancements to the audio components range from graphics capability — such as facsimile or slow-scan TV — to full two-way video transmission. The identified systems range from fairly simple two-studio audio systems, to very large or sophisticated networks.

The fundamental reason for the trend toward complexity is the need to fulfill the "human factors" aspects of teleconferencing. Successful conference systems give the conferees as many degrees of freedom as would ordinarily accrue in face-to-face

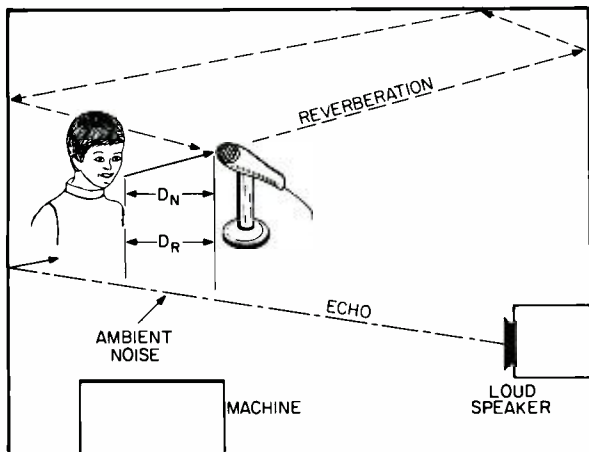


Fig. 1. Audio system disturbances.

contact. The options include the ability to view all the remote participants, observe facial expressions with good definition and view graphical materials and presenters simultaneously. It would seem then that teleconferencing would eventually gravitate toward wideband visual systems. Were it not for transmission and studio cost factors, this would undoubtedly be true.

This paper describes some experimental audio/visual systems implemented at the Laboratories.\* The emphasis is on design and signal processing techniques aimed at providing acceptability, minimizing terminal costs and maximizing transmission-channel use.

## Starting with good audio

The audio section of a teleconference system consists of terminal equipment with microphones and speakers installed in conference rooms and interconnected by an audio transmission facility.

A picture may be worth a thousand words, except in a remote meeting situation. Here, only a handful of unintelligible words will send the participants back to the airports. The complications arise mainly from the need to satisfy the user-acceptance criteria. This usually dictates the use of full-duplex audio connections, with open microphones, such that participants can react normally, without using much overt action such as push-to-talk, or holding handsets.

Open channels bring the three deadly "R's"—room noise, reverberation, and return echo.

\* In particular, an experimental audio facsimile system has been in operation for over one year between the RCA Laboratories, Princeton and RCA Consumer Electronics, Indianapolis.

As shown in Fig. 1, machines (facsimile, projectors, air conditioners) usually create ambient noise. These sounds tend to mask the talker's voice signal. The amount of room noise determines the maximum allowable separation,  $D_n$ , from the talker to the microphone.

Another maximum allowable talker-to-microphone distance,  $D_r$ , is determined by the room reverberation. The reverberation, caused by echos and reflections within the room, creates a hollow-sounding voice to the remote listeners.

The distances  $D_n$  and  $D_r$  can be separately calculated, and the smaller of the two used to position microphones.

Return echo is akin to reverberation in that the sound from loudspeakers can acoustically couple (directly and from flutter echos) into the microphone at the same conference room. The sound thus returns to the originating conference site, and is perceived as an echo.

## Noise level considerations

The maximum microphone-to-talker distance is limited by ambient noise. As the distance increases the noise output of the microphone remains the same, but the voice output becomes less until the ratio is unsatisfactory. The average talker sound pressure level (SPC) is 70 dB at a distance of three feet. Figure 2 shows the maximum distance between a talker and a

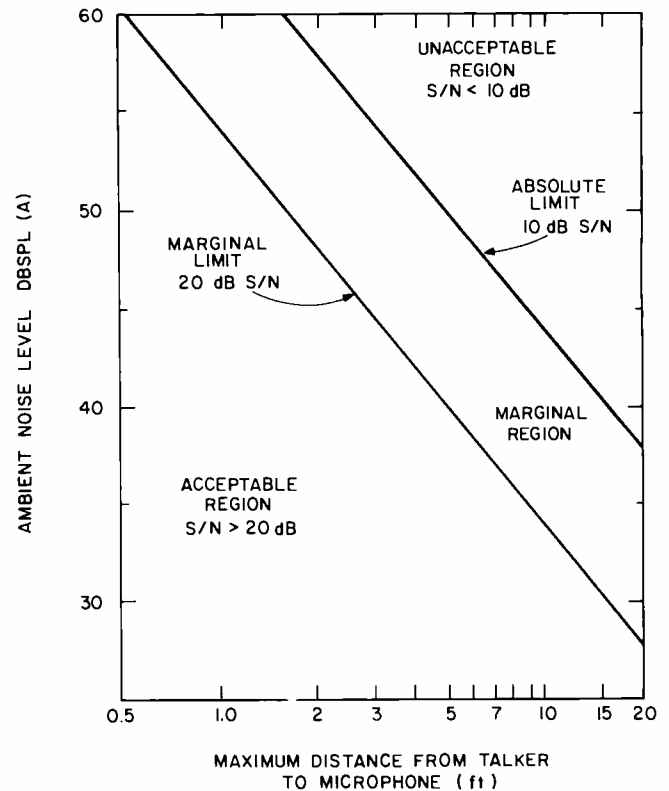


Fig. 2. Microphone/talker separation.

microphone that ensures a signal-to-noise ratio of 20 dB, after a correction of 5 dB to account for F1A weighting. This is found to be marginally acceptable in transmitted speech. To use this graph, the noise measurement should be performed at the conference table with equipment in the room in normal operation. For the measurement, Type A frequency weighting is used.

Figure 2 applies to a single omnidirectional microphone. If directional (cardioid) microphones are used, the indicated distance can be increased by 50 percent. But if more than one microphone is active at the same time, then the amount of room noise picked up and transmitted will increase. A useful approximation of this increase is based upon the assumption that the noise level will rise 3 dB each time the number of microphones is doubled. This increase in the effective noise level should be taken into consideration before using the graph to determine the maximum distance.

## Reverberation considerations

Room reverberation is mainly caused by flutter echoes between parallel walls and reflections from objects. When a microphone is close to the talker, the greatest percentage of picked-up sound comes directly from the talker, and

reverberation in the room exerts relatively little influence. As the distance between the talker and the microphone increases, the direct sound level reaching the microphone decreases 6 dB for each doubling of distance, whereas the average level of reverberant sound remains nearly constant. As the ratio of direct-to-reverberant sound energy decreases with increasing separation, the speech reproduced at the distant point becomes less intelligible. In effect, it acquires the hollow "rain barrel" effect.

The reverberant sound picked up by the microphone relative to the direct sound energy depends on the following: the room's size and shape; acoustic properties of the room (scattering and absorption); and microphone/talker separation and directionality.

In most teleconferencing situations, there is limited control over the room's size and shape. Therefore, the problem must be considered from the other two factors.

When dealing with either the room acoustics or the microphone placement, the first step is to calculate the average absorption coefficient of the room. Each surface in a room has an absorption coefficient ( $A$ ) that is the ratio of the energy absorbed to the total energy reaching the surface. The absorption, expressed in absorption units, is the product of the absorption coefficient and the given surface area. The total absorption in a room is the sum of the absorption units contributed by all surfaces (walls, tables, etc.) and all objects (people, chairs, etc.) that absorb sound. That is, the total absorption is  $\sum A_i S_i$ , where  $A_i$  is the absorption coefficient of an object with surface area  $S_i$ . The average absorption coefficient is the total absorption in a room divided by the total surface area, namely

$$A_{av} = \frac{\sum_i A_i S_i}{\sum_i S_i} \quad (1)$$

The acoustic properties of a room can be defined in terms of reverberation time, the time required for a suddenly interrupted sound to decay to a level 60-dB below the original sound. Reverberation time is formulated<sup>1</sup> as

$$T = \frac{0.05 V}{S \log_e(1 - A_{av})} \quad (2)$$

where  $V$  is the room volume (cu. ft.);  $S$  is the total surface area (sq. ft.); and  $A_{av}$  is given by equation (1).

In general, reverberation times of one second or less provide intelligibility of 95

percent or better. If the reverberation time from equation (2) is found unsuitable, then the room acoustics can be modified (drapes, baffles, etc.) to reflect a better average absorption coefficient.

Given a room with poor reverberation time, and which cannot be easily sound-treated, the only mechanism is to control the talker/microphone separation. The critical distance concept found in the literature<sup>2</sup> offers a solution. This distance is defined as the separation from a sound source at which the direct energy from the source equals the reverberant energy reflected from all room surfaces. Mathematically, the critical distance is defined as

$$D_c = \left( \frac{0.02 A_{av} S}{1 - A_{av}} \right)^{1/2} \quad (3)$$

where  $S$  is the total room area, and  $A_{av}$  is defined by equation (1). Empirical study shows that good performance is achieved if the microphones are placed no more than half the critical distance from talkers. When directional microphones are used, the separation may be increased to  $0.75 D_c$ .

The results of equation (3) may define distances which are impractically small. In this case, either lavalier microphones can be used, or sound treatment employed.

## Microphone type and placement

From ambient noise considerations, the microphone to talker distance must be less than the distance determined from Fig. 2 to ensure adequate signal-to-noise ratio. When directional microphones are used, the maximum microphone-to-talker distance can be increased by 50 percent.

From reverberation considerations, the microphone-to-talker separation must be less than half the critical distance to ensure intelligible, easily-recognizable, non-reverberant speech. When directional microphones are used, the maximum microphone-to-talker distance can be increased to  $0.75 D_c$ .

For good sound pickup, the microphones must be placed to satisfy both the above rules. In other words, the microphone-to-talker distance must be less than the smaller of the two distances.

## Echo considerations

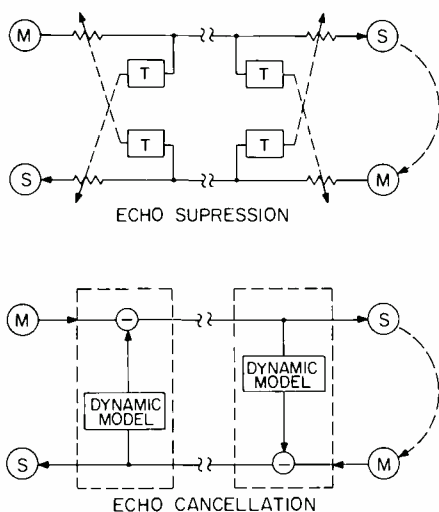
Even with attention given to the selection of directional microphones, room sound absorption and speaker placement, it is

quite likely that sound radiated from the loudspeaker of the conferencing unit will find its way into a conference microphone at a significant strength, at least at some frequencies. This path from loud speaker to microphone allows sounds received at a distant conference room to return to the originating conference room. Because of the time delay in the interconnecting telephone lines in addition to the delay of the acoustic path through the receiving conference room, the returned sound is perceived by the talker as an echo. This returned sound becomes more or less of an annoyance to the person talking depending upon the strength of the echo and its delay.

Even more serious than the annoyance is the possibility of "howling," where an amplified sound repeatedly travels from speaker to microphone at both conference locations. This feedback sets up a loud, sustained tone oscillation heard at both locations. This can happen in a properly functioning conference system when a directional microphone is turned toward the loudspeaker at one location. The same may also happen if a conference participant moves close to his microphone—perhaps leans over it, or tries to cover it with his hand. This action significantly increases the microphone's response to a particular frequency, enabling the system to oscillate.

Since the return echo is related to so many uncontrollable factors, external devices are usually employed to combat the problem.

An echo-suppressing device providing help toward reducing the echo effects was developed for telephone service. The echo suppressor is distinguished from the echo canceller that will be discussed later. As related to electronic conferencing, shown in Fig. 3, the echo suppressor examines the amplitudes of the signals coming into a conference speaker,  $S$ , and those leaving via the microphone,  $M$ . If a normal strength signal is arriving from the distant conference room while a moderately weak signal is being sent out, a threshold circuit,  $T$ , "decides" that no one speaking locally and that the weak out-going signal is the result of the received signal being turned around, that is, echoed. The suppressor then proceeds to attenuate the outgoing signal to prevent the echo from returning to its source and disturbing the talker. If a normal intensity outgoing signal is found simultaneously with a normal intensity incoming signal, however, the echo suppressor "decides" both parties are speaking (double talk) and it then proceeds to remove the attenuation from the outgoing



**Fig. 3. Suppression and cancellation.**

signal (so that the near talker can be heard at the other location) and to introduce some attenuation (4-dB or so) into the incoming path to attenuate the echo produced at the far location.

Of course, this action reduces the sound of the other talker's voice, but the double-talk condition is usually only a temporary interruption.

During conversations, the echo suppressor causes frequent changes in gain that show corresponding changes in the background noise coming in from the far end. Talkers usually find these changes in the background noise disturbing, but less so than unsuppressed echos being suppressed. Those in the room with the talker, however, are especially conscious of the sound from the loudspeaker changing between the talker's words. These and other inherent shortcomings of the echo suppressor promoted a search for better alternatives.

A fresh attack on the echo problem produced the more sophisticated device called an echo canceller, also shown in Fig. 3. This device incorporates both analog and digital processing to effectively cancel echos. The echo canceller examines both the receive and send signals as does the echo suppressor. But the examination is addressed to defining the characteristics of the echo path. The impulse response of the echo path is determined and stored in a digital memory. The incoming signal is fed to a convolution processor that makes use of the stored impulse response to generate a replica of the echo signal. The model-generated echo is then subtracted from the outgoing signal, thereby cancelling the echo component portion of the transmitted output signal.

The early echo cancellers obtained the

impulse response of the echo path by probing the path and storing it in a digital memory. The system worked quite well for time-invariant echo paths, but any response changes occurring after storing the impulse response rendered the generated echo model inaccurate, and less effective echo-cancellation resulted. In a conference environment, people will continually move about within the proximity of the microphones and perhaps rearrange the microphones themselves. Only by probing the echo path repeatedly can a moderately accurate impulse response be maintained. Improved designs of echo cancellers model the echo path with a transversal filter using a tapped delay line in which the coefficients of the impulse response are automatically and continuously adjusted during the course of a conversation so as to minimize the RMS value of the uncancelled echo. An echo reduction of 22-dB is possible with such adaptive systems.

Echo cancellers of the latter type have been very successfully used in an experimental Audio Conference system between RCA Laboratories, Princeton and RCA Consumer Electronics, Indianapolis.

## Video systems

As previously mentioned, video teleconferencing systems are a giant step in improving the feeling of "presence," and enlarging upon the interactivity between separated groups. Video techniques must be carefully considered to effect a compromise between maximizing the amount of information (in allowable conventional bandwidths) while minimizing the equipment costs. This section presents some of the video generation and display tech-

niques developed at the Laboratories that achieve this goal.

## Basic methods video generation and display

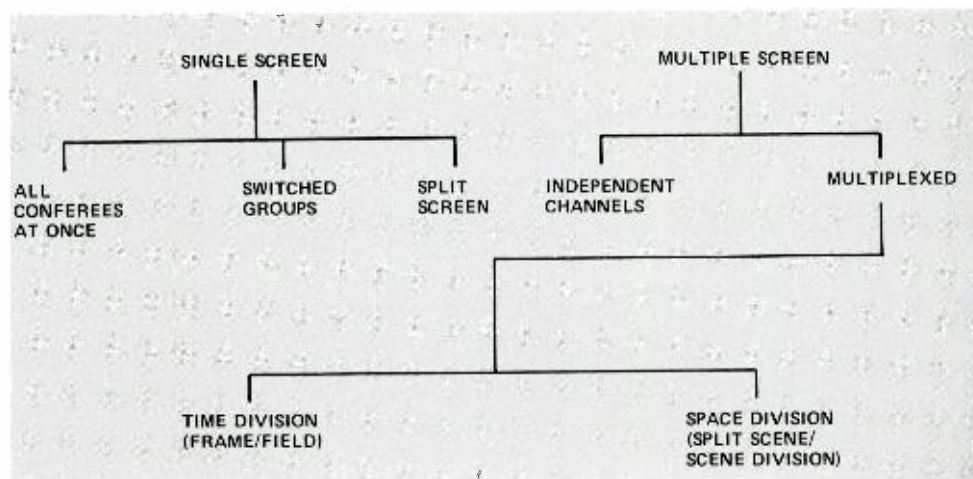
Video generation and display (conference studio techniques), and transmission are interrelated. For teleconferencing, there is more latitude in the former. That is to say, video teleconferencing can take advantage of tradeoffs (within acceptable tolerable limits) of motion rendition, resolution, received signal-to-noise and other special visual effects which the rigorous specifications of broadcast television, for example, would not otherwise allow.

These tradeoffs permit simpler, more cost-effective video systems that are better tailored to teleconferencing use. As noted, the methods of picture display can increase the efficient use of the channel, as well as bear strongly on the factors of facial contact and expression, and the feeling of presence which is important for successful remote conferencing.

The choice of video generation and display mechanisms suggests a tree as shown in Fig. 4. There are two basic starting premises for display: single screen and multiple screen. The following text traces through the tree to analyze the impact of display upon the video generation technique.

### Single-screen technique

If the receiver site is restricted to have only a single display device, then the practical methods to accommodate this requirement are those of fixed group, switched groups and split screen. These will be discussed next.



**Fig. 4. Picture display methods.**

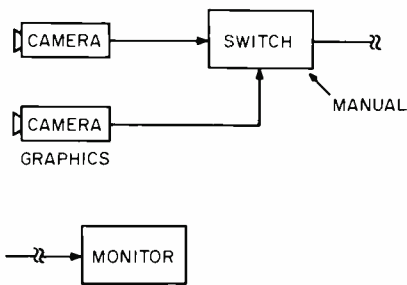


Fig. 5. Simple "all conferees" system.

*Fixed Group*—Within the restrictions of single monitor screen at the receiver, the simplest, most straightforward manner is to display all the conferees in one field of view, with manual switching to a graphics camera as needed (Fig. 5). But past experiences in teleconferencing have shown that facial definitions and expressions are subjectively important factors in the successful acceptance of a teleconferencing system. In fact, more than three or four adjacently seated conferees exceeds the limits of facial definition and eye contact. Therefore, the single-view display would only be practical in conferences of four or less people, and would seem to be quite restrictive.

*Switched Groups*—One method of overcoming some of the previously noted disadvantages is to have several cameras focussed on small groups of conferees. Preferably, the subgroup size would be limited to three or less persons such that, for example, a conference of nine people would typically have three cameras (Fig. 6). The camera selected for transmission could, of course, be done manually by an operator, although most of the existing experimental conference systems use voice switching as shown. That is, the camera choice is automatically governed by the audio level emanating from a particular group. The philosophy of voice switching has drawbacks, particularly from a systems point of view. These include: visual disturbances of switching; threshold settings and appropriate hang-over times; viewer confusion due to repeated switching during exchanges between people from different groups; inadvertant switching (coughing, aside conversations; and system indecisions due to simultaneous talk and silence.

*Split Screen*—A good compromise between the previous fixed and switched groups, and perhaps the most economical approach to multiple video for teleconferencing, is the split-screen or scene-division technique. Calculations have shown that for field of view of three people sitting side by side, somewhat less

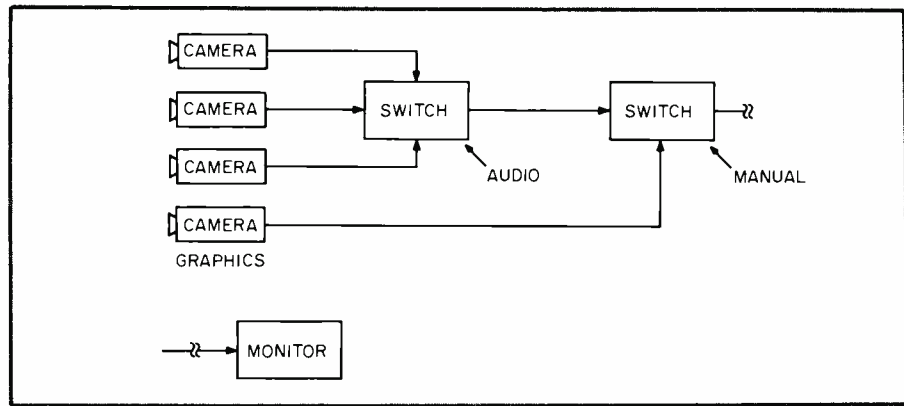


Fig. 6. Voice switched system.

than half the scene is the conferees themselves. The rest of the scene will be the table bottom and the wall. Therefore, it is reasonable to assume that a half of the field, and three other conferees will be in the bottom half of the field (Fig. 7). The intrinsic difficulty in this approach is one of subjectivity at the receive side. With a single monitor, the displayed image must be left composed, in which case the remote conferees will appear to be sitting in a tiered arrangement. But this method allows the benefits of continuous view with good facial resolution of six-to-eight conferees, without the confusion of camera switching.

The natural restriction of six-to-eight total active participants is not necessarily a very bad outcome since statistics show that only 20 percent of conferences have more than six people, and only 10 percent have more than eight active people.

### Multiple-screen techniques

Allowing more than one monitor at the receive side of course leads to a greater variety of techniques for conferee image presentation. The caveat here is that past experimentation has shown that forcing a view of more than two monitors is visually disturbing and leads to unacceptability in terms of viewing direction and eye contact maintenance. Because of this, the discussion will concentrate on techniques involving two monitors. The ideal solution to practically all of the previous single-screen problems is to partition the conferees into subgroups (typically three conferees in each group) and transmit each group image continually. Of course, even for the minimal case of two cameras, independent channels are extravagant in terms of transmission bandwidth. But multiplexing

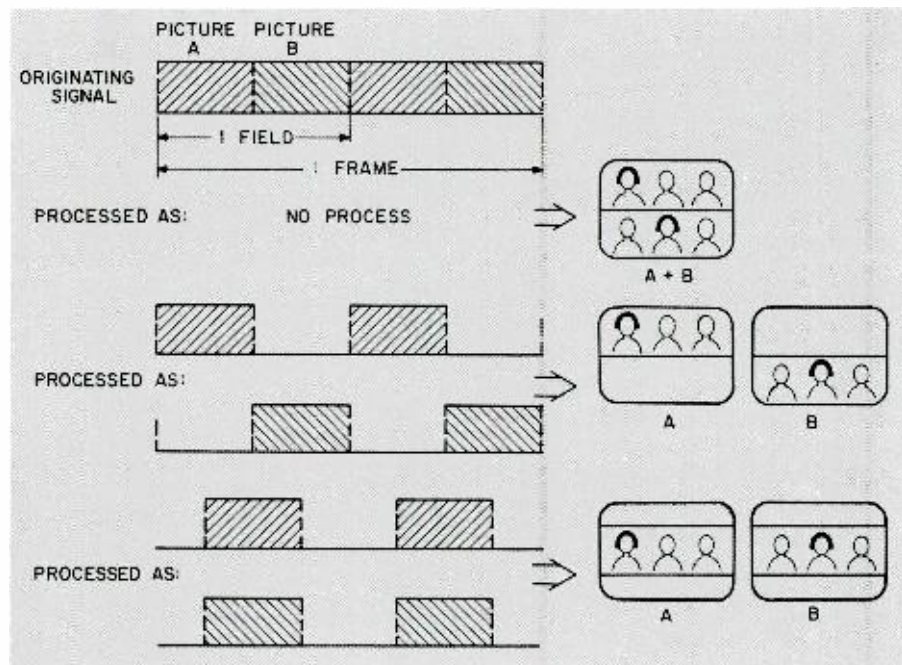


Fig. 7. Scene separation techniques.

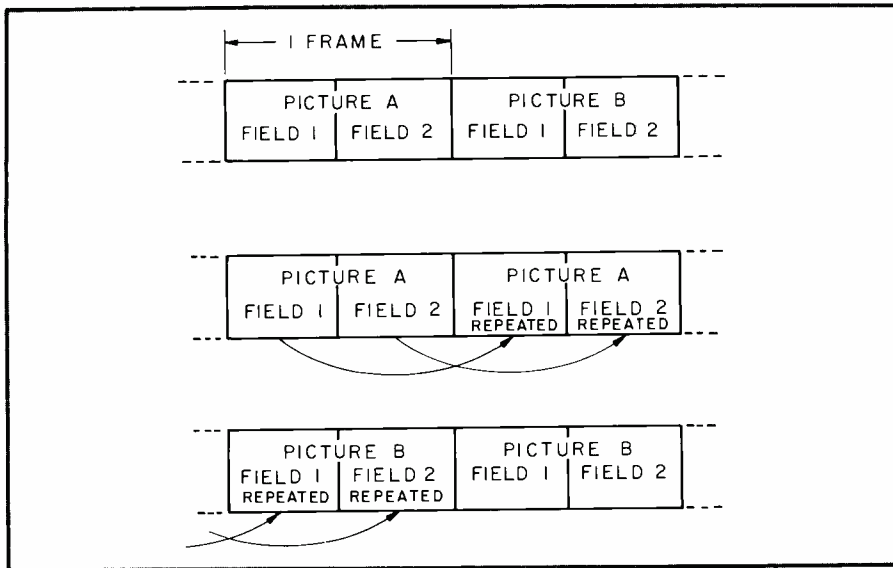


Fig. 8. Alternate frame multiplexing and frame repeat demultiplexing.

techniques that use field interpolation and/or frame-repeat mechanisms give the appearance of multiple channel signal occupancy while actually only using single TV channel bandwidths. In any event, the requirement of not using appreciably more transmission bandwidth for two TV signals than would ordinarily accrue to one TV channel is the governing requirement. Techniques for fulfilling this requirement are discussed next.

**Field/frame Division**—A multiplexing technique for consideration is the time division of fields, or frames, from two independent locked video sources. Previous programs at RCA Laboratories have evaluated field interleaved systems. In these systems, the odd fields from one source are time multiplexed with the even fields of another (two cameras focussed on two conferee groups, for example). At the receiver, the fields are separated, and the missing fields are interpolated using field storage and comb filtering. Such equipment results in the loss of both motion rendition and resolution, each to some extent. Furthermore, the equipment is relatively expensive. For teleconferencing use, motion rendition (seated people) is secondary in importance to resolution (charts, graphics, etc.). Therefore, it seems that frame multiplexing is more appropriate for teleconferencing. The concept is that alternate frames from two sources are time multiplexed. Since the frames are each fully interlaced, obtainable resolution is available. The recovery of the missing frames can either be done by interpolation (with suitable storage) or simple repetition of the previous frame, as shown in Fig. 8.

**Scene Division**—As noted in the discussion of split-screen transmission, the subjective difficulty with one monitor was the necessity to leave the scene in composite form at the receiver. But dividing the composed video into the individual scenes for independent display or two monitors is completely feasible. In this case (referring again to Fig. 7), the scenes can be simply separated—appearing on the upper and lower halves of two monitors—the scenes can be suitably shifted down and up respectively to provide center-screen luminance, and indeed give the impression of side-by-side seated conference participants.

**Graphics**—Although the discussion so far has concentrated on the visual presentation of conference participants, a significant part of group meetings involve graphic presentations of charts and other visual aids. In the single-screen cases, the graphic visuals must of necessity replace the conferee images during presentation. But, with multiplexing techniques, it is possible to interleave the graphics video with that of the participants. It is enjoyable to consider marriage of field/frame interleaving of graphics and participants with a scene division of the conferees such that *all* the remote group *and* the graphics could be viewed simultaneously—which is most like face-to-face meetings.

## Evolving a total video system

The systematic evolution of a video conference system, and one which allows modular growth, is shown in the series of diagrams of Fig. 9. The cross-hatched

blocks are those which are added in the growth process.

Figure 9a is the basic system for scene dividing two groups of three participants each, and allows for manual insertion of graphics. Notice that the receive monitor leaves the participant view in a tiered arrangement.

Figure 9b shows the option of dividing the scenes at the receiver onto side-by-side monitors.

The next step is to multiplex the graphics and the participant scene using time division based on frame selection. Now, the receive system allows viewing participants and graphics simultaneously, as shown in Fig. 9c.

The last stage, which is also optional incorporates a scene division switch at the receiver to separate the tiered participants into side-by-side monitors (Fig. 9d).

## Summary

In terms of audio for teleconferencing, people are pre-conditioned to accept telephone quality in terms of frequency bandlimiting. But care must be taken in the choice of a conference room in terms of noise level and reverberant properties. Acoustic treatment or at least one of two parallel surfaces, and awareness of the echo problems when placing microphones and loudspeakers are significant factors.

Based upon the results of past research, video teleconferencing has its own special requirements—namely, good facial definition of participants, high resolution for graphics, with relatively little emphasis on motion rendition.

Toward these ends, split-scene techniques maximize the number of conferees without the attendant problems of voice switching. Subjective tests have shown the efficacy of this method in presenting a continuous view of up to eight individuals. Scene division can be made by minor modifications of off-the-self video processing systems and presents a “normal” display of adjacently-seated participants (if desired).

The subjective response of a small sample group indicates that splitting the scene onto two monitors is more desirable than leaving the split scene composed on one monitor, and that in-line shifting of the scenes was optimum. In addition, masking upper and lower quarters of the blanked raster obviated the oftentimes-mistaken impression of monitor malfunction.

In split scene, the view of participants, and other forms of video (for example,



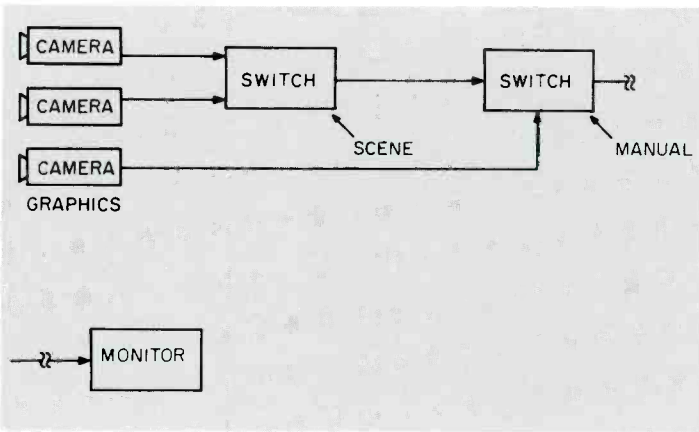


Fig. 9a. Scene interleaved basic system.

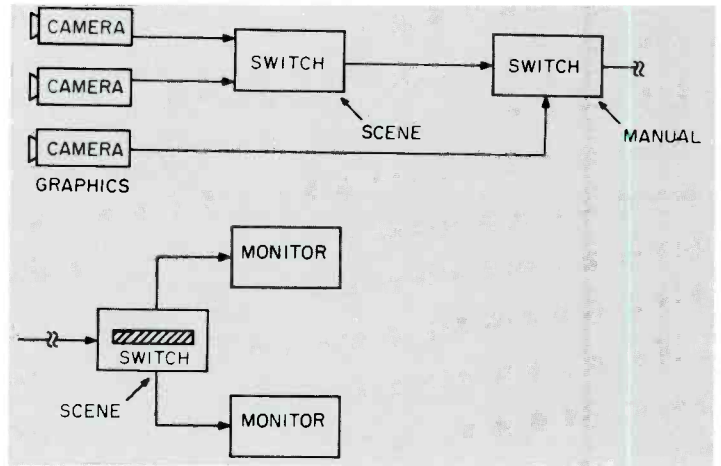


Fig. 9b. Optional scene separation at receiver.

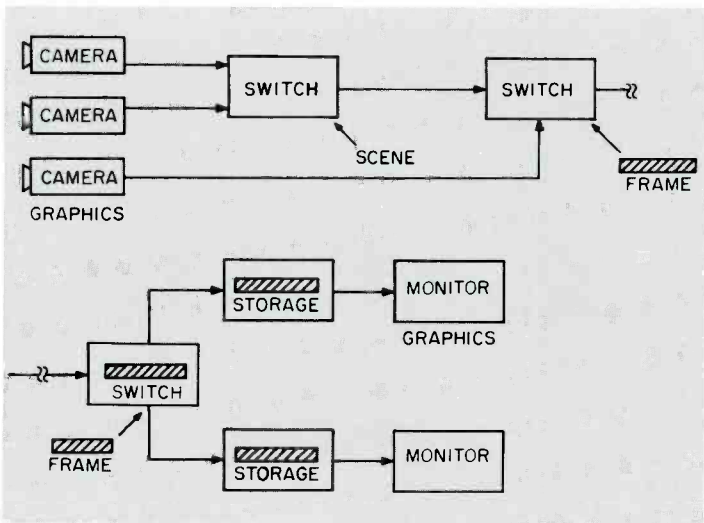


Fig. 9c. Scene interleaving and frame multiplexing.

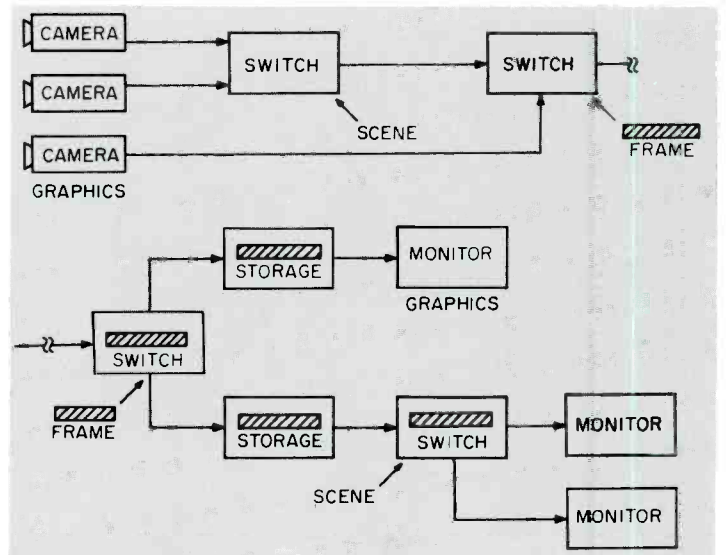


Fig. 9d. A complete system.

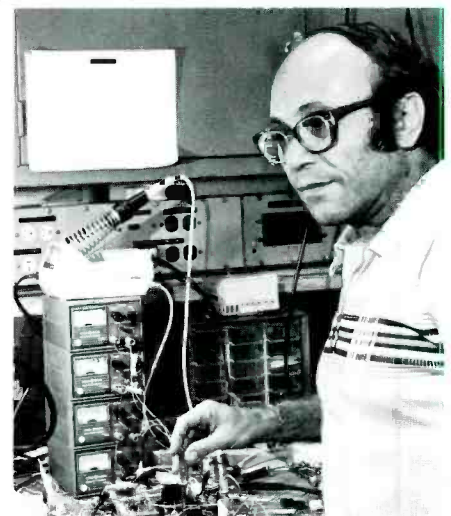
graphics), can be multiplexed on a field or frame basis. In particular, frame multiplexing offers better resolution when compared to field interleaving, and motion rendition is adequate for conference room scenes. Subjective tests show that a one-frame update in three succeeds. Lip synchronization is the predominant adverse effect if more than three sources are multiplexed.

## References

1. Watson, F.R., *Acoustics of Buildings*, 3rd ed., John Wiley & Sons, New York (1941).
2. Bell System Voice Communications Technical Reference, *Acoustics of Teleconference Rooms*, PUB 42901 (1977).

**Alfonse Acampora** joined the RCA Advanced Communications Laboratory in New York City, where he helped to develop military communications systems. After two years with the General Telephone and Electronics Research Laboratory in Bayside, New York, Mr. Acampora re-joined RCA in 1970 at the Global Communications facility. He received the David Sarnoff Outstanding Achievement Award in 1973 for his work in narrowband video systems. In 1978, Mr. Acampora joined RCA Laboratories. He is currently involved in both digital and analog signal processing systems, video bandwidth compression and satellite technology.

Contact him at:  
**RCA Laboratories**  
**Princeton, N.J.**  
**TACNET: 226-2773**



# Cable television, an overview of technology

*In 1980, RCA Cablevision Systems doubled the size of its new-product development staff in an effort to develop new 400-MHz cable amplifiers; addressable, digital technologies for subscriber devices; and system monitoring.*

---

**Abstract:** *This article reviews the current technology in the cable television industry and touches on new-product development at RCA Cablevision Systems. It covers headend equipment, continues with descriptions of the distribution of the signals to the subscriber and the subscriber-interface equipment, and concludes with a forecast of future trends in the technology.*

---

Cable television (CATV) is one of the most rapidly growing areas in the communications field. There are currently over 16-million CATV subscribers, up from 15 million only six months ago. The rate of growth has also been increasing. The primary reason for this expansion is the availability of premium programming. Various packages are available on the cable featuring first-run movies, material for children and special-interest groups, news, religion, sports events and independent TV broadcast stations such as WGN and WTCG. All of this additional programming is carried, via satellite such as RCA Satcom, to any CATV system that desires it. The marketability of this material has allowed cable television to penetrate major urban areas on a profitable basis. Before, there was little programming to attract customers in a major market area that already had six to twelve or more channels available off the air. This formally

restricted cable to the more traditional fringe area or the small community with little or no broadcast television.

The additional premium programming now carried on many cable systems is provided on a pay or extra-fee basis. This introduces the need for signal security and for a method that handles incremental billing. Thus, various schemes for electronically scrambling signals and addressing individual subscribers are beginning to appear. In the future, this equipment will evolve into more sophisticated subscriber terminals that will "talk-back" and will allow additional services over the cable such as home-security alarms, in-home shopping, opinion polling, pay-per-view programming, frame-grabbing from a central library of information, banking from the home and similar services. Also, a continuing trend to wider system radio frequency (RF) bandwidth means that additional channels can be added.

To meet the challenges of this growing industry, RCA Cablevision Systems is expanding its research and development activity. In 1980, Cablevision doubled the size of its new-product development staff and moved to larger facilities at its Van Nuys, California plant. Further expansion is planned for 1981 and later. One of the major growth areas is in addressable, digital technology for subscriber devices and system monitoring. This digital technology represents the greatest opportunity for expanding our market. Additional development is also underway to produce the next generation of headend and distribution equipment.

## Headend equipment and systems

### Signal sources

A CATV headend serves as the summing point of the signal sources in the cable system. Various signal sources are collected at the headend, processed and conditioned as required, normalized in signal level, then combined by frequency-division multiplexing and fed into the downstream cable path. Signal sources arrive at the headend in various forms, including VHF, UHF, microwave and baseband.

These sources normally include off-air VHF and UHF television, FM-band signals, and may include microwave sources supplied by the terrestrial CARS (community antenna relay station) band and satellite-to-TVRO (television receive-only) transmission. UHF-TV channels require conversion to the 54-300 MHz spectrum, and VHF-TV may require off-channel conversion.

Microwave signal sources generally arrive at the CATV headend as baseband video and audio signals. Locally originated program sources normally are fed to the headend as baseband video and audio. Program sources may be studio camera, videotape, time-weather service, slow-scan news, or demodulated sublow band upstream cable signals that require remodulation and reinsertion into the downstream signal path at 54-300 MHz.

Various processing techniques are required to condition these signals for use on

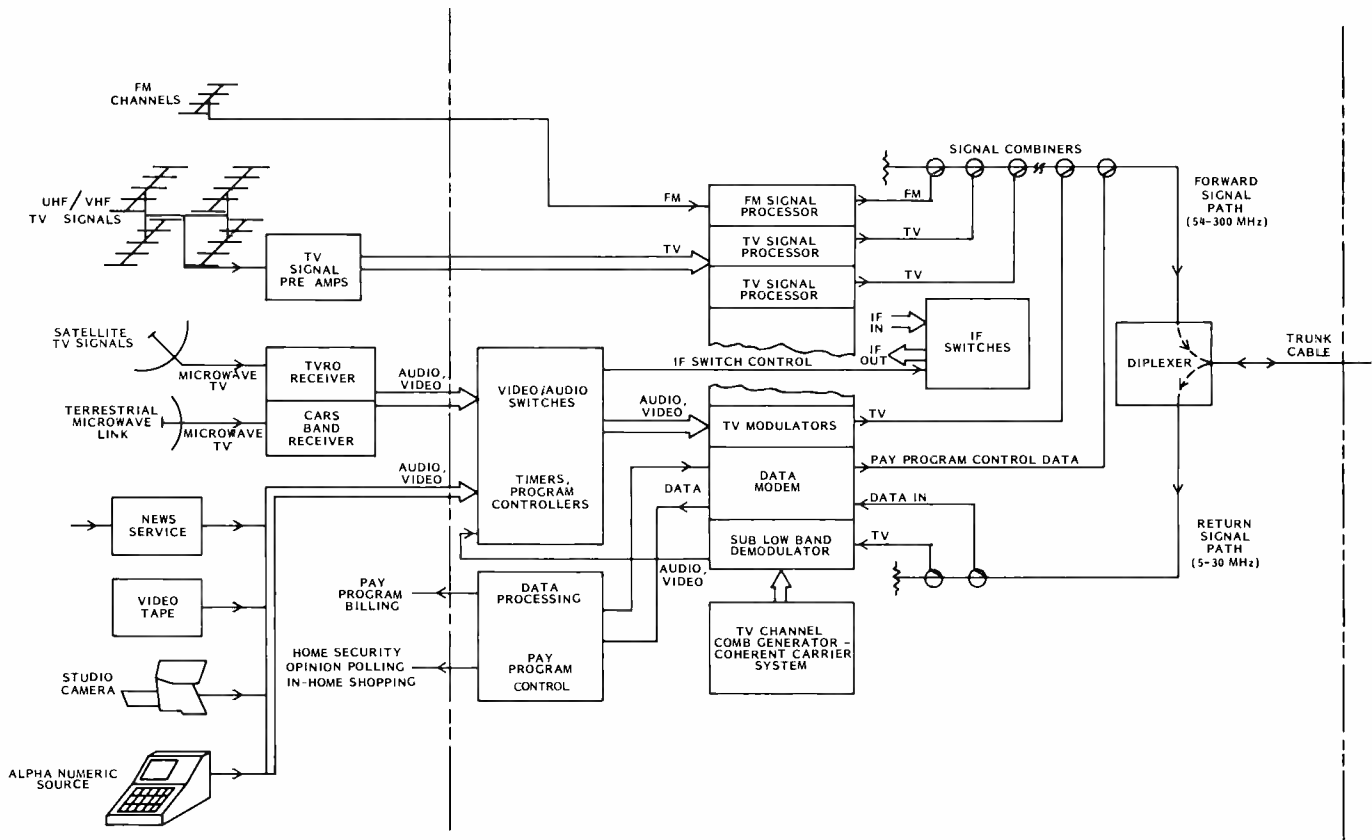


Fig. 1. Typical full-service CATV headend.

cable systems. Figure 1 illustrates a CATV headend, including these signal sources and various processing methods.

FM-band signals are normally carried on the cable 15-dB lower than TV-picture carriers. Single-channel FM-band processors provide good spectrum control and allow individual channel-level control. Block processing of the 88-108 MHz FM band provides a low-cost alternative to single-channel processing, at the expense of losing individual and automatic control of carrier levels.

VHF-TV signals are typically received with single-channel YAGI antennas or low-band/high-band log-periodic antennas. Vertical and horizontally-stacked antenna arrays often are used to increase pattern gain or to achieve specific pattern shaping. Antenna placement within the array can achieve pattern nulls to reduce co-channel pickup. Antenna, downlead, and load voltage standing wave ratio (VSWR) must be well controlled across a channel width to minimize mismatch echoes and subsequent ghosting. Low-noise preamplifiers installed at the antenna may be used for distant signals.

A heterodyne signal processor serves as the normal conditioning and interface device between the VHF/UHF off-air

signals and the cable transportation system. Signal amplification, level-normalizing AGC, aural-carrier-level control and channel conversion (if required) are primary functions of the signal processor. Internally generated substitution picture and sound carriers may be actuated remotely or automatically with carrier loss or with severe signal fade.

Intermediate frequency (IF) signal switching into the signal processor's IF system allows alternate program substitution on a given channel. IF-output and switched IF-input ports are features normally available in signal processors.

Baseband signal sources represent an ever-increasing percentage of program material carried on cable. Pay-TV programs and other special cable services generally are represented as baseband signal sources at the headend. Locally originating programs may be derived from videotape, studio cameras and alphanumeric displays. Each of these sources require translation from baseband to an assigned channel frequency.

Distant TV channels imported by terrestrial microwave and satellite-to-earth-station TVRO signals arrive at the headend as baseband video and audio, and also require translation to an assigned

channel. CATV modulators provide this translation from baseband to a TV channel. Compatibility in the cable system requires modulation characteristics similar to those of a broadcast-TV transmitter. Auxiliary features within the modulator may include carrier phase-lock capability and IF switching for signal substitution.

### Interference and distortion

The ingress of off-air broadcast signals into the cable's signal path or direct pickup by TV receivers may cause interference that would preclude use of that channel. Whenever possible, signal carriage is maintained on-channel to minimize off-air pickup between desired and undesired signals. Operating the off-channel cable signals phase-locked to a sample of the off-air co-channel signal will "zero beat" the carriers and can offer up to 20-dB improvement in the perceptibility of the interfering signal.

Mutual interference between channels results from third-order distortion, creating cross-modulation and intermodulation noise within the system. Third-order intermodulation noise can be largely eliminated through coherent carrier operation whereby channel-to-channel picture-

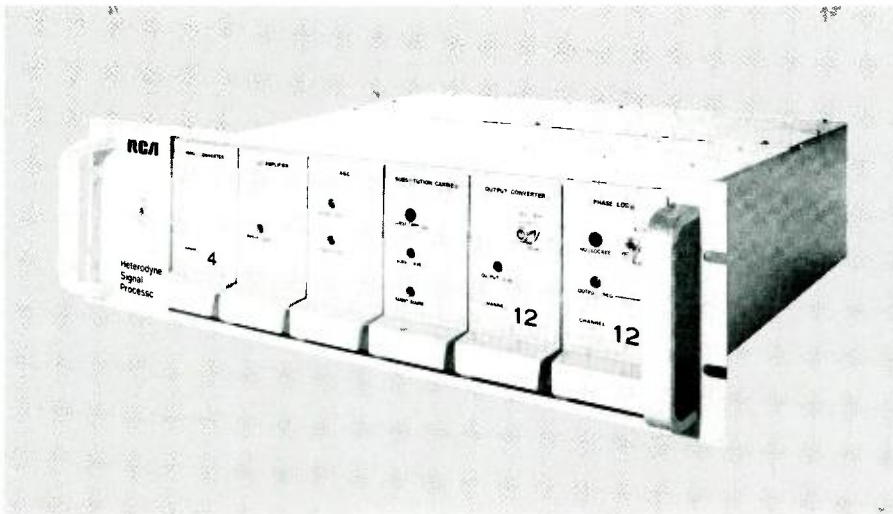


Fig. 2. Signal processor.

carrier spacing is established by identical 6-MHz increments. A CW-carrier comb generator having stable and contiguous 6-MHz-increment outputs located within the headend may be used to provide a phase-lock reference carrier to the headend units.

### Program switching

System requirements for nonduplicative signal transfer, emergency-alert messages, and automatic program substitution with carrier loss mean that some form of signal switching within the headend must be used. Switching may be integral to the headend units or may be done externally with discrete switching, and may be baseband, IF or on-channel. Internal IF switching provides mutual switching compatibility between modulators and signal processors, and it generally is the preferred switching method.

### Signal combining

Once processed and made "cable ready," signal sources are frequency-division multiplexed into the cable's trunk input with passive directional couplers. Picture and sound carriers are individually adjusted to the proper level balance. FM-band and TV-sound carriers are normally carried 15-dB below picture carriers to minimize the sound carriers' contribution to system distortion and overload.

Bidirectional CATV systems use a duplexing network to separate upstream path signals from the downstream cable transportation. Processing of the return path upstream signals may take the form of demodulation to baseband video and

audio, or conversion to a downstream channel for reinsertion into the upstream cable path. CATV demodulators are available for this function, and for monitoring and diagnosing the cable signals. Demodulators are also used for remote site off-air signal pickup prior to being transported by microwave link to a headend site.

### RCA headend products

RCA currently manufactures a complete line of CATV headend products including the HSP1 signal processor, CTM10 modulator and CTD10 demodulator. The HSP1 is typical and will be discussed briefly.

The signal processor is a solid-state heterodyne unit designed for cable headend applications. The modularly designed unit has six front-panel plug-in modules: an input converter, an IF amplifier, an AGC, a substitution carrier, an output converter and a phase lock (Fig. 2). The chassis main frame houses the power supply, IF filter and traps, IF switching circuits, and all module interconnect wiring and connectors. The processor's design allows optional features and accessories to be easily added to the basic unit. The basic packaging concept of the signal processor is carried throughout the entire headend product line.

### Distribution equipment and systems

The CATV distribution system provides the means for transporting the signals from the headend to the subscriber. The signals

are carried over coaxial cable. They go through repeater amplifiers which amplify the signals to overcome the attenuation of the cable. The basic system is composed of trunk and sub-trunk lines that form a network to cover the area to be served. There can be several trunk lines from a headend and these are generally the longest cascade of amplifiers. Cascades of 20 amplifiers are typical of most systems but they are sometimes much greater.

The sub-trunk lines are split off the main trunk lines to cover remote areas or areas between any two trunk lines. The trunk amplifiers are typically spaced one half-mile apart using coaxial cable that is 0.750 inches in diameter. The amplifiers are powered through the cable with 60 VAC.

### Trunk amplifiers

The heart of the amplifier is a state-of-the-art hybrid module specifically made for CATV applications. A typical trunk amplifier will amplify from 54 to 300 MHz with a flatness across this frequency band of  $\pm 0.1$  dB or less.

Typical requirements of a trunk amplifier other than amplifications are:

- Bandwidth of 54-300 MHz with present development expanding the bandwidth to 400-MHz;
- Channel capacity of 36 video channels plus 100 FM channels (expanding to 54 video channels with 400 MHz);
- Environmentally sealed housing and RFI protection over a temperature range of  $-40^{\circ}$  F to  $+140^{\circ}$  F;
- Equalization for the cable attenuation since the attenuation is greater at higher frequencies;
- Automatic gain and slope equalization control to correct for level changes due to temperature effects on cable attenuation;
- Power supply to provide dc voltage to the various circuits, plus power direction to route the ac voltage through the amplifier to power the next trunk;
- Surge and lightning protection;
- Bidirectional capability. Present amplifiers incorporate duplex filters and a reverse amplifier to provide a 5- to 30-MHz return path to the headend over the same cable; and
- Trunk amplifiers may also have optional features such as remote activation of switches in the reverse amplifier and monitoring systems in each amplifier to check voltages and levels and to transmit this data back to the headend.

### *Bridger amplifier*

The trunk amplifiers transport the signals through the system. But the system uses a bridger amplifier to distribute signals to subscribers. Since the trunk line is usually a long cascade, any in-line breaks are minimized to prevent irregularities in the amplitude of the response. The trunk amplifier incorporates a directional coupler, which is a transformer with high isolation, to tap off a portion of the signal. Another amplifier then raises the level of the signal for distribution. This amplifier is called a bridger amplifier because it bridges between the trunk line, and the "feeder lines" that distribute the signal to the subscriber.

The bridger amplifier is incorporated in the same housing as the trunk module, AGC and power supply. The bridger amplifier has a distribution splitter that has from one to four outputs (feeder lines). As the signal is attenuated along the feeder lines, it must be reamplified periodically in order to extend the feeder lines. Figure 3 is a photograph of a bridger-trunk amplifier.

### *Line extender*

The line extender is a high-performance, inexpensive amplifier used to extend the feeder lines. The amplifier, power supply and reverse amplifier are usually built on a single printed circuit board to minimize cost. The stringent response flatness required in the trunk amplifier is unnecessary in the line extender because the cascades of line extenders are normally limited to two amplifiers. An AGC option is also available in the line extender.

### *Passives*

Splitters and directional couplers are passive devices used in a system to split the trunk line or feeder lines. Directional couplers or taps are used in the feeder lines to feed the signal to the subscriber and provide isolation between subscribers.

### *System performance*

The system is limited by two major distortions. The trunk cascade is limited by the required carrier-to-noise ratio (C/N) and the bridger and line-extender output levels are limited by third-order intermodulation, (composite triple beat). The trunk levels are selected to achieve the desired C/N for the required cascade to cover the area to be served. The bridger and

line-extender levels are operated as high as possible to overcome the losses of the passive devices in the feeder lines and to minimize the cost of the system.

### *Carrier-to-noise ratio (C/N)*

The C/N is defined as the ratio between the video-carrier signal level and the RMS noise level. The ratio is expressed in decibels. The threshold of perceptibility of noise on a television receiver occurs at a C/N ratio of approximately 47 dB. Acceptable picture quality can be achieved with a C/N of 43 to 45 dB, and this is the target range that the industry uses in designing systems, unless otherwise specified by the operator.

### *Carrier-to-third-order intermodulation ratio (C/IM3)*

Third-order intermodulation is the beating together of two or three signal carriers to produce a spurious carrier, due to the third-order distortion characteristics of the amplifier. The beating together of three carriers is commonly called "Triple Beat." In a 54-channel system, approximately 1000 spurious signals (triple beats) will "stack" on the center channel. These beats are functions of all 54 channels and are randomly varying relative to each other, which presents itself as a random-type noise to the TV receiver.

The threshold of perceptibility of C/IM3 for 54 unmodulated carriers is approximately 53-dB RMS. Most systems are designed for a specification of 48-dB to 49-dB RMS because modulation on the carriers will give an 8-dB to 10-dB improvement due to the fact that the downward modulation reduces the total power, and hence the distortion.

### *Carrier-to-second-order intermodulation ratio (C/IM2)*

The C/IM2 is also an important parameter in a system. The effects of this distortion has been minimized by using push-pull circuits throughout all the amplifiers. The second-order intermodulation will "stack" the same as third-order intermodulation with the exception that there are considerably fewer spurious signals that would sum together on one channel. The carrier-to-second-order ratio is usually specified by a single beat frequency at a level of minus 60 dB.

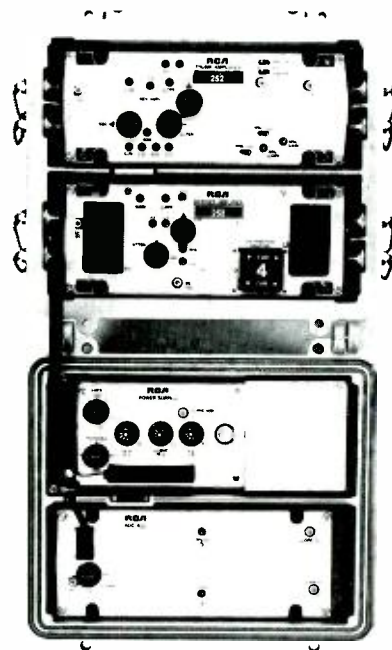


Fig. 3. Trunk bridger amplifier with cover open.

### *RCA distribution equipment*

RCA manufactures a complete line of CATV amplifiers. All units feature bi-directional operation and use push-pull hybrid-amplifier modules. Equipment is available for dual-cable as well as single-cable operation. The current product line has a bandwidth out to 300 MHz which will carry 36 channels in the forward direction on a single cable. We are currently developing 400-MHz amplifiers that will increase the capacity to up to 54 channels.

### *Subscriber devices*

After the many channels of programming are delivered to the subscriber's home, additional equipment is normally required to allow the subscriber to receive and decode (in the case of scrambled pay TV) the signals which are not always directly compatible with his TV set due to the frequency assignment or scrambling for security purposes.

### *Frequency converters*

The most widely used subscriber device is the frequency converter which is required to link a conventional TV receiver to the fifty or more CATV channels that are now becoming available on most cable systems. Conventional TV receivers can access only

channels 2 through 13 out of the available CATV spectrum. Standard TV channels 14 through 83 are in the UHF band which is well above the capability of CATV distribution equipment. Although some of the spectrum is allocated for other forms of communications, it can be "re-used" in the cable environment due to the high level of shielding provided. Only the aeronautical navigation band (108 to 118 MHz) is typically not available for cable use; however, even this band is sometimes used where compatibility can be provided.

Presently the RCA converter product line consists of the SCMC series 36-channel converter and the SCC block converter. The 36-channel converter is available as a single piece "set-top" unit or as a two-piece, cord-remote-controlled version. When using a multichannel converter, the TV receiver is fixed-tuned to the output channel of the converter which is available for channels 2, 3 or 4 as factory options. With this system, all channel selections are made by means of the converter selector control. For systems which use a block-converter approach, the channel-selection function is retained by the TV receiver. A group of three contiguous "mid-band" CATV channels are down-converted to the frequencies of standard channels 2 through 4, thereby providing access to extra channels by a conventional receiver. Normal reception of standard channels is furnished by a bypass switch.

### Decoders

It is increasingly important to supply program access to various groups of subscribers on a limited or controlled basis. Selected viewers require different combinations of services. Three major decoder devices that satisfy this need for selective reception of premium services are: traps, descramblers and addressable devices.

The simplest system uses trap devices. Selective reception is implemented by the insertion of a notch filter in series with the subscriber's service drop cable, tuned to the channel carrier of a premium service he is not authorized to receive. This approach is feasible in systems having a higher proportion of subscribers who desire the full premium service, thereby minimizing the number of traps required. However, it proves to be costly to change or add services.

A second class of selective reception devices uses scrambling of the video and/or audio. Encoders for these systems

take four basic forms: jamming, sync suppression, carrier control, or video-encryptographic systems. Decoding results from an inverse process.

Jamming techniques use a narrow-band masking modulation on a special carrier within the desired bandpass. The inverse process requires a simple yet exacting notch-filter design in order to provide a premium quality restored channel. On the other hand, a simple commercial or home-made trap can be used by the unauthorized viewer to obtain an acceptable quality level even though much of the high-frequency information has been lost. Jamming systems have a number of defects which limit the cost-effectiveness in multichannel applications. The traps adversely affect adjacent channels. High-frequency channels lose significant information due to difficulty of making narrow enough trap designs. Cost of premium service is a linear function of the number of premium channels. The jamming signals contribute to excessive intermodulation products in distribution equipment.

Encryptographic scrambling involves operating on the base-band video in some fashion, usually on a coded time basis. For example, video may be periodically inverted at coded rates. Line and frame storage can be used to construct out-of-sequence video. Generally excellent scrambling results, but high-quality reconstruction, is presently too costly for the CATV market.

Carrier-control encoding involves suppression of the video carrier. Often the carrier is recombined at some phase between 90° and 180°. These systems scramble better than the sync-suppression methods, but require very accurate and noise-free, phase-lock-loop circuitry to regenerate the decoding carrier.

Audio scrambling usually takes the form of "hidden audio" by means of carrier control. One technique transposes the aural carrier to band end, thereby changing the intercarrier frequency separation to inhibit audio detection by standard receivers. Other methods use various multiplexing schemes to provide "barker" audio as well as "hidden" program audio. Generally audio scrambling has not been considered cost-effective. However, the rising popularity of special-event programming such as sports, live shows, etc., which have high-value audio content could change the economics in the near future.

Of the various encoding approaches, the sync-suppression methods offer the best compromise between effectiveness of the

scrambling and quality of reconstruction. These systems modulate the video-RF envelope with a periodic wave which suppresses the sync periods so that a standard sync separator cannot function properly due to confusion with active video. The frequency of the scrambling waveform is a multiple of horizontal sync and is phase-locked to sync. The two scrambling signal waveforms that are widely being used are the sinewave and composite blanking signals. In practice it has been found that the composite blanking system gives superior noise performance because a noise-free clipped waveform can be used during the decoding modulation process. All noise transitions occur during blanking and, therefore, are not visible in the decoded picture. The sinewave decoding signal changes in amplitude throughout the entire line, making any associated noise visible since the signal cannot be clipped or simply filtered.

Addressable systems are a major developing class of selective reception devices that use communication channels to selectively enable various subscriber devices ranging from taps to converter/decoders. Basically, addressability is a control concept but it does not eliminate the need for companion security techniques to prevent the use of unauthorized converters. As such, the idea is gaining wide acceptance as an economical method of controlling program authorization and disconnect functions. Two-way addressability has not yet proved to be economically viable; but the obvious benefits of pay-per-view, purchasing, polling, banking and a great variety of other interactive services have generated great interest. It appears to be just a matter of time before interest becomes demand.

The first RCA encoder/decoder product entry was recently announced at the NCTA convention in May, 1980. This equipment consists of the model ESS10 encoder and the series SSO decoder (Fig. 4). The system uses sync-suppression scrambling of the composite-blanking variety. Encoding is accomplished by means of modulating the video RF envelope with a composite blanking signal such that the envelope is reduced by 6 dB during all horizontal and vertical blanking intervals, thereby reducing the sync amplitude below black-level by approximately 3.5 dB. Due to the very simple modulation function required, scrambling is achieved by means of an electronically-controlled attenuator having two switchable states under control of the blanking waveform. Descrambling is im-

plemented by means of a similar switchable attenuator in the decoder, which is under synchronous control of an inverse blanking function to operate on the encoded RF signal and return it to a decoded or constant attenuation condition. The synchronizing information is communicated to the decoder by an amplitude-modulated signal which is contained in one of three separate pilot channels. The SSO decoder can decode at least three premium channels. However, each pilot signal may decode any number of video signals if they have been synchronized by means of a special headend time-base corrector. Therefore, each pilot channel represents decoder timing information for one or more channels of premium programming known as "levels" of service. Additional programming flexibility can also be achieved by using all possible combinations of three levels to provide seven "tiers" of premium programming.

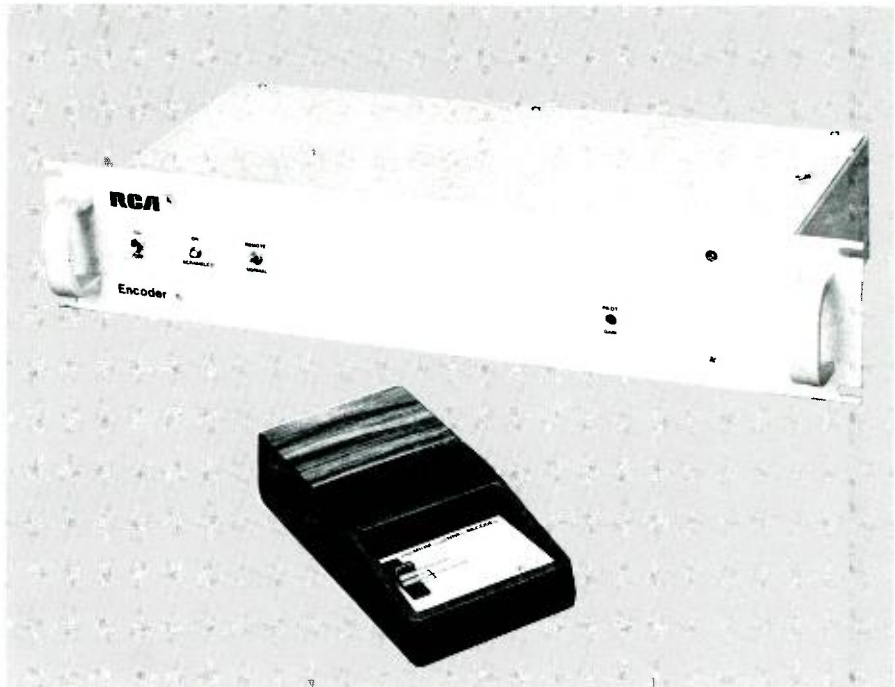


Fig. 4. Pay-TV encoder and decoder.

### Converter/decoders

Presently under development is a combination converter and decoder in one package. Placing the decoder at the converter output avoids any significant noise figure degradation due to the decoding process. The single-unit package also eliminates the awkward and unsightly two-box arrangement and provides a simpler operating one-control system.

### Future trends in CATV technology

Cable TV systems will be increasing their bandwidth capability in the future and making more efficient use of the operating bandwidth now available. Automatic monitoring and control of CATV equipment performance will be used to improve system reliability and reduce maintenance costs. Subscriber terminals will provide additional services and will be controllable from the headend.

### Increased bandwidth

Competitive franchising activity for new CATV systems has resulted in operating companies committing to provide additional channels over and above the typical 36-channel 300-MHz system. Cable-system technology is responding to this requirement with wider bandwidth components (amplifiers, passives, cable)

and headend equipment to generate new channels to use the additional system bandwidth. The new RCA Model-452 trunk/bringer amplifier will be available in 1981 and will have a bandwidth of 400-MHz.

The cost increase of a 400-MHz system relative to a 300-MHz system is in the order of 20 percent, however, the increase in the number of available channels is almost 50 percent. This indicates the increased bandwidth is a cost-effective way to increase channel capacity. Many older cable systems will take advantage of the increased bandwidth technology when existing franchises expire and system rebuilding is required.

### More efficient use of spectrum

Today many cable systems generate one or more alphanumeric signal channels. The data-rate relative to the bandwidth used is very low for this method of data transmission which provides inefficient use of the cable spectrum. Future technology will allow alphanumeric data signals to be transmitted during the vertical interval of normal TV channels rather than consuming additional channels. This type of data transmission will probably use a standard teletext signal format which requires a decoder at the cable subscribers terminal or a decoder as part of the home TV receiver.

RCA Cablevision has conducted ex-

tensive testing of its headend and distribution equipment to verify its performance capability relative to this new teletext signal. An area of performance which is very important to the wideband teletext signal is phase response. Poor phase response in any portion of the system can cause excessive transients and result in data errors. RCA cable products were tested individually and as a system for transient response, and the results confirmed that RCA cable equipment is ready for teletext signals when they become available.

The cable operator will also be able to devote a complete TV channel assignment to data transmission if desired. All of the horizontal lines normally used for picture transmission could be used for data rather than one or two lines in the vertical interval as is normal for conventional teletext. This would provide efficient use of the channel spectrum.

A portion of the CATV spectrum which is relatively untapped is the return signal path. This spectrum will gain usage as technology provides cost-compatible two-way cable services.

### Automated monitoring and control

Digital technology will gain more usage in headend and distribution equipment to perform monitor and control functions. Use of these functions will aid in maintenance and improve reliability of cable systems.

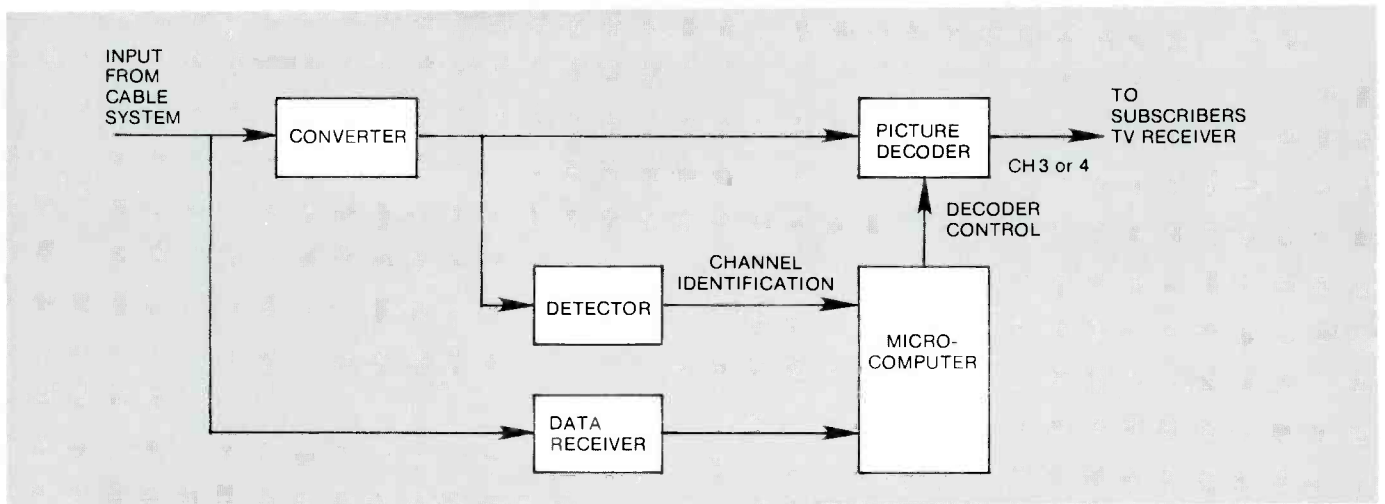


Fig. 5. Subscriber terminal.

New amplifiers will have the ability to monitor performance parameters and to remotely switch feeder-cable return paths. New headend products will have microcomputers to monitor and analyze equipment functions. System control from a central location will become possible.

### Subscriber terminals

Terminals will be available in the near future with more features. First of all, they will have increased channel coverage to be compatible with the increased cable system bandwidth. Synthesized tuning will be the norm. Each terminal will be addressable

and controlled from the headend. This will allow cable operators remote control of such things as tier level of service and subscriber disconnect. Premium channel decoding will be an integral part of this terminal. Figure 5 shows a converter with these near-term features.

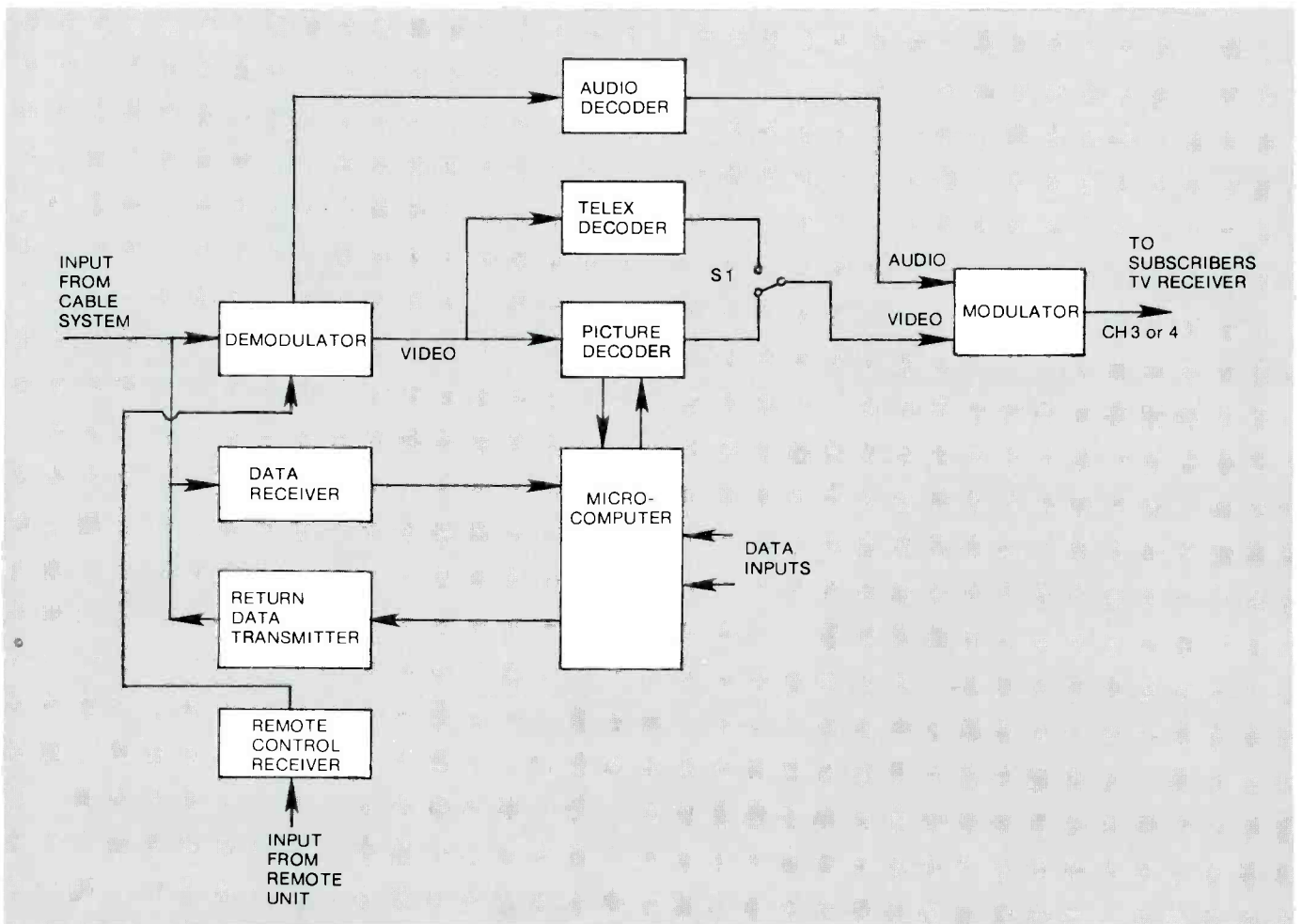


Fig. 6. Future subscriber terminal.



Farther downstream another generation of subscriber terminals will be available with additional features and capability over and above those previously described. These units will demodulate the cable signal to baseband audio and video which allows a more secure scrambling system to be used on premium programming. It also allows subscriber remote audio level control. Teletext data signals can also be processed from the baseband video. A return data transmission feature will allow two-way interactive services. This terminal will be upgradeable to provide the different features with plug-in modules. Figure 6 shows this type of terminal.

### Fiber optics

Use of fiber optics will be an alternative to conventional coaxial cable for construction of CATV systems. Some experimental point-to-point transportation trunking fiber-optics systems have been built but the cost at present is higher than using conventional coaxial cable.

Present fiber-optics systems suffer from the fact that the light signal is converted to a VHF signal for amplification and then converted back to light for transportation down the fiber. This means the signal is degraded by the transducers in addition to the VHF amplifiers. This additional

degradation reduces the spacing between repeaters to the point where it is not cost competitive with coaxial-cable systems. The light signal must again be converted to VHF if a conventional TV receiver is connected to the system. Fiber optics will continue to be used for experimental point-to-point signal transportation but will not gain widespread usage in CATV distribution systems until it becomes more cost-effective.



Left to right: **Bob Hamell**, Manager, Headend Equipment; **Bert Arnold**, Manager, Distribution Equipment; **John Ovnick**, Chief Engineer; **Karl Angel**, Manager, Terminal Equipment; and **Bob Schoenbeck**, Staff Technical Advisor.

**John Ovnick** is the Chief Engineer at RCA Cablevision Systems Division. He joined RCA in 1971 and has held the current position since 1972. Early in his career with RCA, he was the project engineer for an interactive home terminal system that provided pay TV, home security, opinion polling, in-home shopping and channel monitoring. Since that time, he has been responsible for new product development for Cablevision.

Contact him at:  
**RCA Cablevision Systems**  
**Van Nuys, Calif.**  
**TACNET: 534-3011**

**Bob Hamell** is Manager of CATV headend products, RCA Cablevision Systems. His present responsibilities include managing the development of new headend products. His background includes telemetry and

communications equipment design and more than 10 years with RCA in CATV headend products design.

Contact him at:  
**RCA Cablevision Systems**  
**Van Nuys, Calif.**  
**TACNET: 534-3958**

**Bert Arnold**, Manager Distribution Systems, worked as a broadcast engineer for KERO-TV in Bakersfield, California, from 1961 to 1963. CATV experience includes three years with Anaconda Electronics and over ten years with RCA, CVS division. His present responsibilities include management of development of CATV distribution equipment and technical support for Marketing. He has written and presented papers in the 1969, 1973, 1975 and 1978 NCTA conventions, as well as various regional con-

ventions, and the 1977 and 1979 International TV Symposium in Montreux, Switzerland. Bert is a Senior Member of SCTE.

Contact him at:  
**RCA Cablevision Systems**  
**Van Nuys, Calif.**  
**TACNET: 534-3957**

**Karl Angel**, Manager, Terminal Equipment, joined RCA in 1955. He worked in the Receiving Tube Application Lab at Harrison, New Jersey, and was transferred to the David Sarnoff Research Center in Princeton, New Jersey in 1961, where he was assigned to an advanced development group working in mobile communications, marine radio and audio-visual products. In 1963, Mr. Angel was appointed group leader.

In 1969, he was appointed manager of a video products design group responsible for the development of a variety of small-studio video equipment. After ten years with other companies, Mr. Angel rejoined RCA in 1974. He has been responsible for product development of set-top converters, encoders, decoders and addressable devices.

Contact him at:  
**RCA Cablevision Systems**  
**Van Nuys, Calif.**  
**TACNET: 534-3959**

**Bob Schoenbeck**, Staff Technical Advisor, RCA Cablevision Systems, joined RCA after working for Collins Radio Company, General Electric and Electronic Specialty Company where he was engaged in the design of VHF and UHF communication equipment. Since 1971, he has held the position of Staff Technical Advisor, providing technical support to Engineering and Marketing. Headend Systems Design has been a recent area of responsibility. Present efforts are directed toward advanced product development.

Contact him at:  
**RCA Cablevision Systems**  
**Van Nuys, Calif.**  
**TACNET: 534-3956**

# High-accuracy ranging over voice radios

*Digital technology and LSI implementation transform a conventional military survival walkie-talkie into a high-accuracy ranging system that helps locate downed pilots.*

---

**Abstract:** *This paper describes the operational requirements and scenario for a military downed-aircrew rescue. The basic technique involved in a half-duplex ranging system and the specific techniques developed to meet the operational requirements and to transform a voice radio into a high-accuracy ranging radio are then discussed in some detail. The problems discussed are efficient modulations in an AM radio, delay variation control, rapid acquisition using a narrow bandwidth radio, memory requirements for half-duplex operation and digital design for miniaturization.*

---

Military aviators have long carried survival equipment. Unfortunately, this survival equipment has been only minimally effective in aiding search-and-rescue efforts, especially in the typical wartime scenario. Because of their investment in a trained aircrew, and because of the basic risk to the life of the survivor as well as the potential rescuer, the U.S. Air Force has sponsored a program to apply new technology and techniques to this important problem.

Consider a typical search-and-rescue (SAR) mission pictured in Fig. 1. Today, military airmen carry small, light and simple survival radios in their flight vests, along with their parachute. The radio allows a downed airman to speak with a crew in a rescue aircraft and the airman can set it to emit automatically a continuously sweeping tone modulated radio signal (continuous beacon transmit). The beacon signal, immediately recognizable as a survivor's radio transmission, allows SAR crews to use homing or direction-finding



**Fig. 1. Search and rescue scenario.** Initial contact with the survivor may be made by a standoff fixed-wing aircraft, which forwards location data to a local search-and-rescue helicopter. The survivor may not be able to play an active role in his own rescue if injured or unconscious.

equipment in their aircraft to locate the survivor by "flying the needle." But a hostile military operation poses problems. First, while on a homing course to the survivor, the SAR aircraft may fly over enemy artillery, and since the SAR pilot does not know the distance to the survivor, he cannot plan an avoidance route. Second, the SAR pilot cannot be sure whether the survival radio belongs to friend or foe. "Spoofers" use captured survival radios to call in and then destroy SAR aircraft. Currently, SAR crews try to talk directly to the survivor for authentica-

tion, but if the radio is in the continuous beacon transmit mode, the survivor will not hear a voice transmission. When the survival radio is in continuous transmit the battery life is severely shortened, but if it is not transmitting, the SAR pilot cannot locate it.

The Survival Avionics System being developed for the Air Force overcomes these problems with a ranging and identification subsystem. It also has a high-accuracy, interferometer, angle-measurement subsystem and extensive operator assistance as well as coordinate

Reprint RE-26-3-12  
Final manuscript received Sept. 3, 1980.

stabilization and conversion from the control and navigation computer subsystem.

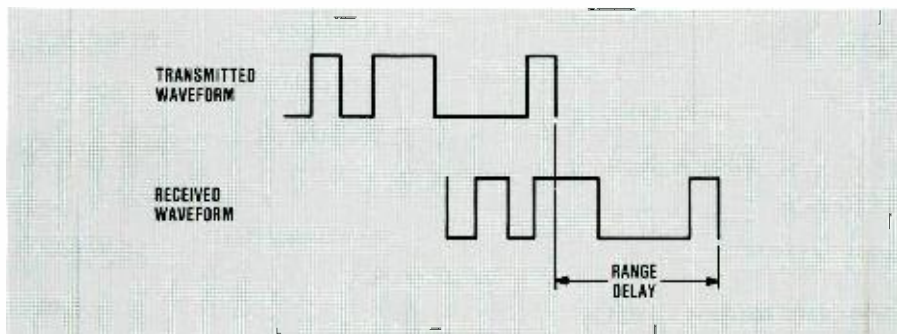
## The ranging system

RCA's Government Communications Systems (GCS) has developed a high-accuracy ranging system compatible with hand-held survival radios like those now used. The system capitalizes on advanced digital techniques and monolithic LSI implementation. A small digital transponder module added to the survival radio operates in conjunction with a ranging interrogator in the SAR aircraft. The only change to the radio itself is the addition of a double-balanced mixer in the RF front end of the radio. How was the survival radio transformed into a high-accuracy, digital, ranging transponder?

First of all, system studies showing tradeoffs between user needs, technology availability and cost determined the ranging system requirements. The system is restricted to the military aircraft communications band of 225 to 400 MHz. The ranging system had to function to 100 nautical miles, the operating range for communications radios in this band. A nautical mile is 6076.115 feet or 1852 meters. Half-duplex operation (no simultaneous transmit and receive) keeps the survival radio simple. The radio's accuracy requirements are based on the need for initial acquisition of the survivor and for final steering information at pickup. A two-percent accuracy requirement allows the rescuers to send infrequent interrogation signals while at long range, thus minimizing transmission time. At close range, approaching the pickup site, the system's accuracy actually improves in absolute terms. A requirement of seven percent at 200 feet provides less than a 14-foot error. This accuracy actually means that crewmen could lower a rope ladder to within the reach of a survivor, without seeing him.

## The approach

Range measurement using continuous RF signals depends on our ability to measure the round-trip signal-propagation time between two radios at different locations. If the radio at the far location retransmits a received signal with no delay, the propagation delay time can be measured, at the near location, from the phase difference between the signal transmitted and the signal received. Figure 2 shows a pseudo-



**Fig. 2. Range measurement with pseudo-random code.** The range is directly proportional to the phase shift or delay between the transmitted and received waveforms, whether that waveform is a tone or a pseudo-random code.

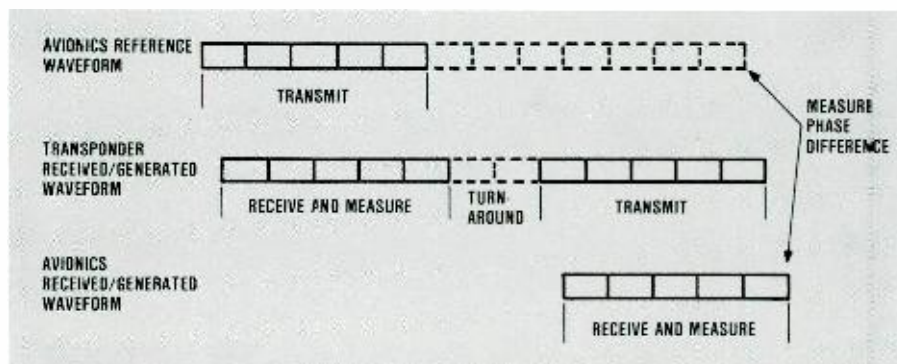
random code as it might be transmitted and received at the near location. The phase delay, measured in nanoseconds, can be converted to a range distance by the propagation-velocity constant for RF signals (.4917 feet/nanosecond). The one-way range is half of the round-trip range.

For a half-duplex ranging system, the radio at the far location cannot retransmit its received waveform with zero delay because it cannot receive and transmit simultaneously. Therefore, the system must operate in a time-sequential interrogate/transpond mode. The transponder becomes important because the transponder must very accurately measure the frequency and phase of the received waveform, remember that measurement while the radio switches from receive to transmit, and finally retransmit the waveform back to the interrogator. The interrogator, having also remembered what it transmitted (internal reference), now measures the phase difference between that reference waveform and the waveform received from the transponder. Figure 3 depicts the timing of this operation.

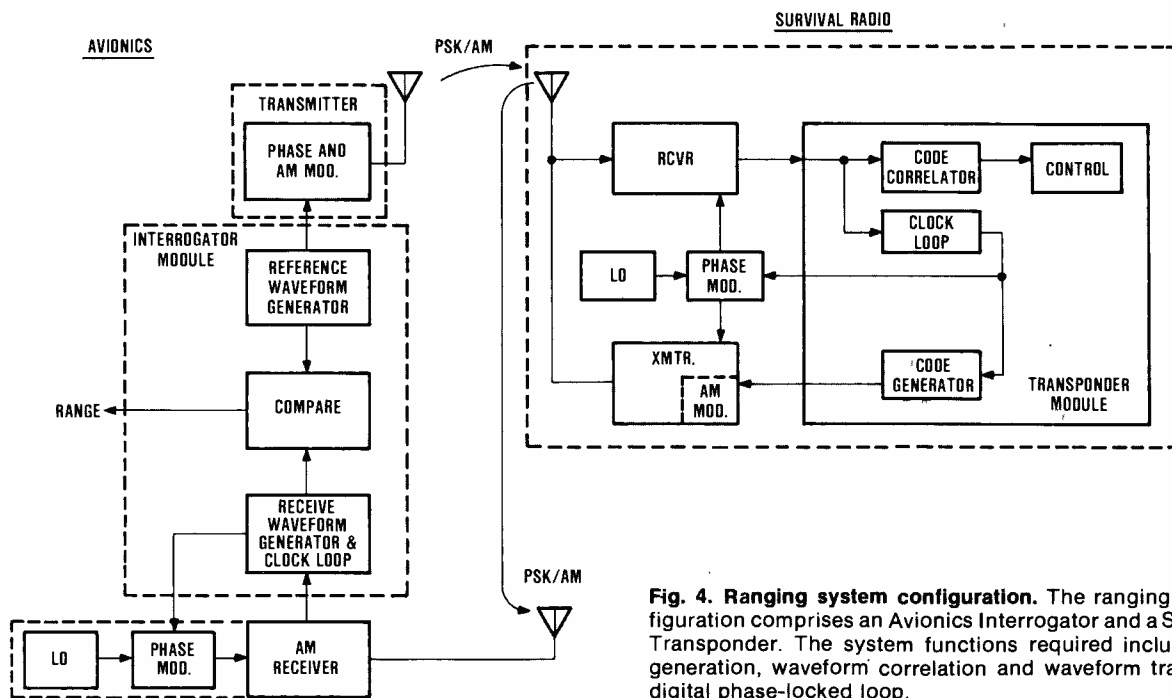
The critical nature of the transponder functions can be appreciated by a few simple relationships: range error equals the

time error multiplied by the propagation velocity and then divided by two. The division by two arises because the actual distance is half the round-trip distance. The time error can be introduced in two ways in the transponder. First, simple phase error in the measurement of the waveform converts directly to time error because time error equals the phase error (radians) divided by the fine tone frequency (radians/second). The second introduction of time error results from an error in the measurement of the frequency of the fine tone at the transponder. The frequency error actually appears as an accumulating phase error over the transponder memory period, that is, time error equals the frequency error multiplied by the memory time, all divided by the fine tone frequency. The frequency error tends to be the primary contributor to range error. To meet the system requirement of 14-foot maximum error, the frequency resolution must be better than one part in  $10^7$  for a 250-millisecond memory interval.

Figure 4 is a block diagram of the complete ranging system. The avionics equipment (left side of the diagram) comprises a transmitter with amplitude and biphasic modulation, an AM receiver with a



**Fig. 3. Half-duplex ranging system timing.** In the half-duplex ranging system, the radios cannot transmit and receive at the same time. Therefore, the ranging waveform frequency and phase must be precisely measured and controlled at the transponder for accurate replication during the transponder transmit period.



**Fig. 4. Ranging system configuration.** The ranging system configuration comprises an Avionics Interrogator and a Survival Radio Transponder. The system functions required include waveform generation, waveform correlation and waveform tracking with a digital phase-locked loop.

biphase modulator on the receiver local oscillator output and the ranging interrogator module. The survival radio (right side of the diagram) comprises an AM receiver/transmitter also with a biphase modulator on the local oscillator output and the transponder module.

### System operation

The reference waveform generator in the ranging interrogator modulates the transmitter with the ranging waveforms. The survival radio receives this signal which activates the code correlator and clock-tracking loop so that the waveform can be measured. After a fixed amount of time, the transponder control circuits begin the change from the receive mode to the

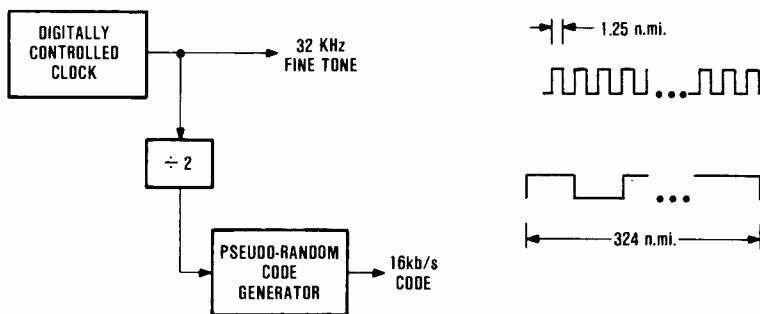
transmit mode and the radio sends the ranging waveform back to the avionics receiver. The receive waveform generator and clock loop lock up to the ranging waveform, and finally the comparator circuit measures the difference between the receive waveform generator and the reference waveform generator and reads out the range data.

The ranging waveforms for continuous-modulation systems (different from pulse systems) have conflicting requirements of fine granularity (small increments of distance able to be measured by high frequency waveforms) for accuracy and long repetition periods to resolve long range without ambiguity. The repetition period of interest has to be greater than the propagation time you are trying to

measure—the target must be inside a known range. Otherwise the distance estimate may be grossly wrong.

Some ranging systems use multiple tones sent sequentially to fulfill these requirements. More recently, the pseudo-random code has become popular because it fulfills them simultaneously. Figure 5 shows the waveform generator in this system. A fine tone is used in addition to the pseudo-random code. The frequencies of the waveforms have been selected to be consistent with the digital voice rates that can be accommodated in current military communications equipment. The pseudo-random code is 64-bits long, thus providing a repetition period of 4 milliseconds at the 16 kb/s clocking rate. The 4-millisecond period provides unambiguous range resolution to 324 nautical miles, more than enough for the 100-nautical-mile requirement.

The fine ranging tone in some ranging systems is chosen to be a very high frequency to provide fine range granularity. Ten-MHz fine tones are not unusual. This would provide a range granularity of 24.3 feet or 0.004 nautical miles. The fine tone chosen for the present system is 32 kHz for compatibility with the military voice radios and the crowded UHF spectrum. This frequency provides a granularity of 1.25 nautical miles or 7595 feet. Therefore, to meet the range accuracy requirement, this tone must be resolved by a factor of 1000 by the high accuracy digital tracking loop.



**Fig. 5. Ranging waveform generator and waveforms.** The ranging waveform combines a fine tone with a pseudo-random code. The fine tone provides accuracy by supplying many transitions for edge tracking. The pseudo-random code provides the equivalent of a coarse tone to resolve range ambiguities out to 324 nautical miles.

**Table I. Ranging system requirements.**

Operating range:	0 feet to 100 nautical miles
Accuracy:	2% between 2 and 100 nautical miles 7% between 200 feet and 2 nautical miles
Available radio equipment:	Military UHF (225-400 MHz) half-duplex voice radios
Transponder module physical requirements:	250 milliwatts (power) 2.0 cubic inches (volume) 1.7 ounces (weight)
Selective interrogation by identification codes	
Minimum transmission time for low detectability and low power drain	

To make the basic system concept work (block diagram, Fig. 4) we had to develop new techniques and apply new technologies. Based on the requirements of Table I, we faced five principal design problems.

- Efficient modulation is required to provide efficient use of the low transmitted power of a hand-held radio and to avoid interference, whether intentional (jamming) or unintentional (noise, etc.).
- Delay variation control with delay measurements to 28 nanoseconds are required to meet the accuracy requirement. The typical receiver has 50 microseconds of delay between its RF input and audio output.
- Narrowband limitations mean that the narrowband modulation needed for minimum spectrum use requires high resolution in the measurement device to meet the accuracy requirement.
- Half-duplex operation requires a highly accurate time memory in the transponder.
- Small-size and low-cost mandates digital LSI implementation that will also result in low cost for the expected high quantity purchase.

### Efficient modulation

The survival radio provides voice communications with amplitude modulation (AM). But, AM is the least efficient of the modulations commonly used today, because most of the power resides in the RF carrier wave rather than in the modulation sidebands. As a result, frequency and phase modulation are preferred. But the penalty is greater complexity in the modulation or demodulation circuitry. For example,

phase modulation gives the greatest benefits, but suffers from requiring an extremely complex demodulator, a doubler loop or a Costas loop, in comparison to the simple envelope detector for AM.

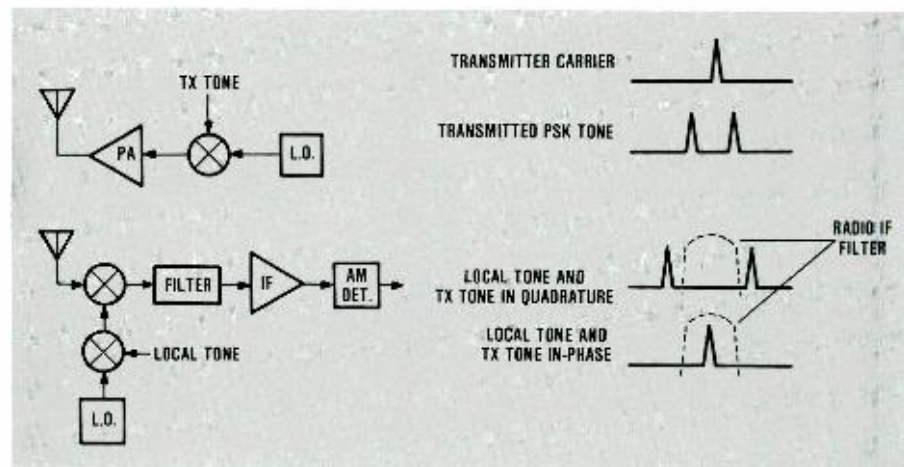
For the accurate measurement of a waveform with a tracking loop, a discrimination or correlation function is required. A simple correlation function can be generated using the reciprocal properties of biphasic Phase Shift Keyed (PSK) modulation with a normal AM voice radio. Figure 6 illustrates the technique. The transmitter carrier is biphasic-PSK modulated by the squarewave fine ranging tone—the carrier is shifted in phase between 0° and 180° by the ranging tone. This creates a suppressed carrier waveform with two major sidebands spaced from the suppressed carrier at a distance equal to the modulating frequency.

At the receiver, a similar modulation process is performed, using a local tone at

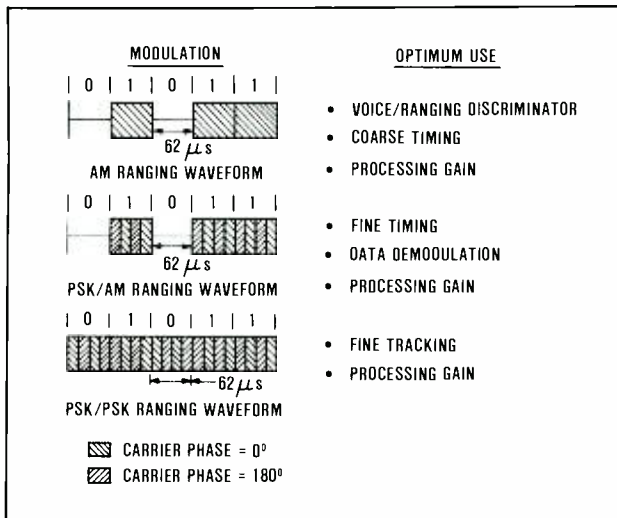
the same frequency. When the local tone and the transmitted tone are in-phase, the transmitted carrier is fully restored. When the local tone and the transmitted tone are in quadrature, the result is the equivalent of an RF carrier modulated at twice the frequency. As the phase between the two modulations is varied between quadrature and in-phase, the power is transferred linearly from the sidebands to the carrier. If the ranging tone frequency is chosen properly, then the sharp selectivity of the AM receiver IF amplifier will reject the sideband power and pass the carrier power. This, then, provides the desired correlation function at the AM detector (audio) output. Furthermore, the desired PSK modulation is used without requiring a coherent demodulator.

The correlation function of the fine tone is used to provide tracking of the fine ranging tone and, therefore, the fine granularity. The coarse granularity is provided by the pseudo-random code. This signal is used to amplitude modulate the transmitted signal and it is passed directly through the AM receiver to the audio output where it is processed in a baseband correlator. The bit rate for the pseudo-random code must be chosen to pass through the IF filter.

Graphic representations of these modulations are given in Fig. 7. The first diagram shows the basic amplitude modulation with the pseudo-random code. This waveform is used to discriminate between voice transmissions and ranging interrogations, since the PSK feedback in the receiver local oscillator must only be activated during processing of ranging signals to avoid garbling of voice transmissions. The second diagram shows



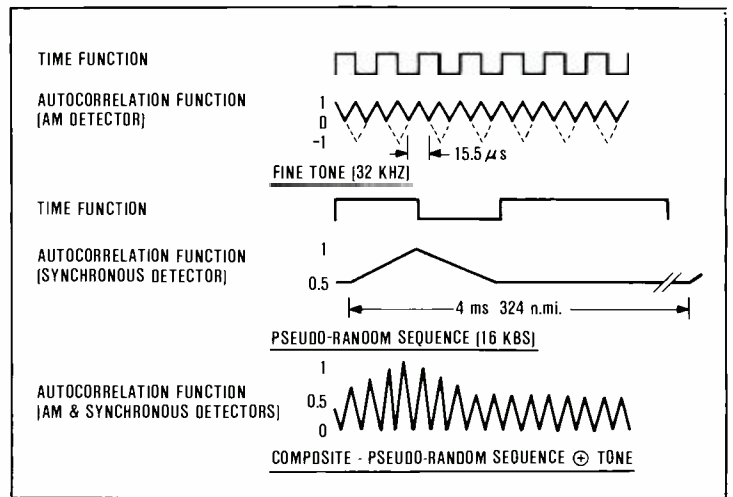
**Fig. 6. Spectrum correlation.** The reciprocal properties of bi-phase PSK modulation are used to provide a correlation function of the ranging waveform. As the phase relationship of TX tone and local tone shifts from quadrature to in-phase, the signal energy in the IF increases linearly.



**Fig. 7. Ranging modulations.** Different combinations of AM and PSK modulation are used with the fine-tone and pseudo-random code to provide solutions to different system requirements.

the PSK modulation combined with the AM modulation. This waveform is used for providing fine granularity timing and for the demodulation of data which can be carried in the pseudo-random code. If the pseudo-random code is inverted (complemented), the baseband correlator still produces a correlation peak, however, its sense (polarity) is inverted. This inversion of the correlation peak is used to send mark/space (binary) data. The third diagram shows all PSK modulation where the pseudo-random code and the fine tone have been combined by modulo-2 addition. This waveform provides the most precise range resolution and the maximum processing gain.

The correlation functions for these waveforms are shown in Fig. 8. The correlation function for a square wave is a triangular waveform. Because of the unipolar action of the AM detector (i.e., unable to discriminate between carrier phases), the triangular waveform folds over about zero. The correlation function of a pseudo-random code is zero everywhere except within one chip (one clock interval) of precise alignment. Within the one-chip interval, the function is again triangular. The baseband correlator (synchronous detector) also provides a unipolar output which raises the correlation function above ground. The composite correlation function, shown at the bottom of Fig. 8, shows the combination of the fine-tone and pseudo-random code correlation functions as they appear at the output of the baseband correlator. Precise range alignment occurs at the pinnacle of the largest peak.



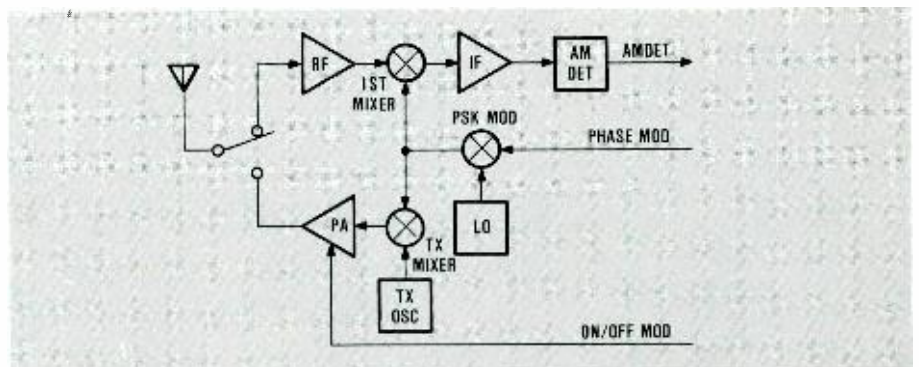
**Fig. 8. Correlation of PSK/AM ranging waveform.** The correlation function measures the degree of agreement between two waveforms as the waveforms are time-shifted through their full period. The correlation functions of the fine-tone and the pseudo-random code are multiplied together to provide the composite correlation function. The highest peak is accurately tracked to measure the ranging waveform.

## Delay variation control

Measurement of range to an accuracy of 14 feet requires resolution of all delays to better than 28 nanoseconds total. The typical voice radio receiver has about 50 microseconds of delay. The predominant contributors to this delay are the IF filter, which generally comprises an eight pole design with a bandwidth of 25 to 70 kHz, and the baseband circuits. Controlling this delay to 28 nanoseconds by specification over temperature, signal strength variation, component tolerances and from unit-to-unit is impossible. Active calibration of the system might be work if the receiver and transmitter could operate simultaneously; however, for the survival radio, this is impossible as well. However, if the tone-tracking loop could track to a discrimination function applied before the IF amplifier delay, the problem would be

greatly simplified. Delays in RF circuits are on the order of 200 nanoseconds because the bandwidths are much wider (3 to 10 MHz in the UHF band). Controlling these delays to within 10 percent is reasonable. The PSK modulation technique described under *efficient modulation* provides waveform correlation and feedback to the local oscillator output in the RF circuits.

Figure 9 shows the configuration of a typical amplitude modulation receiver/transmitter. The same local oscillator is used for both the receiver and transmitter. The local oscillator frequency is offset from the RF carrier frequency by the frequency of the IF. The TX oscillator is also at the IF frequency to restore that offset before transmission. When phase modulation is applied to the output of the local oscillator, that modulation is transferred to the RF signal, resulting in a feedback signal which tracks out the delay



**Fig. 9. AM receiver modified for ranging.** The AM receiver is easily modified for ranging by adding a PSK modulator to the local oscillator output. This provides waveform feedback ahead of the long time delays in the IF which would severely degrade range accuracy.

of the IF during receive operation. Therefore, the only uncalibrated delays are those of the receiver RF amplifier and first mixer, and those of the transmitter mixer and power amplifier. All of these are broadband circuits.

## Narrowband limitations

It was previously described that many megahertz of modulation bandwidth (>10-MHz) would be required if the granularity of the fine ranging tone were used to resolve the fine range. In the military UHF band, 175-MHz wide, frequency allocations of that width are unattainable. Normal analog voice channels occupy 25-kHz spacings and digital secure voice occupies 75-kHz spacings. The ranging modulation cannot be more than this. The use of a narrowband modulation, with a half period of 16.5 microseconds, requires precise resolution of the modulation transitions. This is provided by a high-accuracy digital, phase-locked tracking loop operating on the fine-tone correlation function previously described.

The fine-tone correlation function is converted into a phase-discriminator function, using the early/late tracking technique. Figure 10 shows one cycle of the triangular correlation function in an early and late time relationship. If the late waveform is subtracted from the early waveform, the third waveform results. This waveform provides a positive-error signal when the timing is early and a negative-error signal, when the timing is late. Precise timing is achieved exactly halfway between the early and late correlation peaks which is at the zero crossing of the E/L discriminator function.

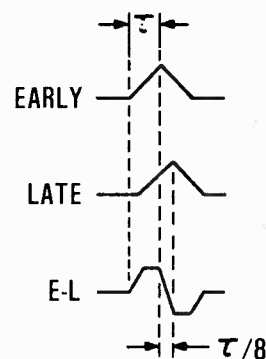
The implementation of a digital phase locked loop, using the early/late discriminator and the PSK feedback correlation technique, is illustrated in Fig. 11. A digital voltage-controlled oscillator (DVCO) drives the fine-tone waveform generator which has two outputs equally spaced from nominal timing. Control circuitry sequentially selects the early and late waveforms to be applied to the feedback PSK modulator. This feedback induces an amplitude modulation in the received ranging signal at the early/late switching rate in accordance with the PSK correlation function, as shown at the IF output. A switch routes the AM detector output into a sum and difference amplifier in synchronism with the selection of early and late timing. This signal is then averaged and integrated in the loop filter. For the accuracy re-

quired, a loop bandwidth of 3 Hz was implemented.

## Half-duplex operation

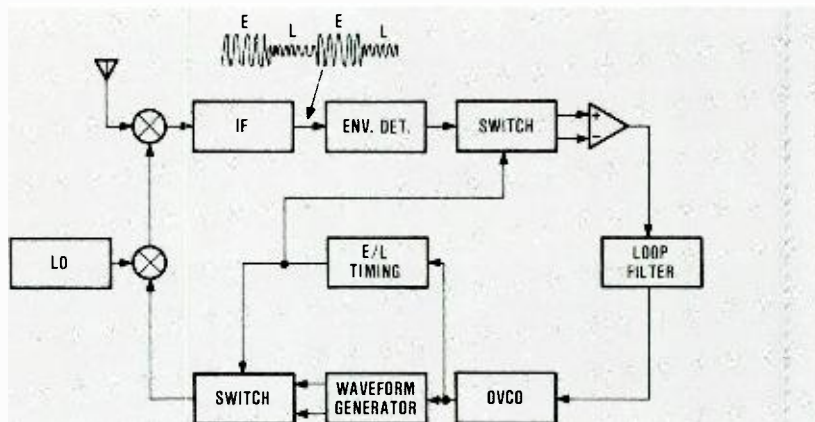
One of the most challenging requirements of the half-duplex ranging system is the accurate retention of the measured timing information, while the transponder switches from receive to transmit and sends its information back to the interrogator. This problem was one of the most serious shortcomings of previous systems. These systems have used analog VCOs in the phase-locked loop, and the frequency and phase relationship was controlled by an analog voltage. This voltage was stored in a sample-and-hold circuit, basically comprising a capacitor and a high-impedance switch. As can be imagined, the charge on the capacitor slowly leaks off causing frequency error and the resulting range error. The arithmetic synthesizer, digital VCO solves this problem.

The basic arithmetic synthesizer is shown in Fig. 12. A number  $X$  is con-

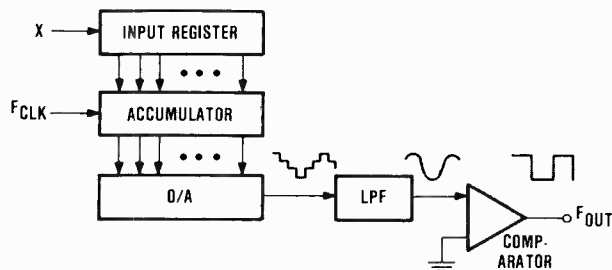


**Fig. 10. Early/late correlation function.** Advancing and delaying the system timing provides early and late correlation functions. When the early waveform is subtracted from the late waveform, a discriminator curve is generated which provides an error voltage of different polarities for early and late timing.

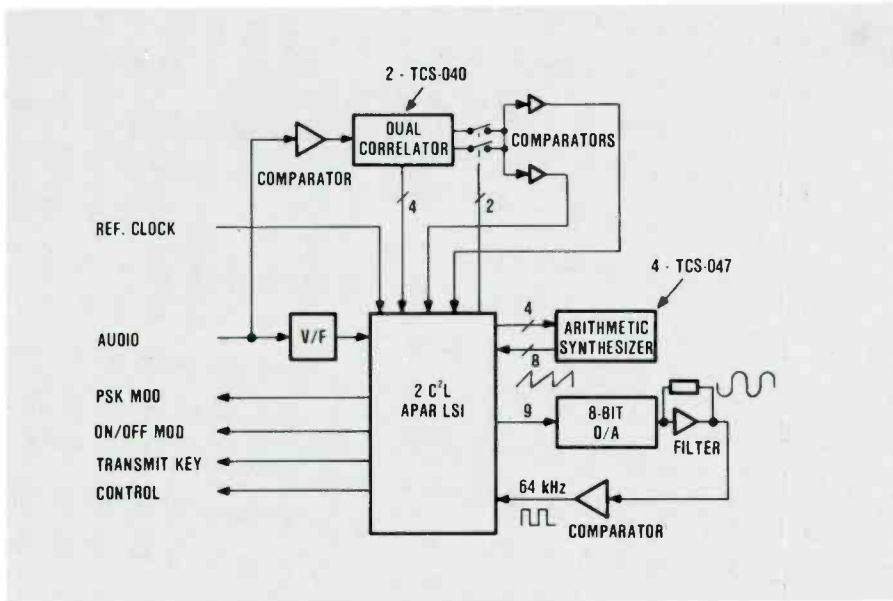
tinually added into the accumulator on each clock pulse. The instantaneous number in the accumulator is the phase of the output signal. The accumulator



**Fig. 11. Early/late range tracker.** This phase-locked loop uses the E-L error signal from Fig. 10 to force the nominal system timing, which is exactly halfway between the early and late waveforms generated locally, to equal the received waveform timing. The early and late waveforms are alternately selected for short periods and the error signal is integrated over many periods in the loop filter.



**Fig. 12. Basic digital VCO (arithmetic synthesizer).** A number  $X$  is added into the accumulator on each clock pulse. The DVCO output frequency is the rate of overflow of the accumulator. The cleanup circuits on the output signal reduce the jitter introduced by the time quantization.



**Fig. 13. Transponder block diagram.** An extremely high level of integration is achieved with four digital LSI circuit types. The A/D, D/A and few analog functions required four dual inline packaged ICs.

overflows to begin the next cycle of the signal. The frequency of the signal is determined by the value of  $X$  and the size of the accumulator. The output signal is recovered from the digital words by a  $D/A$  conversion which results in a triangular waveform, if the most significant bit is used as a sign bit. The  $D/A$  output is filtered and sliced to produce the VCO output.

The resolving power of the digital VCO can be demonstrated by a few basic

relationships. The output frequency is determined by:

$$f_o = \frac{(f_{CLK})X}{2^n}$$

where:  $f_{CLK}$  is the clock frequency of the accumulator

$X$  is the number in the input register

$n$  is the number of binary stages in the accumulator

The frequency granularity of the arithmetic synthesizer is determined by making  $X$  equal to one:

$$\Delta f_o = \frac{f_{CLK}}{2^n}$$

For the ranging system, a 30-stage accumulator was chosen to provide a frequency granularity of 1.12-millihertz or 1.7 parts in  $10^6$ , which will meet the resolution requirement of one part in  $10^7$  as calculated previously.

The phase granularity of the arithmetic synthesizer is equal to the size of the accumulator—one full cycle of the accumulator is  $2\pi$  radians. The minimum shift in phase is equal to a change of one in the input number for one accumulator clock period. This can be expressed as a time interval by:

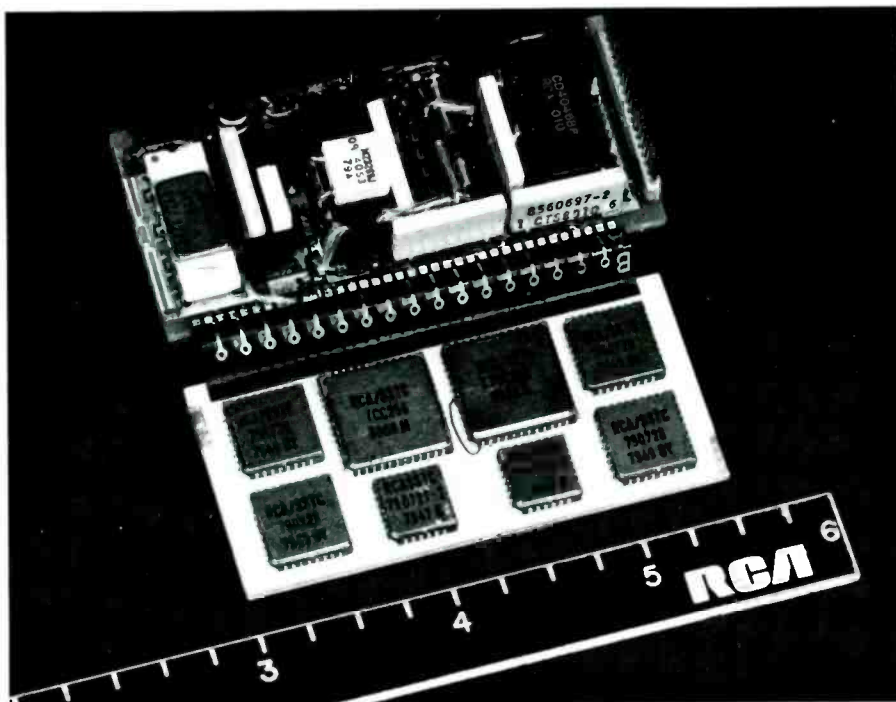
$$t = \frac{1}{f_o} \times \frac{1}{2^n}$$

The large size of the accumulator required to meet the frequency granularity provides a time granularity of  $1.5 \times 10^{-8}$  nanoseconds, which greatly exceeds the requirement of 28 nanoseconds for the total time granularity.

In locking to the ranging tone, the number  $X$  is calculated by the digital phase-locked loop to represent the frequency measured. Instantaneous changes in  $X$  can be used for one shot increments in phase to provide phase alignment. The final value of  $X$  is, therefore, analogous to the voltage contained in the analog sample and hold in the older systems. Because this number resides in a register, it represents a precise and perfect memory, limited only by the stability of the reference clock. Typical TCXO references provide better than one part in  $10^8$  stability over the 250-millisecond measurement interval.

### Small size, low cost

Implementation of the transponder in a highly integratable technology was required. The existing survival radios are 1.5 x 3 x 6 inches and no size increase for the added capabilities is possible due to operational considerations, survival vest-pocket-size and high-g acceleration of high-performance aircraft. The transponder was allocated a total of two cubic inches in the radio cross-section. Maximization of digital implementation was mandatory, so that custom monolithic LSI devices could be used.



**Fig. 14. Engineering model of the transponder.** The complete module occupies two cubic inches when folded in half for insertion into the handheld radio.



The functional partitioning of the transponder module is shown in Fig. 13. The digital implementation is maximized by immediately converting the radio AM detector output to a digital signal in a voltage-to-frequency (V/F) converter. All processing is then performed digitally except for the comparator circuits on the output of the correlator and the smoothing filter in the digital VCO.

The LSI complement incorporates two previously-developed device types for the dual-digital correlator and the arithmetic synthesizer. These devices are in SOS/CMOS technology. The balance of the transponder circuitry is divided into two new custom designs produced by the "Standard Cell" APAR (Automatic Placement and Routing) technique at the Solid State Technology Center in Somerville, New Jersey. These devices were implemented in C<sup>2</sup>L bulk CMOS technology. The first device contains the phase-locked loop control and processing circuitry, and the second device provides overall transponder timing and control and data processing.

The first model of the transponder is illustrated in the photograph of Fig. 14. The LSI have been packaged in leadless hermetic-chip carrier packages and are mounted on a ceramic substrate with fired-film interconnections and solder pads. The ceramic board is interconnected to a

multilayer-printed circuit board by a flexible printed circuit strip. The printed circuit board contains the V/F, D/A, analog filter and comparator devices. (The extraneous components overcome some development problems). The module is completed by folding the two boards together and attaching end brackets. The complete module has a volume of 2 cubic inches, weighs 1.5 ounces and is powered by 110 milliwatts.

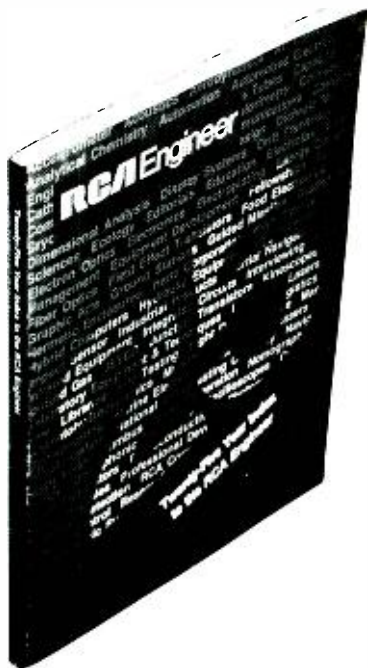
## Acknowledgment

The original conceptual work and system design was provided by Edward Nossen, Staff Engineer, Systems Engineering, GCS, Camden. This design represents the culmination of many years work in this area, including the successful Apollo ranging system, used for rendezvous maneuvers for the Lunar and Command Modules and the Apollo-Soyuz mission. The system realization, circuit implementation, and LSI design were performed by Robert Lisowski, Unit Manager Engineering Staff, Albert Crowley, Senior Member Engineering Staff, and Denis Claveloux, Member Engineering Staff, Communications Equipment Engineering, GCS, Camden. The author gratefully acknowledges their contributions to the success of this program.



**Roy H. Brader**, Unit Manager, Communications Equipment Engineering, joined the Advanced Technology Section of GCS in 1967 and specialized in advanced receiver design. He has worked in all areas of receiver design and has converted many of his designs to thick-film hybrid or monolithic implementation. Mr. Brader participated in the URC-78 Advanced Development Program with responsibility for the receiver design, complete R/T integration and test. In addition to his recent responsibilities on the Survival Avionics System program, he has worked in digital and microprocessor signal processing techniques for an M-ary Modem and two spread spectrum AJ systems for data and voice.

Contact him at:  
**Government Communications Systems  
 Camden, N.J.  
 TACNET: 222-3830**



### New Publication from the *RCA Engineer*

According to the RCA Engineering Information Survey conducted in 1977, the *RCA Engineer* is the second most important source of technical information about RCA, (the most important information source being the engineer's associates). The back issues of the *Engineer* — 150 of them — provide a record of RCA's progress in invention, development, and manufacturing. To make this wealth of technical information accessible to the engineers, a *25-Year Index* to the *RCA Engineer* has been published.

The *Index* can help you find specific information that is needed in your work. Or the *Index* might provide a vital contact in another RCA business who has related experience and who would be willing to consult with you. The *Index* gives you the opportunity to profit from RCA's technical heritage — to reuse knowledge, to build on past accomplishments.

The *25-Year Index to RCA Engineer* is available in all RCA Libraries. Recipients of the *RCA Engineer* can obtain their personal copies by writing to:

*RCA Engineer*  
 Building 204-2  
 Cherry Hill, NJ 08358

---

# Patents

---

## Astro-Electronics

Cutsogeorge, G.A.  
**Stabilization of monolithic integrated circuit output levels**—4224536

## Commercial Communications Systems

Bendell, S.L.  
**Focusing system for color TV camera**—4223253

Breithaupt, D.W.  
**Push-pull amplifier**—4218638

Breithaupt, D.W.  
**Horizontal synchronizing system**—4222074

Dischert, R.A.|Libbey, R.L.  
**Black level control system for a color television camera**—4218699

Easter, F.C.  
**Astable multivibrator circuit**—4216441

Foldes, P.  
**Rotatable polarization duplexer**—4222017

Gurley, T.M.  
**Television picture compressor**—4209227

Miller, A.M.|Richardson, H.J.  
**Intermittent prime film mover using multi-toothed wheel drive**—4215921

## Consumer Electronics

Balaban, A.R.|Steckler, S.A.  
**Sample-hold phase detector**—4216396

Bingham, J.P.|Lagoni, W.A.  
**Image detail improvement in a vertical detail enhancement system**—4223340

Craft, J.  
**AFT circuit**—4220974

Harford, J.R.  
**Modular printed circuit board**—4216523

Harford, J.R.  
**Keyed AGC circuit**—4218708

Lagoni, W.A.|Fuhrer, J.S.  
**Video image vertical detail restoration and enhancement**—4223339

## Government Communications Systems

Hannan, W.J.|Woll, H.J.  
**Patching tape for diffractive subtractive filter viewgraphs**—4221465

Nossen, E.J.|Haber, C.H.  
**Signal correlation means**—4224679

Schwartz, H.M.  
**Magnetic transducer head core**—4217613

## Laboratories

Barkow, W.H.|Shisler, R.W.  
**Convergence adjustment arrangement using magnetic tabs with differential motion**—4218667

Bart, T.E.|Mills, R.A.  
**TV graphics and mixing control**—4218698

Bell, A.E.  
**Optical anti-reflective information record**—4216501

Beil, A.E.|Bartolini, R.A.  
**Sensitivity information record**—4222071

Bloom, A.|Bartolini, R.A.  
**Ablatable medium for optical recording**—4218689

Bloom, A.|Burke, W.J.|Ross, D.L.  
**Optical recording medium**—4219826

Carlson, D.E.  
**Compensated amorphous silicon solar cell**—4217148

Carnes, J.E.|Dawson, R.H.|Kosonocky, W.F.  
**Comb filter employing a charge transfer device with plural mutually proportioned signal charge inputs**—4217605

Catanese, C.A.|Cosentino, L.S.  
**Isolation busbar for a flat panel display device**—4217519

Denhollander, W.  
**Raster distortion correction circuit**—4220898

Fox, E.C.  
**Peak detector circuit**—4216502

Haferl, P.E.  
**Deflection circuit with retrace control**—4223251

Ipri, A.C.  
**Fabrication of an integrated injection logic**

**device incorporating an MOS/Bipolar current injector**—4217688

Ipri, A.C.  
**Short channel MOS devices and the method of manufacturing same**—4225875

Johnson, H.C.  
**Scanning radar**—4219814

Kawamoto, H.|Allen, Jr., E.L.  
**Resistivity measurement system**—4220915

Levine, P.A.  
**Reduction of sparkle noise and mottling in CCD imagers**—4223234

Lusch, J.  
**Tuning position display system**—4222120

Martinelli, R.U.  
**Semiconductor device having integrated diode**—4225874

Mezrich, R.S.  
**Apparatus for dividing an arbitrary waveform into equal-amplitude steps**—4222008

Okuno, Y.  
**FM defect compensation apparatus**—4221930

Pankove, J.I.  
**Method and structure for passivating a semiconductor device**—4224084

Pritchard, D.H.|Sepp, W.E.|Lagoni, W.A.  
**Frequency multiplier for use with CCD comb filter**—4224638

Rast, R.M.  
**Hangup corrector useful in locked loop tuning system**—4218657

Sandercock, J.R.  
**Fabry-Perot interferometer**—4225236

Schiff, L.N.  
**Compandor for group of FDM signals**—4221934

Spong, F.W.  
**Optical record playback apparatus employing light frequency at which alternate regions of record track exhibit anti-reflection condition**—4219848

Staebler, D.L.|Zanzucchi, P.J.  
**Method of inducing differential etch rates in glow discharge produced amorphous silicon**—4217393

Vaccaro, F.E.  
**Flat panel display device with beam collector**—4216407

VanRaalte, J.A.  
**Phosphor screen for modular flat panel display device**—4220892

Wang, C.C.|Ekstrom, L.|Wielicki, H.  
**VideoDisc lubricants**—4216970

Wu, C.T.

**Encoding analog signals into digital signals using a triangular reference—4220925**

## Picture Tube Division

Piasecinski, J.J.

**Method for assembling a base to an electron tube—4217014**

Ruth, L.C.

**Cathode ray tube display error measurement apparatus and method—4220919**

## "SelectaVision"

Allen, J.A.

**Carriage translating apparatus for videoDisc player**

**Carriage translating apparatus for VideoDisc player—4216969**

Coleman, C.F.

**VideoDisc player having modular construction—4220338**

Coleman, C.F. | Farley, N.L.

**Caddy-actuated declutching mechanism for VideoDisc player—4220339**

Torrington, L.A. | Huff, L.D.

**Constant drag carriage translating mechanism for VideoDisc player—4220340**

Torrington, L.A. | Huff, L.D.

**Mechanism for aiding carriage return in VideoDisc player—4225141**

## Solid State Division

Ahmed, A.A.

**Voltage-to-current converter apparatus—4216435**

Ahmed, A.A.

**Quasi-linear amplifier with feedback-controlled idling currents—4220930**

Ahmed, A.A.

**Non-inverting buffer circuits—4221979**

Ahmed, A.A.

**Relaxation oscillator including an SCR and having switch means for interrupting current flow therethrough—4223280**

Ahmed, A.A.

**SCR relaxation oscillator with current amplifier in its gate circuit—4223281**

Cardinal, R.E.

**Method for resistance welding of an electro-optic device housing—4217683**

Chan, K.K.

**Two into three port phase shifting power divider—4223283**

Gillberg, J.E. | Kucharewski, N.

**Drive circuit for controlling current output rise and fall times—4216393**

Giordano, R.L.

**Temperature compensated switching circuit—4220873**

Giordano, R.L.

**Temperature compensated switching circuit—4220877**

Gubitose, N.F. | Novak, R.E.  
Ronan, H.R., Jr. | Schuler, M.R.

**Meter and dispensing system for abrasive materials—4222502**

Kaplan, L.A.

**Overcurrent protection circuit for power transistor—4225897**

Leidich, A.J.

**Leakage current compensation circuit—4216394**

Nelson, H.T.

**Guide wing for a furnace paddle—4218214**

Schade, Jr., O.H.

**Relaxation oscillator not restricted by FET threshold—4219787**

Schade, Jr., O.H.

**Precision current source—4225816**

Spak, M.A.

**Etchant solution containing HF-HNO<sub>3</sub>-H<sub>2</sub>SO<sub>4</sub>-H<sub>2</sub>O<sub>2</sub> for etching Al-Ti-Cu or Ni contact metallurgy on silicon substrates—4220706**

Stewart, R.G.

**Level shift circuit—4216390**

Wheatley, Jr., C.F.

**Control circuit for multivibrator—4216442**

Wilson, R.E.

**Narrow pulse eliminator—4216388**

Wittlinger, H.A.

**Current amplifier—Re 30297**

---

# Pen and Podium

Recent RCA technical papers and presentations

---

To obtain copies of papers, check your library or contact the author or his divisional Technical Publications Administrator (listed on back cover) for a reprint.

## Advanced Technology Laboratories

O. Bessette | W. Schaming

**A Two-Dimensional Discrete Cosine Transform Video Bandwidth Compression System—NAECON 80, Dayton, Ohio, Proceedings (5/20-22/80)**

M.L. Levene | J.W. Kiebler | S.W. Fordyce

**The Fastest Fax in the West, Teleconference Symposium at the Univ. of Wisconsin, Satellite Communications (5/17 to 6/80)**

W.B. Schaming | O. Bessette

**Empirical Determination of Processing Parameters for a Real-Time 2D-DCT Video Bandwidth Compression System—SPIE**

24th Annual International Technical Symposium and Exhibit in San Diego, Calif., *Proceedings (7/31-8/1/80)*

## Americom

M.R. Freeling | W.H. Braun

**Maximum Transponder Capacity for Transmission of FDM/FM Channels, RCA Review, Vol. 41, No. 3 (9/80)**

G.S. Kaplan

**A New Technique for Transmitting Two High Quality Video Signals Over a Single Terrestrial Microwave Link—RCA Review, Vol. 41, No. 3 (9/80)**

W.T. Rowse (also L. Abbott of the Labs and G.W. Beakley of Scientific-Atlanta Inc.)

**Parameter Tradeoffs for Transmitting Two Television Channels Per Transponder, RCA Review, Vol. 41, No. 3 (9/80)**

## Astro-Electronics

H. Bilsky | R. Mancuso

**DMSP Laser Survivability Enhancement Study—4th DoD Conf. on Laser Vulnerability, Effects and Hardening, Monterey, Calif. (9/16/80)**

F. Chu | B. Wang

**Effective Dynamic Reanalysis of Large Structures—51st Shock & Vibration Symp., San Diego, Calif. (10/21/80)**

R. Gounder

**Advances in Materials Tech. for S/C Structures**—25th Anniv. Founding of the Dept. of Materials Science & Eng. (10/9/80)

C. Hubert

**Dynamics of the Generalized Dual-Spin Turn**, *RCA Review*, Vol. 41, No. 3 (9/80)

A. Schnapf

**The Tiros Era 1960-1980 and the decade ahead**—XXXI Congress, International Astronautical Federation, Tokyo, Japan (9/21/80)

W. Wilkinson (under contract to RCA)

**Antenna Pattern Data Acquisition**—Antenna Measurements Tech. Assoc. and *Proceedings* (10/4/80)

## Automated Systems

L. Arlan

**A High Performance TV Camera for Use in Target Acquisition and Laser Designator Systems**—Military Electronics Defence Exp '80, Wiesbaden, W. Germany (10/80)

L. Arlan|R.J. Wildenberger

**A Computer-Controlled Imaging System for Automatic Hybrid Inspection**, *Solid State Technology Magazine* (9/80)

M.J. Cantella|J. Klein

**Advances in Platinum Silicide Schottky-Barrier IR-CCD Image Sensors**, *SPIE*, Vol. 225, IR Image Sensor Technology (1980)

M. DeSimone

**A Finite Element, Computer-Aided, Thermal Analysis to Determine the Steady-State Temperatures in an Electronic Device**, Thesis for Bachelor of Science, MIT (6/80)

A.F. Dirsá

**Wing Automation**—EASCON '80, Arlington, Va. (9/80)

C.H. Huckins

**A Technique for Achieving Interoperability Between Data Communication Interface Standards**—International Telecommunications and Computer Exposition, Los Angeles, Calif. (11/80)

C.H. Huckins

**A Technique for Achieving Interoperability Between Data Communication Interface Standards**—Military Electronics Defence Expo '80, Wiesbaden, W. Germany (10/80)

F.F. Martin

**Chairman—Session 5, Military Applications of Electro-Optics**—Military Electronics Defence Expo '80, Wiesbaden, W. Germany (10/80)

J.P. Mergler

**Chairman, Session I, Communications A & C**—Military Electronics Defence Expo '80, Wiesbaden, W. Germany (10/80)

## Commercial Communications Systems

A.E. Jackson

**An Automatic Photoconductive Telecine Camera with Improved Film-to-Tape Transfer Features**—IEEE Broadcast Symposium, Washington Hotel, Washington, D.C. (9/18/80)

A.E. Jackson|H.G. Seer|J.F. McCoy

**An Automatic Photoconductive Telecine Camera with Improved Film-to-Tape Transfer Features**—*SMPTE* (10/7/80)

J.F. McCoy

**An Automatic Photoconductive Telecine Camera with Improved Film-to-Tape Transfer Features**—Philadelphia Section of SMPTE at RCA Camden, *SMPTE* (10-14/80)

W.S. Sepich

**A Tale of Productivity**—Applicon Users Group Meeting, Danvers, Mass. (10/6/80)

## Laboratories

L. Abbott

**Cancellation of Visible Color Crosstalk Between Two TV Signals by Use of Alternate Line Delay**—*RCA Review*, Vol. 41, No. 3 (9/80)

L. Abbott (Also W.T. Rowse of Americom and G.W. Beakley of Scientific-Atlanta Inc.)  
**Parameter Tradeoffs for Transmitting Two Television Channels Per Transponder**, *RCA Review*, Vol. 41, No. 3 (9/80)

A. Acampora|G. Saulnier

**Time Division Multiple Access of Satellite Transponders by Analog Video Signals (On a Field- or Frame-Interleaved Basis)**—*RCA Review*, Vol. 41, No. 3 (9/80)

R. Amantea

**A New Solution for Minority-Carrier Injection into the Emitter of a Bipolar Transistor**—*IEEE Transactions on Electron Devices*, Vol. ED-27, No. 7 (7/80)

D. Botez|G.J. Herskowitz

**Components for Optical Communications Systems: A Review**—*Proceedings of the IEEE*, Vol. 68, No. 6 (6/80)

E.J. Denlinger

**Losses of Microstrip Lines**—*IEEE Transactions on Microwave Theory and Techniques*, Vol. MTT-28, No. 6 (6/80)

B. Dornan|W. Slusark, Jr.|Y.S. Wu|P. Pelka  
R. Barton|H. Wolkstein|H. Huang

**A 4-GHz GaAs FET Power Amplifier: An Advanced Transmitter for Satellite Down-Link Communication Systems**—*RCA Review*, Vol. 41, No. 3 (9/80)

A.B. Dreeben|K.M. Kim (with IBM)

A. Schujko

**Measurement of Meniscus Angle in Laser Heated Float Zone Growth of Constant**

**Diameter Sapphire Crystals**—*Journal of Crystal Growth* 50 (1980)

M.T. Duffy|S. Berkman|G.W. Cullen  
R.V. D'Aiello|H.I. Moss

**Development and Evaluation of Refractory CVD Coatings as Contact Materials for Molten Silicon**—*Journal of Crystal Growth* 50 (1980)

A. Guida

**Maximizing Satellite Transponder Utilization**—*RCA Review*, Vol. 41, No. 3 (9/80)

A.C. Ipri|J.C. Sokoloski|D.W. Flatley

**Submicrometer Polysilicon Gate CMOS/SOS Technology**—*IEEE Transactions on Electron Devices*, Vol. ED-27, No. 7 (7/80)

L. Jastrzebski|P.A. Levine

A.D. Cope|W.N. Henry|D.F. Battson  
*IEEE Transactions on Electron Devices*, Vol. ED-27, No. 8 (8/80)

L.L. Jastrzebski

**The Measurement of Deep Centers in Float Zone Silicon by Photovoltage Spectroscopy**—*RCA Review*, Vol. 41 (6/80)

K. Jonnalagadda

**Syllabic Companding and Voice Capacity of a Transponder**—*RCA Review*, Vol. 41, No. 3 (9/80)

W. Kern|E. Tracy (SERI, Golden, Col.)

**Titanium Dioxide Antireflection Coating for Silicon Solar Cells by Spray Deposition**—*RCA Review*, Vol. 41 (6/80)

K.M. Kim (IBM)|S. Berkman

H.E. Temple|G.W. Cullen

**Growth and Characterization of Silicon Ribbons by the Inverted Stepanov Process Using Pyrolytic Boron Nitride Die**—*Journal of Crystal Growth* 50 (1980)

R.J. Klensch|K. Kelly

**Two-for-One Video Over Microwave Terrestrial Links**—*RCA Review*, Vol. 41, No. 3 (9/80)

W.F. Kosonocky|H.G. Erhardt|G. Meray

F.V. Shallcross|H. Elabd

**Advances in Platinum Silicide Schottky-Barrier IR-CCD Image Sensors**—*SPIE*, Vol. 225 IR Image Sensor Tech. (1980)

W.F. Kosonocky, Guest Editor

**Foreword**—*IEEE Transactions on Electron Devices*, Vol. ED-27, No. 8 (8/80)

S.G. Liu|E.C. Douglas|C.P. Wu|C.W. Magee  
S.Y. Narayan|S.T. Jolly|F. Kolondra|S. Jain  
**Ion Implantation of Sulfur and Silicon in GaAs**—*RCA Review*, Vol. 41 (6/80)

S.G. Liu|E.C. Douglas|C.W. Magee

F. Kolondra|S. Jan

**High-Energy Implantation of Silicon in GaAs**—*Appl. Phys. Lett.* 37(1) (7/1/80)

V. Mangulis

**Security of a Popular Scrambling Scheme**

for TV Pictures—*RCA Review*, Vol. 41, No. 3 (9/80)

A.R. Moore

**Photoelectromagnetic Effect in Amorphous Silicon**—*Appl. Phys. Lett.* 37(3) (8/80)

R.E. Novak (Honeywell)|R. Metz  
A. Dreeben|S. Berkman

**The Production of EFG Sapphire Ribbon for Heteroepitaxial Silicon Substrates**—*Journal of Crystal Growth* 50 (1980)

G.H. Olsen|T.J. Zamerowski|N.J. DiGiuseppe  
**1.5-1.7  $\mu\text{m}$  V.P.E InGaAsP/InP C.W. Lasers**—*Electronics Letters*, Vol. 16, No. 13 (6/19/80)

G.H. Olsen|T.Z. Zamerowski|R.T. Smith  
E.P. Bertin  
**InGaAsP Quaternary Alloys: Composition, Refractive Index and Lattice Mismatch**—*Journal of Electronic Materials*, Vol. 9, No. 6 (1980)

W. Rehwald|A. Vonlanthen|J.K. Kruger  
R. Wallerius|H.G. Unruh  
**Study of the elastic properties of  $\text{K}_2\text{SeO}_4$  at the phase transition to the incommensurate and the commensurate phase by ultrasonic techniques and Brillouin spectroscopy**—*The Institute of Physics* (1980)

W. Rehwald|A. Vonlanthen  
E. Rehaber|W. Prettl  
**The Elastic Behaviour of Ferro-elastic  $\text{Sb}_2\text{O}_7$  Polytype 2MC Studied by Ultrasonic Experiments and Brillouin Scattering**—*Condensed Matter* (1980)

P.M. Russo  
**VLSI Impact on Microprocessor Evolution, Usage, and System Design**—*IEEE Transactions on Electron Devices*, Vol. ED-27, No. 8 (8/80)

L. Schiff  
**Capacity of Fixed-Assigned Versus Demand-Assigned Single-Channel-Per-Carrier Systems with Power-Limited Transponders**—*RCA Review*, Vol. 41, No. 3 (9/80)

H. Staras  
**Foreword to Special Issue on Satellite Communications**—*RCA Review*, Vol. 41, No. 3 (9/80)

M. Toda|S. Osaka|S. Tosima  
**Large Area Display Element Using PVF<sub>2</sub> Bimorph with Double-Support Structure**—*Ferroelectrics*, Vol. 23 (1980)

L.C. Upadhyayula  
**GaAs MESFET Comparators for Gigabit-**

**Rate Analog-to-Digital Converters**—*RCA Review*, Vol. 41 (6/80)

## Missile and Surface Radar

K. Abend

**Spectral Estimation for Radar Imaging of Aircraft**—U.S. DoD Tri-Service NCTR Tech. Conference, Air Force Academy, Colorado Springs, Col. (9/80)

W. Bernard

**Combat System Support Services**—American Society of Naval Engineers, Cherry Hill, N.J. (10/80)

F.J. Buckley

**Software Quality Assurance Management**—Software Quality Assurance Seminar, University of Portland, Ore. (10/80)

R.I. Creedon, Guest Lecturer on  
**Support Systems—Electrical, Support Systems—Mechanical, and Room Arrangements**—Summer Course: Combat Systems Engineering and Ship Design, MIT, Cambridge, Mass. (8/80)

J.W. Douglas

**Interactive Placement on the Applicon System**—Applicon Users Group Technical Meeting (Printed Wiring Board Special Interest Group), Danvers, Mass. (1980)

J.W. Douglas

**Extra Memory for Programming on the Applicon System**—Applicon Users Group Technical Meeting (Software Special Interest Group), Danvers, Mass. (10/80)

L. Finkel|D.M. Greeley|F.P. Papasso  
**Role of Phased Array Radars in the Future TACS in the 1990 Era**—EASCON '80, Arlington, Va. (9/80)

I.E. Goldstein

**Coordinator and Lecturer: Introduction—Topside Design—Other**—Summer Course: Combat Systems Engineering and Ship Design, MIT, Cambridge, Mass. (8/80)

L.J. Grantner, Guest Lecturer

**Anti-Submarine Warfare: Detect, Control, Engage; Anti-Submarine Warfare: Ship Impacts**—Summer Course: Combat Systems Engineering and Ship Design, MIT, Cambridge, Mass. (8/80)

W.C. Grubb, Jr.

**Electro-Optics for Non-Electrical Engineers**—Training Program, U.S. Navy Station, Patuxent River, Md. (9/80)

R.F. Kolc

**Computerized Thick Film Printer**—IEEE

*Transactions on Components, Hybrids, and Manufacturing Technology*, Vol. CHMT-3, No. 3 (9/80)

W.T. Patton

**Radar Antenna Technology**—Fourth Annual Antenna Applications Symposium, Univ. of Illinois (9/80)

W.T. Patton

**Low Sidelobe Phased Array Antennas for Tactical Radar**—Phased Array Workshop at NRL, Washington, D.C. (9/80)

M.H. Plofker, Guest Lecturer

**Combat System Availability**—Summer Course: Combat Systems Engineering and Ship Design, MIT, Cambridge, Mass. (8/80)

R.J. Renfrow, Guest Lecturer

**Topside Design-Radar and Topside Design-Weapons**—Summer Course: Combat Systems Engineering and Ship Design, MIT, Cambridge, Mass. (8/80)

E.E. Roberts, Jr., Guest Lecturer

**Error Budgeting and Alignment, and Ships' Flexure**—Summer Course: Combat Systems Engineering and Ship Design, MIT, Cambridge, Mass. (8/80)

R.L. Schelhorn

**Fabrication of Thick-Film Circuits on Co-fired Ceramic Substrates**—*Solid State Technology*, (10/80)

J.T. Threston, Guest Lecturer

**System Functional Analysis and Functional Allocation, Performance Tradeoffs Analysis, Anti-Air Warfare-Detect/Control/Engage, Contemporary Combat System Designs, and Tactical Computer Programs**—Summer Course: Combat Systems Engineering and Ship Design, MIT, Cambridge, Mass. (8/80)

A. Wainwright, Jr.

**Using BASIC for Printing Wiring Board Production**—Applicon Users Group Technical Meeting (Printed Wiring Board Special Interest Group), Danvers, Mass. (10/80)

A. Wainwright, Jr.

**Using BASIC on an Applicon System**—Applicon Users Group Technical Meeting (Software Special Interest Group), Danvers, Mass. (10/80)

## Solid State Division

D.L. Patterson

**The Production of EFG Sapphire Ribbon for Heteroepitaxial Silicon Substrates**—*Journal of Crystal Growth* 50 (1980)

# Engineering News and Highlights

## Staff Announcements

## Consumer Electronics

**Loren E. Wolter**, President and General Manager, RCA Taiwan, Limited, announces the appointment of **John A. Gross** as Manager, Manufacturing-Taoyuan.

**David R. Crawford**, General Manager, RCA Componentes-S.A. deC.V., announces the appointment of **James R. Arvin** as Manager, Manufacturing-Engineering.

**J.B. Thomas**, Manager, Manufacturing Engineering, announces the appointment of **Merred A. Blair** as Manager, Process Engineering.

## Government Systems

**John D. Rittenhouse**, Division Vice-President and General Manager, announces the appointment of **James P. Feller** as Division Vice-President, Engineering.

## Laboratories

**William M. Webster**, Vice-President, RCA Laboratories, announces the appointment of **Brown F. Williams** as Staff Vice-President, Display and Energy Systems Research.

**Bernard J. Lechner**, Director, Video Systems Research Laboratory, announces the organization of the Video Systems Research Laboratory as follows: **Frank J. Marlowe**, Head, Digital Video Research; **Charles B. Oakley**, Head, Broadcast Systems Research; **Robert E. Flory**, Fellow, Technical Staff; **J. Guy Woodward**, Fellow, Technical Staff; **Leonard Schiff**, Head, Communication Analysis Research; **Paul Schnitzler**, Head, Transmission Technology Research; and **Harold Staras**, Staff Scientist, Satellite Programs.

**Alfred H. Teger**, Director, Advanced Systems Research Laboratory, announces the organization of the Advanced Systems Research Laboratory as follows: **Allen J. Korenjak**, Head, Automation Systems Research; **Thomas M. Stiller**, Fellow, Technical Staff; **Emilie M. Lengel**, Head,

Data Communications Research; **Eduard Luedicke**, Fellow, Technical Staff; **D. Alex Ross**, Staff Engineer; **Richard H. Roth**, Head, System Architecture Research; **Allen H. Simon**, Fellow, Technical Staff; **Alfred H. Teger**, Acting, Microsystems Research; and **Charles M. Wine**, Fellow, Technical Staff.

## Solid State Division

**Larry J. French**, Division Vice-President, Solid State Technology Center, announces the organization of the Solid State Technology Center as follows: **Philip K. Baltzer**, Head, LSI Systems and Applications; **David S. Jacobson**, Manager, Custom LSI Products; **Israel H. Kalish**, Manager, Integrated Circuit Design and Process Development; **Walter F. Lawrence**, Manager, Photomask Technology and Operations; **Lawrence M. Rosenberg**, Manager, Design Automation; **William C. Schneider**, Manager, Special Projects and

Products; and **Louis S. Napoli**, Staff Scientist, Galileo Program.

**Nicholas Kucharewski**, Manager, Design Engineering, Large Scale Integration, announces the organization of Design Engineering—Large Scale Integration as follows: **Richard P. Fillmore**, Manager, West Coast Design Center; **James E. Gillberg**, Leader Technical Staff, Timekeeping and Custom Design; **Mark D. Holbrook**, Leader Technical Staff, Memory Design; **Al A. Kay**, Manager, Product Engineering; **Henry S. Miller**, Manager, Design Automation; **George I. Morton**, Project Manager, Bulk CMOS Technology; and **Joel R. Oberman**, Leader Technical Staff, Microprocessor Design.

**Henry Kressel**, Staff Vice-President, Solid State Research, announces the organization of Solid State Research as follows: **Philip K. Baltzer**, Head, LSI Systems and Applications; **Bernard Hershenov**, Director, Solid State Devices Laboratory; **Louis S. Napoli**, Staff Scientist; and **David E. O'Connor**, Director, Integrated Circuit Technology Research Laboratory.

## French Named Division Vice-President



**Dr. Larry J. French** is newly named Division Vice-President, Solid State Technology Center, reporting to **Dr. Robert S. Pepper**, Vice-President and General Manager, RCA Solid State Division.

In his new position, Dr. French is responsible for research and development in IC design, semiconductor technology, systems, photomask technology and

computer-aided design activities for the Solid State Division and other major operating units such as the Government Systems Division, "SelectaVision" VideoDisc Operations, Consumer Electronics and Broadcast Systems.

In announcing the appointment, Dr. Pepper indicated that the Technology Center, previously a part of RCA's David Sarnoff Research Center, will now be aligned with the Solid State Division to enhance the Division's efforts to maintain a competitive state-of-the-art position in semiconductor markets and to support the specialized semiconductor needs of other RCA major operating units.

Dr. French joined the RCA Laboratories in 1962 as a member of the technical staff, involved in research on interactive graphic systems, computer-aided design, and MOS design and process technology for logic circuits and memories. In 1972 he became manager of design automation for the Solid State Technology Center's design automation activity, and four years later was named Director of LSI Systems and Design and Photomask Technology. This latter position encompassed responsibilities for both the Technology Center and Solid State Division.

# Editorial Representatives

Contact your Editorial Representative, at the extensions listed here, to schedule technical papers and announce your professional activities.

\* Technical Publications Administrators, responsible for review and approval of papers and presentations, are indicated here with asterisks before their names.

## Americom

\* Murray Rosenthal Princeton, New Jersey Ext. 4192

## Commercial Communications Systems Division (CCSD)

### Broadcast Systems

\* Bill Sepich Camden, New Jersey Ext. 2156  
Krishna Praba Gibbsboro, New Jersey Ext. 3605  
Andrew Billie Meadowlands, Pennsylvania Ext. 6231

### Mobile Communications Systems

\* Paul Buess Meadowlands, Pennsylvania Ext. 6439  
or 6229

### Avionics Systems

\* Stewart Metchette Van Nuys, California Ext. 3806

### Cablevision Systems

\* John Ovnick Van Nuys, California Ext. 3011

## Consumer Electronics (CE)

\* Clyde Hoyt Indianapolis, Indiana Ext. 5208  
Francis Holt Indianapolis, Indiana Ext. 5217  
Chuck Limberg Indianapolis, Indiana Ext. 5117  
Don Willis Indianapolis, Indiana Ext. 5883

## Distributor and Special Products Division (DSPD)

\* Charles Rearick Deptford, New Jersey Ext. 2299

## Globcom

\* Walt Leis New York, New York Ext. 7711

## Government Systems Division (GSD)

### Astro-Electronics

\* Ed Goldberg Princeton, New Jersey Ext. 2544

### Automated Systems

\* Ken Palm Burlington, Massachusetts Ext. 3797  
Gene Gallagher Burlington, Massachusetts Ext. 2975

### Government Communications Systems

\* Dan Tannenbaum Camden, New Jersey Ext. 3081  
Harry Ketcham Camden, New Jersey Ext. 3913

### Government Engineering

\* Merle Pietz Camden, New Jersey Ext. 2161

### GSD Staff

\* Ed Moore Cherry Hill, New Jersey Ext. 5833

### Missile and Surface Radar

\* Don Higgs Moorestown, New Jersey Ext. 2836  
Jack Friedman Moorestown, New Jersey Ext. 2112

## National Broadcasting Company (NBC)

\* Bob Mausler New York, New York Ext. 4385

## Patent Operations

Joseph Tripoli Princeton, New Jersey Ext. 2992

## Picker Corporation

Allen E. Mushin Northford, Connecticut (203) 484-2711  
L.J. Theriault Cleveland, Ohio (216) 449-3000

## Picture Tube Division (PTD)

\* Ed Madendorf Lancaster, Pennsylvania Ext. 3657  
Nick Meena Circleville, Ohio Ext. 1228  
Jack Nubani Scranton, Pennsylvania Ext. 1499  
J.R. Reece Marion, Indiana Ext. 5566

## RCA Limited (Canada)

Bob McIntyre Ste Anne de Bellevue (514) 457-9000

## RCA Records

\* Dave Devarajan\* Indianapolis, Indiana Ext. 6109

## RCA Service Company

\* Joe Steoger Cherry Hill, New Jersey Ext. 5547  
Ray MacWilliams Cherry Hill, New Jersey Ext. 5986  
Dick Dombrosky Cherry Hill, New Jersey Ext. 4414

## Research and Engineering

### Corporate Engineering

\* Hans Jenny Cherry Hill, New Jersey Ext. 4251

### Laboratories

Maucie Miller Princeton, New Jersey Ext. 2322

## "SelectaVision" VideoDisc Operations

\* Woody Workman Indianapolis, Indiana Ext. 3235

## Solid State Division (SSD)

\* John Schoen Somerville, New Jersey Ext. 6467

### Power Devices

Harold Ronan Mountaintop, Pennsylvania Ext. 1633  
or 1827  
John Cadra Somerville, New Jersey Ext. 6909

### Integrated Circuits

Dick Morey Palm Beach Gardens, Florida Ext. 1262  
Sy Silverstein Somerville, New Jersey Ext. 6168  
John Young Findlay, Ohio Ext. 1307

### Electro-Optics and Devices

John Grosh Lancaster, Pennsylvania Ext. 2077

### Solid State Technology Center

Judy Yeast Somerville, New Jersey Ext. 7357

# **RCA** Engineer

A technical journal published by  
Corporate Research and Engineering  
"by and for the RCA<sup>®</sup> engineer"

Printed in the U.S.A. Form No. RE-26-3